

Fitting Instructions



SKU

TSF750

PRODUCT

TAG Rear Step for Ford Transit Custom (03/2013 - 03/2021)

SPECIFICATIONS

- Towbar Class: Rear Step
- Approx. Fitment Time: 30 Minutes

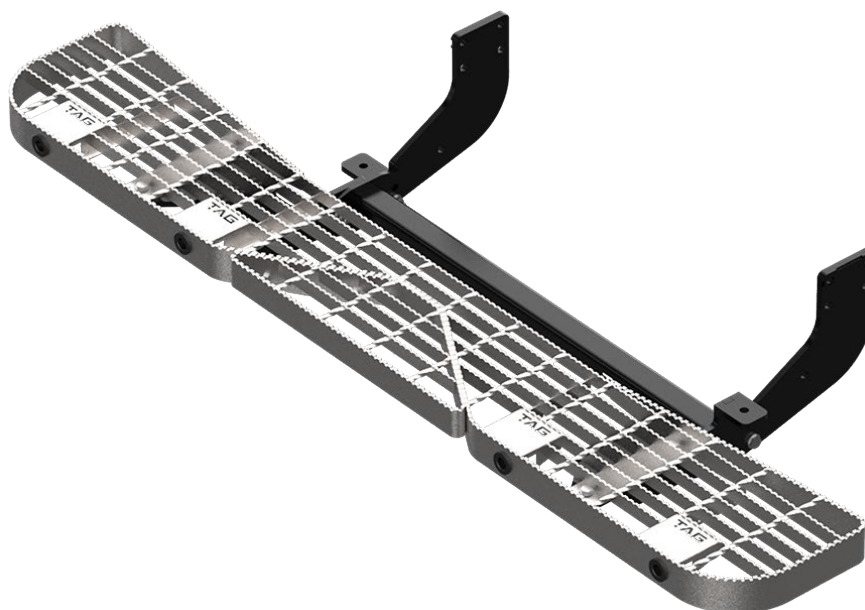

Scan for latest version of these instructions

TOOLS REQUIRED

- Spanners
- Sockets
- Air Saw or similar.
- Trim Removal Tool
- Torque Wrench

IN THIS GUIDE

- Fitment Instructions
- Torque Settings
- Warranty Info

Towbar Assembly

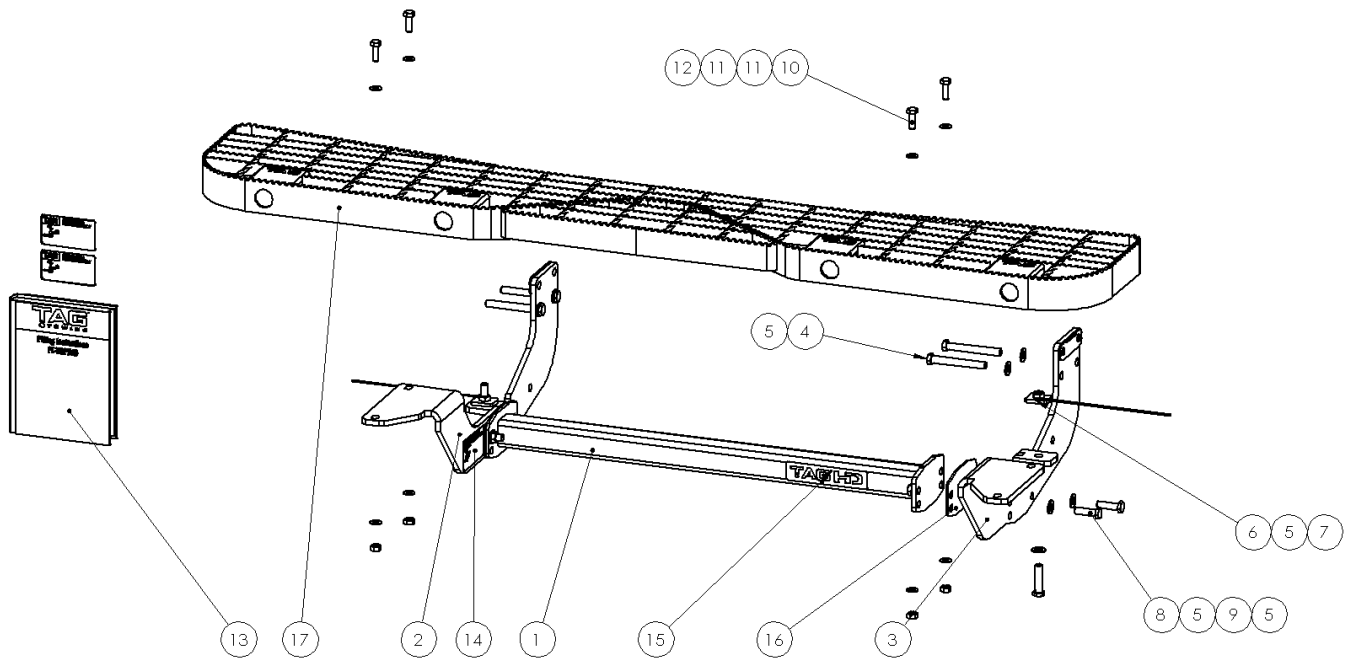

ITEM NO.	DESCRIPTION	QTY	ITEM NO.	DESCRIPTION	QTY
1	Welded Cross Member Assembly	1	10	M10 x 30 x 1.25 Bolt	4
2	End Plate Assembly PS	1	11	M10 Flat Washer	8
3	End Plate Assembly DS	1	12	M10 x 1.25 Nut	4
4	M12 x 1.75 x 100 Bolt	4	13	Fitting Instruction	1
5	M12 Flat Washer	14	14	TAG Compliance Sticker	3
6	M12 x 1.25 Nut Plate on 250mm Wire	2	15	TAG HD Sticker 150 x 33mm	1
7	M12 x 1.25 x 50 Bolt	2	16	End Cap Spacer	2
8	M12 x 1.25 x 40 Bolt	4	17	TAG Rear Step	1
9	M12x1.25 Nut	4			

Important Information



Warning:

- This product is for towing purposes only and must only be loaded as shown in your vehicle Owner's Manual.
- This towbar is NOT to be drilled, cut, welded, or modified in any way.
- Check behind chassis rail and body panels before drilling to ensure no hazards are present.
- All load ratings shown are under the assumption your trailer has a functional braking system installed.
- When installed in positions other than the one depicted in these instructions the Tow Ball Mount may interfere or obstruct certain features of your vehicle (tailgate opening, Chassis clearance, etc.)

General:

- Before fitting this towbar read fitting instructions and check installation hardware is correct.
- Check that the towbar is suitable for the vehicle and be wary of any changes to the vehicle design that may conflict with the fitting of this towbar. (Tray, Canopy, Suspension etc.)
- After drilling, blow any filings clear, remove any burrs and treat exposed metal with a rust inhibitor.
- The high tensile fasteners supplied with this product are an integral feature to achieving the specified rating, if replacement is required ensure that fasteners of the same grade (8.8) & quality are used. Contact an authorised TAG distributor or the TAG fitment center - (07) 3208 3022 - if further information is required.

Towbar Maintenance and Care:

It is recommended, when not in use, the Tow Ball Mount assembly and class 4 Pin and Clip is stored inside the car away from moisture to prevent standing water from forming rust. Inspect to ensure, on regular basis, fasteners are torqued to the specifications below and in good condition.

Ensure that the fitting instructions are read and understood prior to fitment, Following the fitment place these instructions in the vehicle's glovebox after installation is completed.

Metric Bolt Torque Settings

Diameter	Pitch	Grade	Torque	Unit		Diameter	Pitch	Grade	Torque	Unit
M8	1.25	8.8	29	Nm		M12	1.25	10.9	125	Nm
M10	1.25	8.8	57	Nm		M12	1.50	10.9	105	Nm
M10	1.50	8.8	44	Nm		M14	1.25	10.9	195	Nm
M12	1.25	8.8	101	Nm		M14	1.50	10.9	165	Nm
M12	1.50	8.8	97	Nm		M16	1.25	10.9	295	Nm
M12	1.75	8.8	77	Nm		M16	1.50	10.9	250	Nm
M14	2.00	8.8	122	Nm		50mm Tow Ball	N/A	N/A	300	Nm
M16	2.00	8.8	190	Nm		70mm Tow Ball	N/A	N/A	750	Nm

Step 1: Fit Bar & Step

Note to installer: Fitting of this step will inhibit the correct function of the reverse sensors. It is recommended that the provided RSM Kit be used to relocate the OEM reverse sensors onto the step & wiring extended.

- a. Remove 2x M12 bolts from each chassis & discard.
- b. Lift PS endplate to the chassis & insert 2x M12x 100 bolts & flat washers into lower holes where original bolts were removed. Insert 2x M12x 100 bolts with washers into top holes & add flat washers & nuts to the outside. Leave loose.
- c. Insert nut plate on wire into lower chassis rail and loosely fasten with M12x 50 bolts & washers.
- d. Repeat on DS.
- e. Lift welded main bar up to end plates and insert 4x M12x 40 bolts with washers & nuts. Leave loose.
- f. If there is more than approx. 3mm clearance between the parts on each side, then spacers will be required.
- g. If the clearance is less than this, spacers will not be required between the parts.
- h. Mount the step onto the bracket /step assemblies and insert 4x M10x 30 bolts with flat washers & nuts. Leave loose.
- i. Fasten the M12 chassis bolts followed by the cross-member bolts to the torque specification on page 3.
- j. Align the step with the bumper and fasten the M10 step bolts.



Step 2: Complete Towbar & Apply Spare Compliance Label

- a. Apply one of the compliance labels to the pillar of the driver's door. Leave the remaining label and the fitting instructions in the vehicle handbook.



TAG Warranty Statement



SWD warrants your TAG Towbar for its full product life under the following conditions:

- You can show proof of purchase.
- The towbar has been correctly installed by a suitably qualified installer.
- The towbar has not been modified or abused in any way and has only been used for the purpose intended.
- The towbar was not fitted second hand to your vehicle.

The extent of this warranty includes materials and workmanship used in the manufacture of the towbar and is to the equivalent value of current, full replacement cost.

Nothing stated or implied in this warranty limits in any way, the statutory rights that you may have.

To make a claim visit the original installer in the first instance or, if you are unable to or are not satisfied with their help, then contact us direct by phone on 1300 669122 or visit www.swd.com.au.