

# Fitting Instructions



SKU

**T4H769**

PRODUCT

**TAG Heavy Duty Towbar for Isuzu NLR 200 SWB (01/2013 - on)**

SPECIFICATIONS

- Towbar Class: CL 4 Heavy Duty
- Towing Capacity: 4000kg
- Tow ball Weight: 400kg
- Approx. Fitment Time: 90 Minutes



Scan for latest version of these instructions

TOOLS REQUIRED

- Spanners
- Sockets
- Air Saw or similar.
- Trim Removal Tool
- Torque Wrench

IN THIS GUIDE

- Fitment Instructions
- Torque Settings
- Warranty Info

# Towbar Assembly

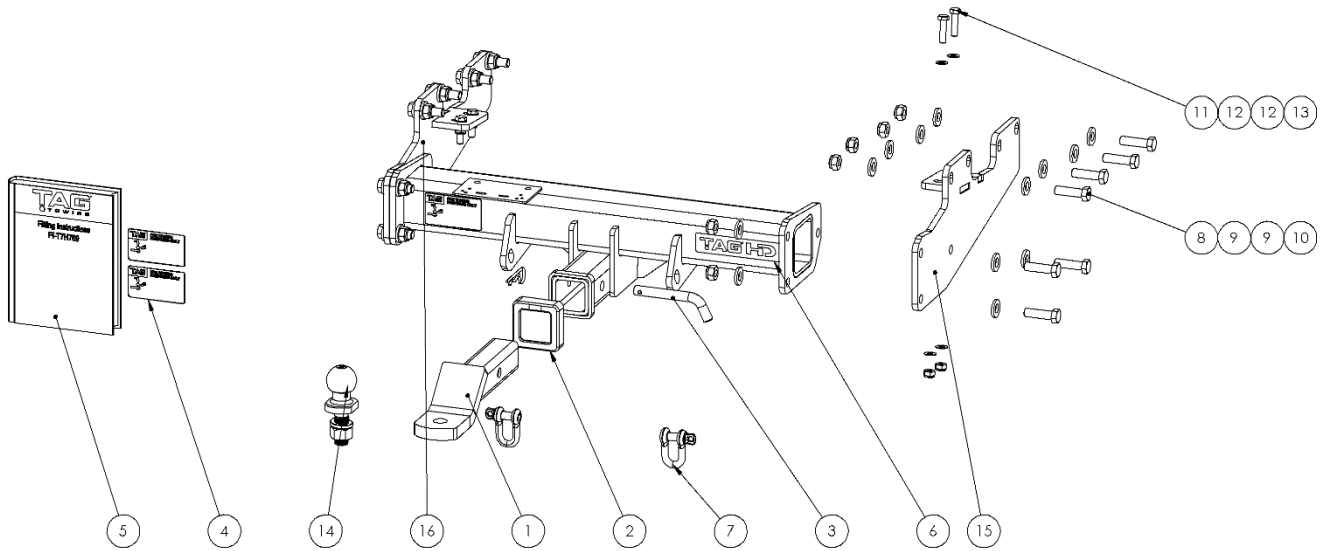

Item No.	Description	QTY.	Item No.	Description	QTY.
1	L4045 TBM	1	10	M14 X 1.5 Pitch Nyloc Nut	14
2	TAG Hitch Cover	1	11	M10 X 40 X 1.25 Bolt	4
3	Class 4 Pin & Clip	1	12	M10 Flat Washer	8
4	TAG Compliance Sticker	3	13	M10 x 1.25 Nyloc Nut	4
5	Fitting Instruction	1	14	50mm TAG Tow Ball with Flat edge - Chrome	1
6	TAG HD Sticker 150 x 33mm	1	15	End Plate Assembly DS	1
7	D-Shackle - 13mm Thick, 2000kg	2	16	End Plate Assembly	1
8	M14 x 1.5 x 50 Hex Set Screw	14	17	Welded Main Bar Assembly for T7H677	1
9	M14 Flat Washer	28			

# Important Information



## Warning:

- This product is for towing purposes only and must only be loaded as shown in your vehicle Owner's Manual.
- This towbar is NOT to be drilled, cut, welded, or modified in any way.
- Check behind chassis rail and body panels before drilling to ensure no hazards are present.
- All load ratings shown are under the assumption your trailer has a functional braking system installed.
- When installed in positions other than the one depicted in these instructions the Tow Ball Mount may interfere or obstruct certain features of your vehicle (tailgate opening, Chassis clearance, etc.)

## General:

- Before fitting this towbar read fitting instructions and check installation hardware is correct.
- Check that the towbar is suitable for the vehicle and be wary of any changes to the vehicle design that may conflict with the fitting of this towbar. (Tray, Canopy, Suspension etc.)
- After drilling, blow any filings clear, remove any burrs and treat exposed metal with a rust inhibitor.
- The high tensile fasteners supplied with this product are an integral feature to achieving the specified rating, if replacement is required ensure that fasteners of the same grade (8.8) & quality are used. Contact an authorised TAG distributor or the TAG fitment center - (07) 3208 3022 - if further information is required.

## Towbar Maintenance and Care:

It is recommended, when not in use, that the Tow Ball Mount assembly and class 4 Pin and Clip is stored inside the car away from moisture to prevent standing water from forming rust. Inspect to ensure, on regular basis, fasteners are torqued to the specifications below and in good condition.

Ensure that the fitting instructions are read and understood prior to fitment, Following the fitment place these instructions in the vehicle's glovebox after installation is completed.

*Metric Bolt Torque Settings*

Diameter	Pitch	Grade	Torque	Unit		Diameter	Pitch	Grade	Torque	Unit
M8	1.25	8.8	29	Nm		M12	1.25	10.9	125	Nm
M10	1.25	8.8	57	Nm		M12	1.50	10.9	105	Nm
M10	1.50	8.8	44	Nm		M14	1.25	10.9	195	Nm
M12	1.25	8.8	101	Nm		M14	1.50	10.9	165	Nm
M12	1.50	8.8	97	Nm		M16	1.25	10.9	295	Nm
M12	1.75	8.8	77	Nm		M16	1.50	10.9	250	Nm
M14	2.00	8.8	122	Nm		50mm Tow Ball	N/A	N/A	300	Nm
M16	2.00	8.8	190	Nm		70mm Tow Ball	N/A	N/A	750	Nm

## Step 1: Fit Towbar

- Align the holes in the chassis endplates with the holes in the chassis.
- Insert M14 x 1.5 x 50 bolts with flat washers into holes of the endplate and chassis. Fasten loosely with M14 Nyloc nuts with flat washers.
- Insert M10 x 1.25 x 50 bolts with flat washers into vertical holes of end plates & chassis rails. Fasten loosely with M10 x 1.25 nyloc nuts with flat washers.
- Lift main bar assembly up to end plates and loosely secure with 3 x M14 x 1.5 x 50 set screws with flat washers per side. Secure loosely with remaining M14 nyloc nuts and flat washers.
- Beginning at the chassis, tighten all bolts to the torque specification (Pg3).

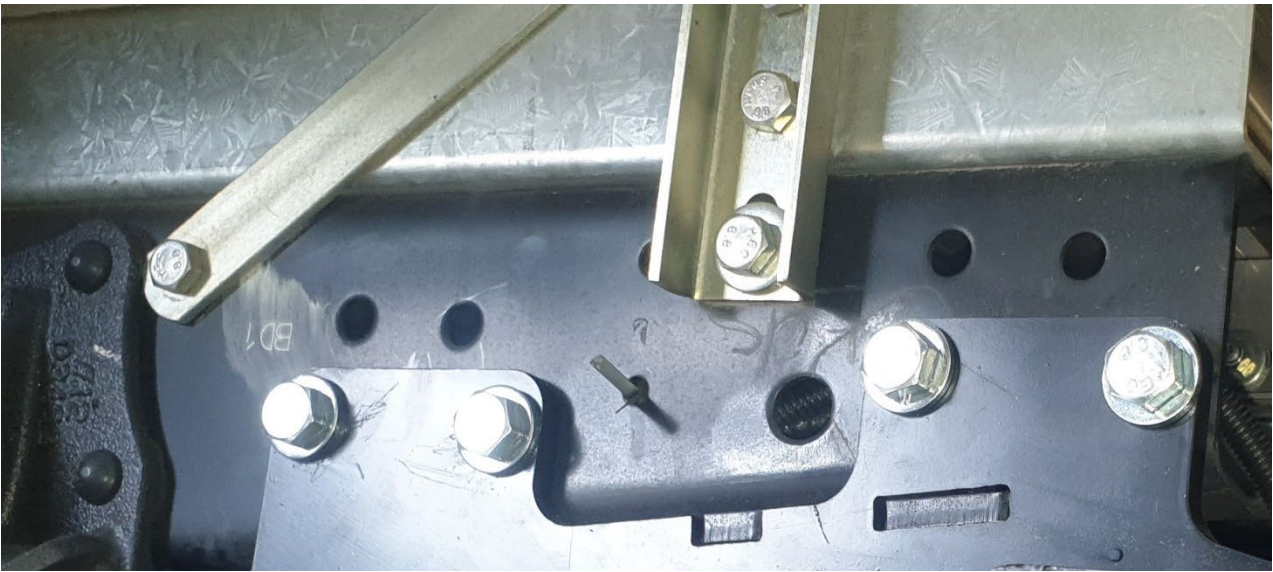

# Installation Instructions



---

## Step 4: Complete Towbar & Apply Spare Compliance Label

---

- a. Attach TAG Hitch cover with rubber mallet carefully to prevent breaking.
- b. Attach Tow ball to Ball Mount and slide into receiver. Secure with Pull pin and Clip if you are going to tow straight away. Alternatively, secure the Ball Mount in a safe place inside your vehicle.
- c. Apply one of the compliance labels to the pillar of the driver's door. Leave the remaining label and the fitting instructions in the vehicle handbook.



# TAG Warranty Statement



SWD warrants your TAG Towbar for its full product life under the following conditions:

- You can show proof of purchase.
- The towbar has been correctly installed by a suitably qualified installer.
- The towbar has not been modified or abused in any way and has only been used for the purpose intended.
- The towbar was not fitted second hand to your vehicle.

The extent of this warranty includes materials and workmanship used in the manufacture of the towbar and is to the equivalent value of current, full replacement cost.

Nothing stated or implied in this warranty limits in any way, the statutory rights that you may have.

To make a claim visit the original installer in the first instance or, if you are unable to or are not satisfied with their help, then contact us direct by phone on 1300 669122 or visit [www.swd.com.au](http://www.swd.com.au).