

# TUB SHOE DRAIN

Cat. No.  
5599TS



## Features:

- ▶ Twist-and -Lift Stopper
- ▶ For use with tubs without overflow
- ▶ Rubber gasket included
- ▶ Available in 5 Finishes

## Finishes:

- CP** Polished Chrome
- BP** Polished Brass
- SN** Brushed Nickel
- PN** Polished Nickel
- ORB** Oil Rubbed Bronze

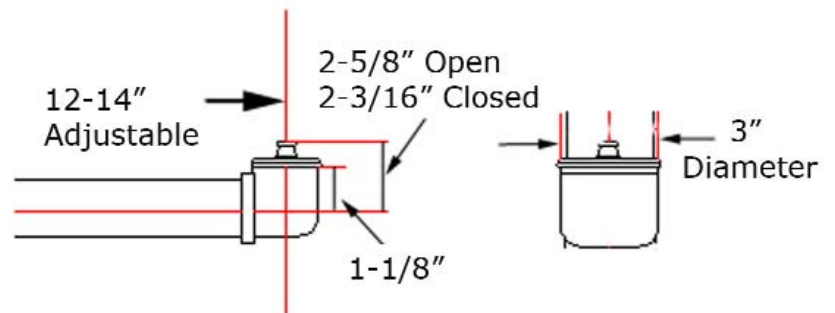

Dimensions and specifications subject to change without notice.