



Model # 3411

INSTRUCTIONS

1. Drill two holes 1-1/8" as per your determined measurements.

2. Screw the floor flange escutcheons up on bottom of each riser tube. Make sure to screw the flange all the way to the top. If the distance to the faucet connection is greater then the flange can be adjusted.

3. Lower riser tubes through floor (make sure you have valve handles positioned as you would like them). First position the supply lines as desired and use the screw to secure the floor flange to the floor. Install lock nut nuts (leave loose and attach faucet). Then tighten the faucet connections and lock nuts, securing riser tubes in place.

4a. If you are using plastic water lines a 3/4" FIP X barb adapter will attach directly to the 3/4" running thread on riser tube.

4b. If you are using copper pipe - you will have to use the 3/4" & 1/2" brass reducers and 3/4" fibre washers (make sure you soak the washers in water before using). Put washer between riser tube and reducer and tighten using Allen wrench. Attach to your copper line.

5. Pressure test riser tubes before closing access plate.

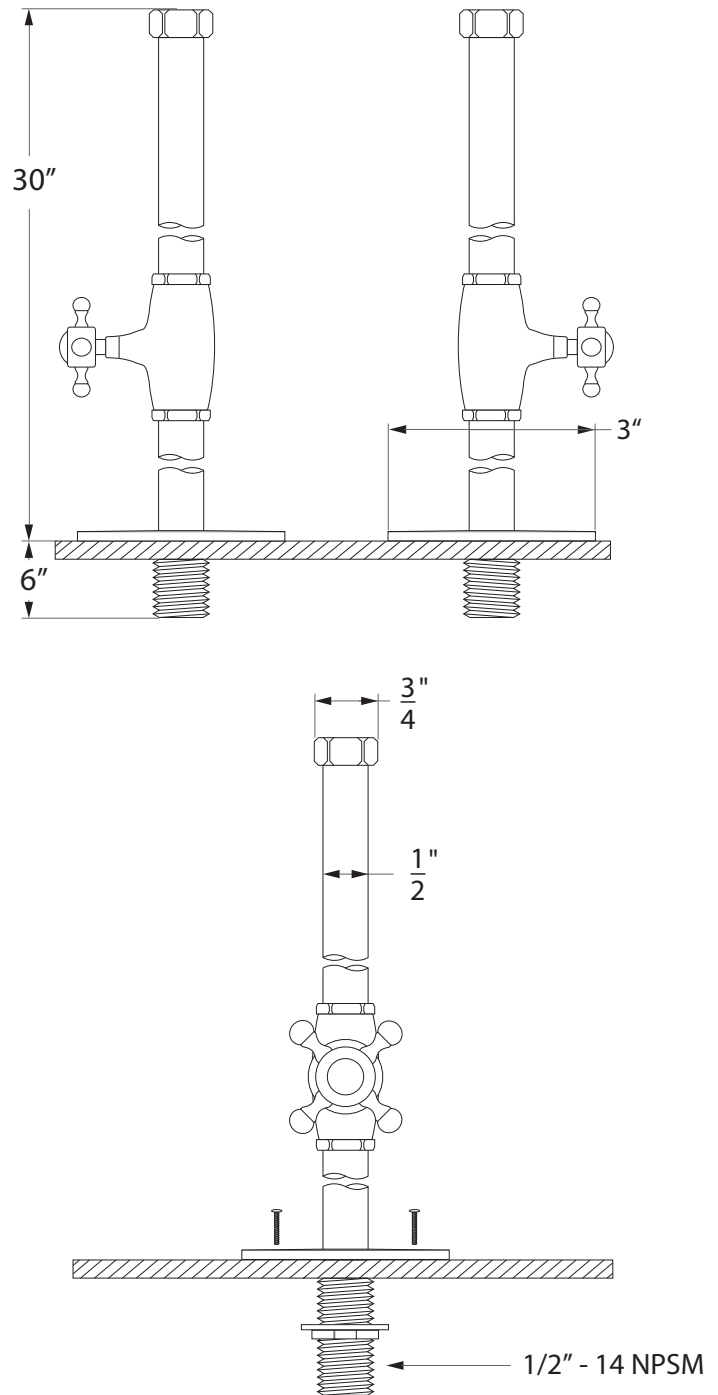

NOTE

Before drilling holes in floor, determine the width of the faucet supply nuts that you want to attach the riser tubes to (these will be for how far apart you will be drilling holes). Now determine where your tub lip will be to make sure faucet spout is at least 1" inside of tub lip.

CARE AND MAINTENANCE

Minimum Maintenance is required to maintain product finish. With proper maintenance your CHEVIOT Faucet will continually look like new. Special care should be taken when cleaning your faucet and the following suggestions should help extend your faucet life.

- Cleaning should be done regularly using a soft cotton cloth and warm water, then towel dry.
- Do not use cleaners that contain abrasives or harsh chemicals; Care should be taken in selecting cleaning supplies. Many cleaners contain detergents, ammonia, or other corrosive solvents that could damage your faucet finish.
- occasionally clean with a non-abrasive wax polish.