

FEATURES:

- All brass construction
- 3/8" brass rod can be cut to any length
- Compression fitting for easy installation
- Available in all Sigma finishes
- Mounting hardware is not supplied
- Meets ASME A112.18.1-2005 / CSAB 125-1-2005

Specifications
Shower Accessory

Ceiling or Wall Bracket
1/2" Shower Arm
18.10.150

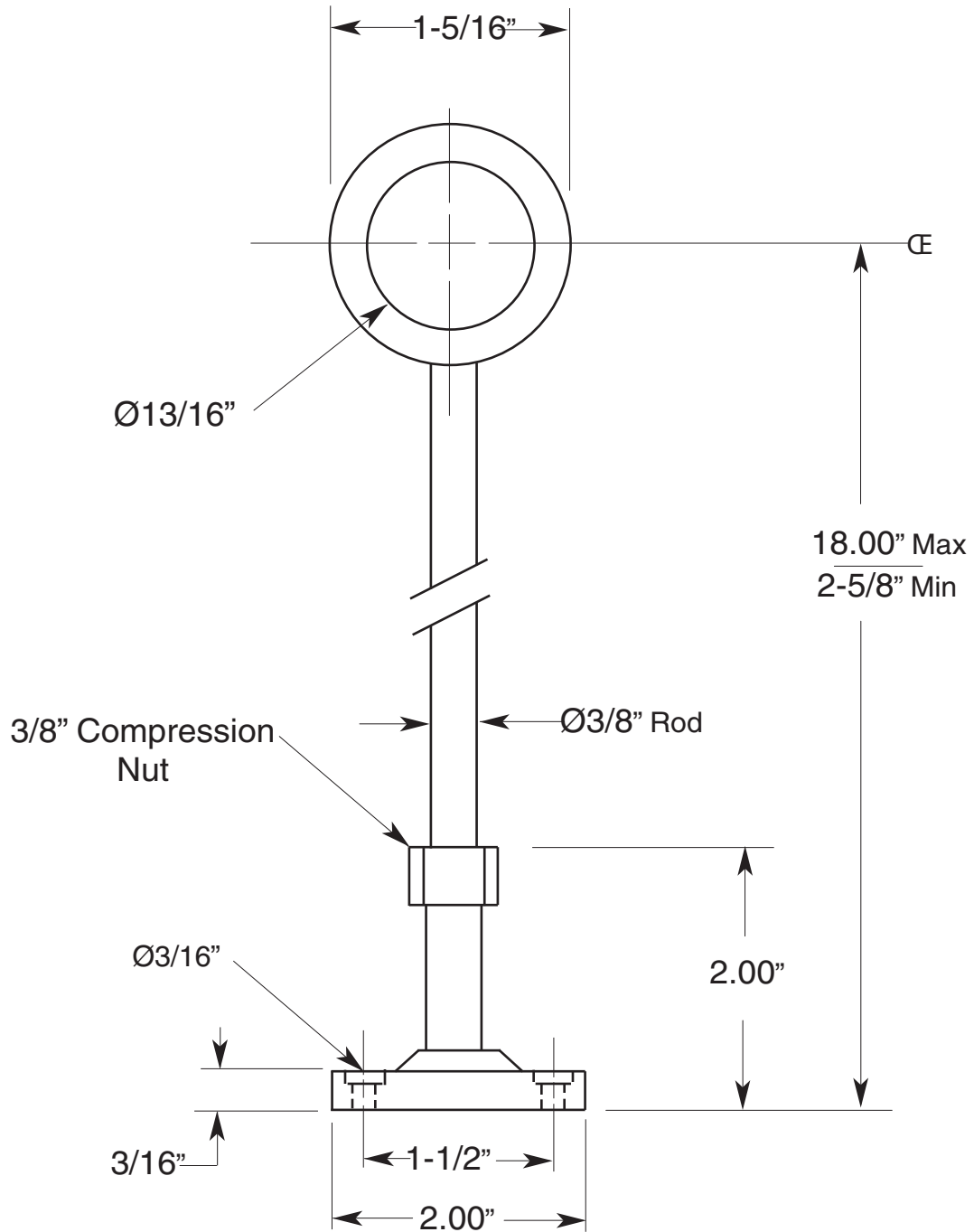

Note: Measurements are subject to change or cancellation. No responsibility is assumed for use of superseded or voided pages.