

ACRYLIC ROLL TOP TUB

Cat. No.
ATR60

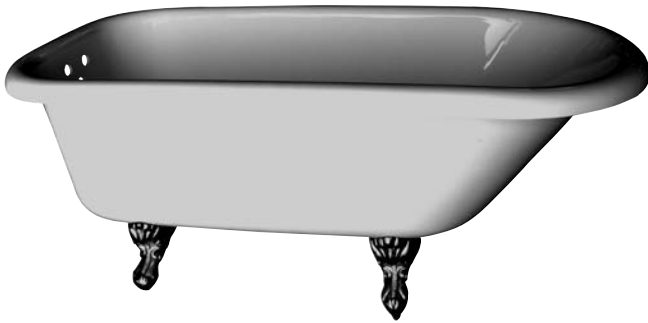

L: 60 1/2"
W: 29 1/2"
H: 24 1/2" (from floor)
17 3/4" (from bottom of tub)

Top of tub to center of faucet holes: 3 1/4"

The following is recommended for ATR60 tubs:

- Tub wall-mounted faucets
- Double offset bath supplies: part #5576
- Leg tub drain: part #5599

Do Not Use with rigid, freestanding supplies.

Gallon Capacity: 40
Shipping Weight: 110 lbs.
Empty Weight: 56 lbs.
Filled Weight: 410 lbs.

All ATR60 tubs have 3 3/8" centers in tub wall.

Features:

- ▶ Inside finish is either white or bisque to match outside color
- ▶ Ball and Claw Feet available in 8 finishes
- ▶ Outside is textured fiberglass reinforced polyester coated with two-part epoxy
- ▶ Feet are attached and leveled before shipment
- ▶ Tub is thoroughly inspected before shipment

Tub Colors

WH White
BQ Bisque

Foot Finishes

BP Polished Brass	PN Polished Nickel
CP Polished Chrome	BQ Bisque
BN Brushed Nickel	BL Black
ORB Oil Rubbed Bronze	WH White

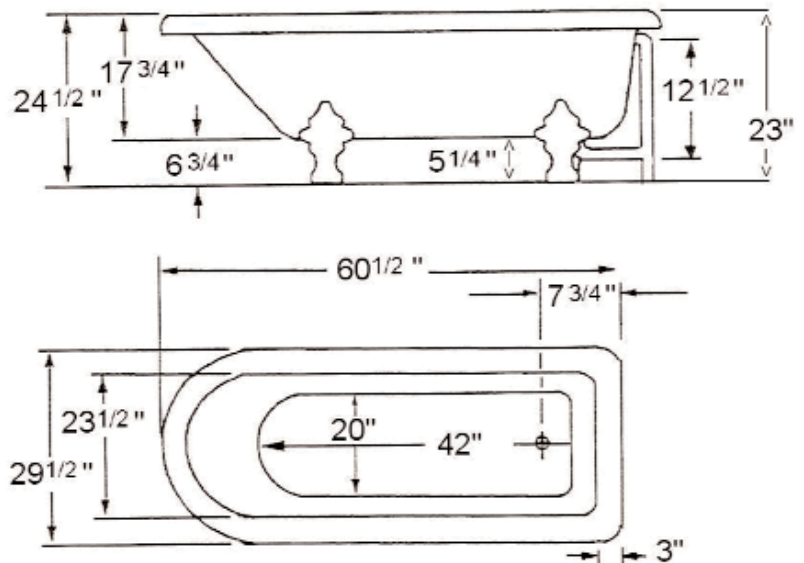

Dimensions of fixture are nominal and specifications subject to change without notice.