

# INFINITY 2

70 x 35 1/2 x 30 3/4 (1780 x 900 x 780)  
inches (mm)

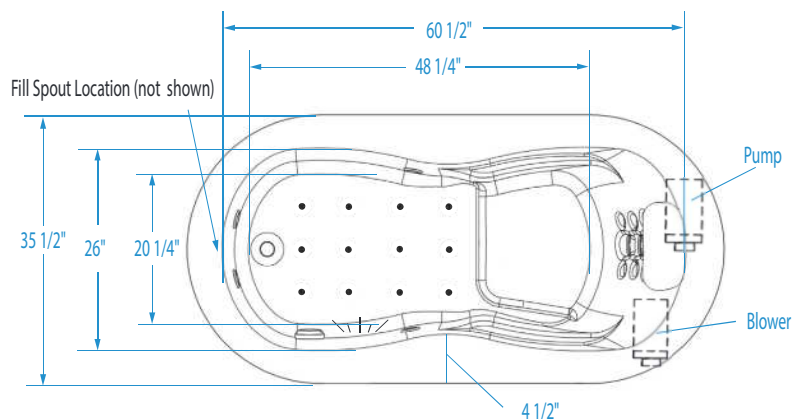

Not a drop-in model. Deck must be built around unit.  
This unit has a 3/4" female waterfall fill spout connection.



No alternate pump location available.

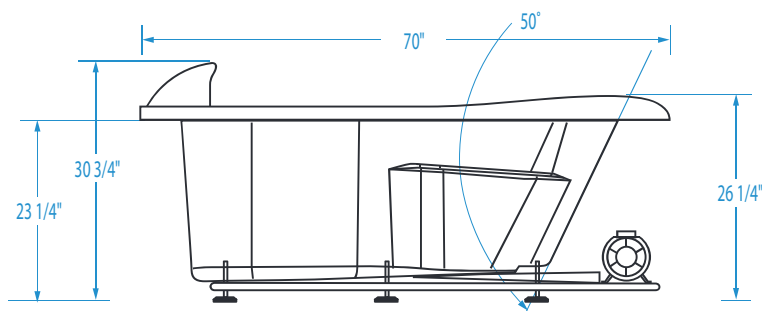

Note: Infinity 2 is not a drop-in model. A deck must be built around the tub.

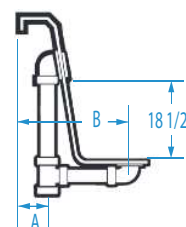

## FEATURES

lbs (kg) Dimensional Tolerance ± 3/8". Dimensions needed for site preparation should be measured from the unit. Aquatic assumes no responsibility for preparatory work.

Type and Model #	Material	Jets	Pump	Air System	Blower	Heater	Controls	Drain	Pkg. Wt.
Air-whirlpool #A12INF7135A	Acrylic	16	1.75 HP	Injector	Variable speed	1.5 kw Inline	Electronic	Universal	356 (161)

## DIMENSIONS

inches (mm)

Width Overall / Net	Depth Overall / Net	Height Overall / Net	Skirt Height
70 (1780)	35 1/2 (900)	30 3/4 (780)	-

## SUMP DATA

inches (mm)

Capacity to Overflow gal (ltr)	Min. Operating Capacity gal (ltr)	WIDTH @ centerline		DEPTH @ centerline	
		Top	Bottom	Top	Bottom
102 (385)	69 (260)	60 1/2 (1535)	48 1/4 (1225)	26 (660)	20 1/4 (515)

## PLUMBING DIMENSIONS

inches (mm)

A	B	Drain Diameter / Clearance
2 3/8 (60)	9 1/2 (240)	2 (50) / 2 3/4 (70)

## ELECTRICAL DATA

Component	Specification	Requirement
Pump	1.75 HP; 12 AMP; 120 V	15 AMP 1 pole, separate circuit, Class A GFCI
Inline Heater	1.5 kW; 12 AMP; 120 V	15 AMP 1 pole, separate circuit, Class A GFCI
Blower	1.0 HP; 9.5 AMP; 120 V	15 AMP 1 pole, separate circuit, Class A GFCI

### NOTES:

1) Where applicable, utilize cut-out templates packed with unit for deck cutouts.

2) 16 x 16 (405 x 405) minimum access required at pump/blower location(s).