



## Intarcia with Pedestal

### 67" x 40" x 24.25"

#### GENERAL SPECIFICATIONS:

Material - Engineered Solid Stone (ESS®)

Installation - Freestanding

Not recommended as a tub / shower combination.

Soaker Weight - 250 lbs / 113 kg

Air Bath Weight - 280 lbs / 127 kg

Maximum Fill - 90 gal to overflow

NOTE: Filling this tub to the maximum may require an above average size or dedicated water heater.

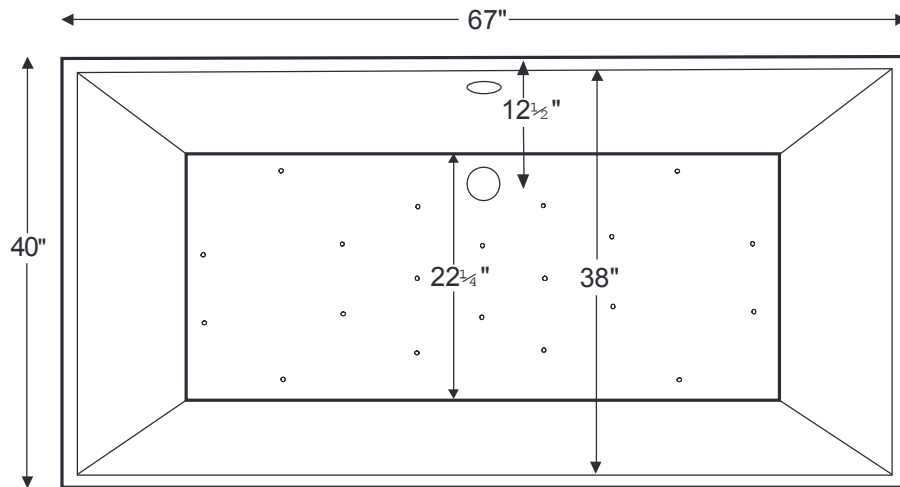

SEE IMPORTANT ORDERING & INSTALLATION INFORMATION BELOW

Shown above as an Air Bath.

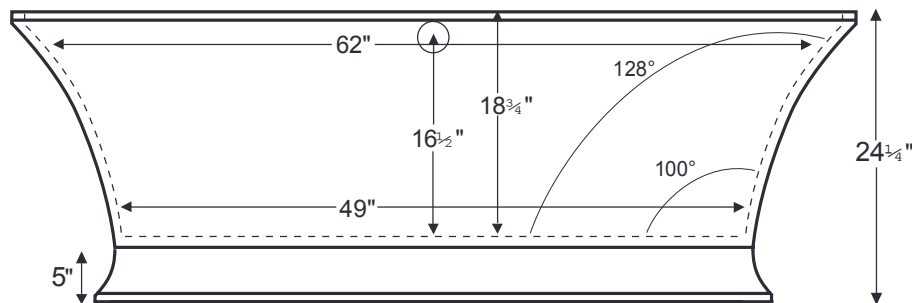

#### ELECTRICAL SPECIFICATIONS:

Required Electrical Service      110 Volt  
Air Bath                                      1-15 amp GFCI

CSA Certified C/US; ANSI Z124.1

See the "Boutique Collection Tubs Installation & Operation Manual" included with tub delivery or go to [mtibaths.com/support/installation\\_operation/manuals](http://mtibaths.com/support/installation_operation/manuals) for all the information necessary to install and operate the tub.

MTI's Customer Service Department is available Monday-Friday 8am-6pm EST at 800-783-8827 or [customerservice@mtibaths.com](mailto:customerservice@mtibaths.com) to answer any questions pertaining to ordering or installation.

#### IMPORTANT ORDERING & INSTALLATION INFORMATION:

- Air baths require job site preparations for remote mounting the blower and required check valve. Check valve must be installed higher than the rim of the tub. The keypad is shipped loose and may be mounted on a nearby wall or decking. A waterproof remote control is also included. Please read installation manual prior to ordering.
- Tub is pre-drilled with an overflow, but can be specified without (see local codes).
- Requires use of a wall-mounted or freestanding tub filler.
- Measurements are  $\pm 1/2"$  and are subject to change without notice.
- Options and accessories are packaged inside the tub crate for delivery.
- Data herein supersedes all prior to publication date shown below.