

**COLUMBUS  
61" CAST IRON  
DOUBLE ROLL  
TOP TUB**

Cat. No.  
CTDRN61



L: 61"  
W: 31 1/2"  
H: 24" (from floor to top of tub)  
18" (from bottom of tub to top of tub)

Depth: 13 1/2" to overflow  
18" at drain

**The following is recommended for CTDRN tubs without faucet holes:**

- Faucets: part #4602
- Rigid, freestanding supplies: part #4502
- Leg tub drain: part #5599

Gallon Capacity: 40  
Shipping Weight: 450 lbs.  
Empty Weight: 270 lbs.  
Filled Weight: 604 lbs.

**Features:**

- ▶ Inside finish is white enamel
- ▶ Imperial feet available in 6 finishes
- ▶ Tub exterior is white (epoxy)
- ▶ No faucet holes
- ▶ Feet are attached and leveled before shipment
- ▶ Tub is thoroughly inspected before shipment

**Foot Finishes:**

**BP** Polished Brass                      **SN** Brushed Nickel  
**CP** Polished Chrome                  **ORB** Oil-rubbed Bronze  
**PN** Polished Nickel                    **WH** White

**Extra Paint Charge** (inside of tub is always white enamel):

**Bisque Paint - \$160**                      **Black Paint - \$160**  
Bathtubs painted in bisque or black are considered "special order" and are not returnable.

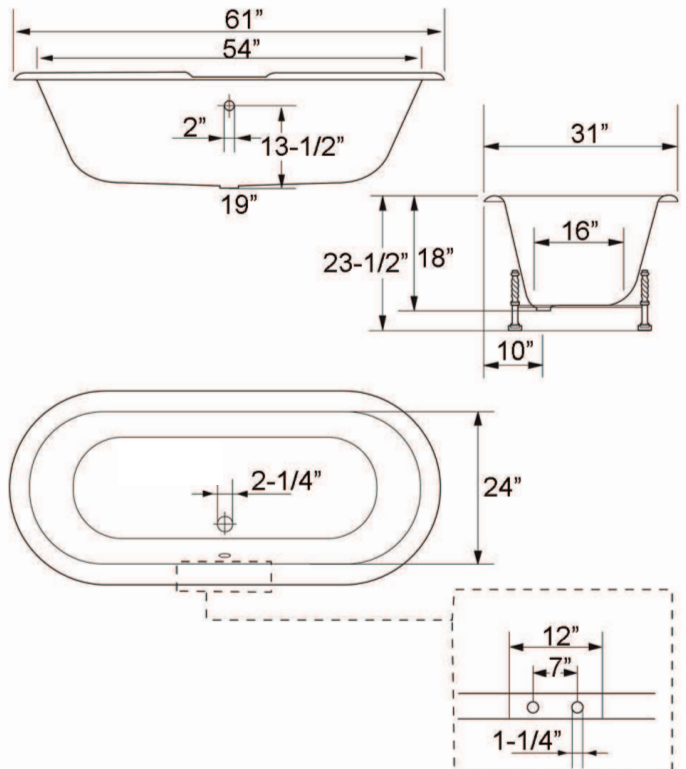

Dimensions of fixture are nominal and may vary within the range of tolerances established by ANSI Standard A112.19.2. Dimensions and specifications subject to change without notice.