

FEATURES:

This product meets and exceeds the following codes and standards

- Meets: ASME A112.18.1-2005/CSAB125.1-2005
- Replacement Cartridge: No. 18.30.011

3/4" In-Line Shut-Off

Valve & Trim

1.002084

Toronto Handle

(1.002084T - Trim Only)

Note: See installation instructions for length of stem required from finished wall.

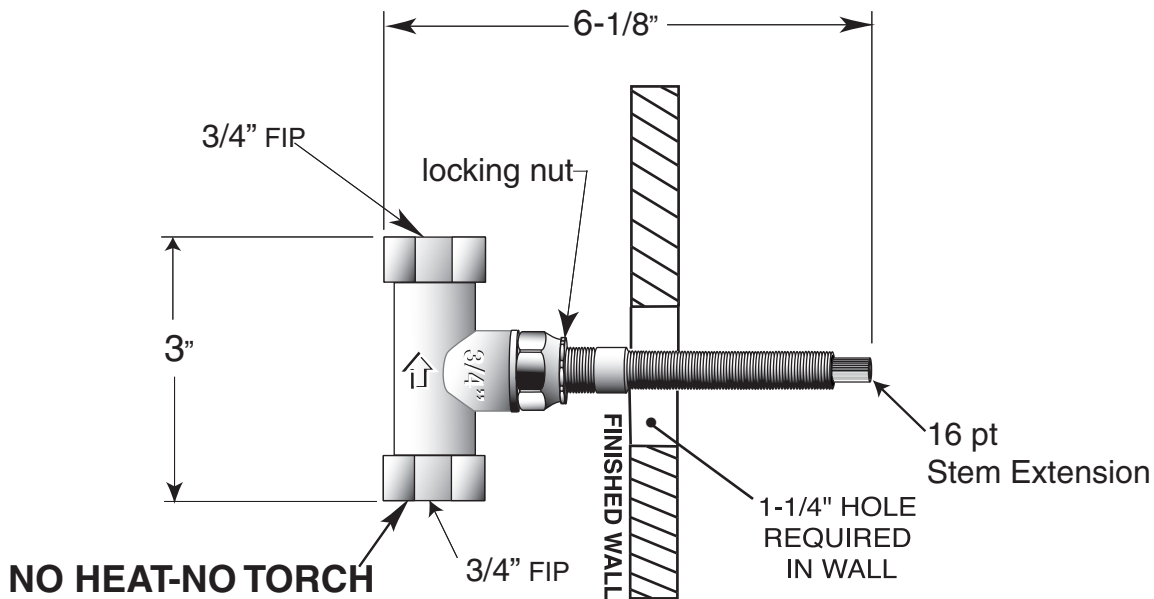
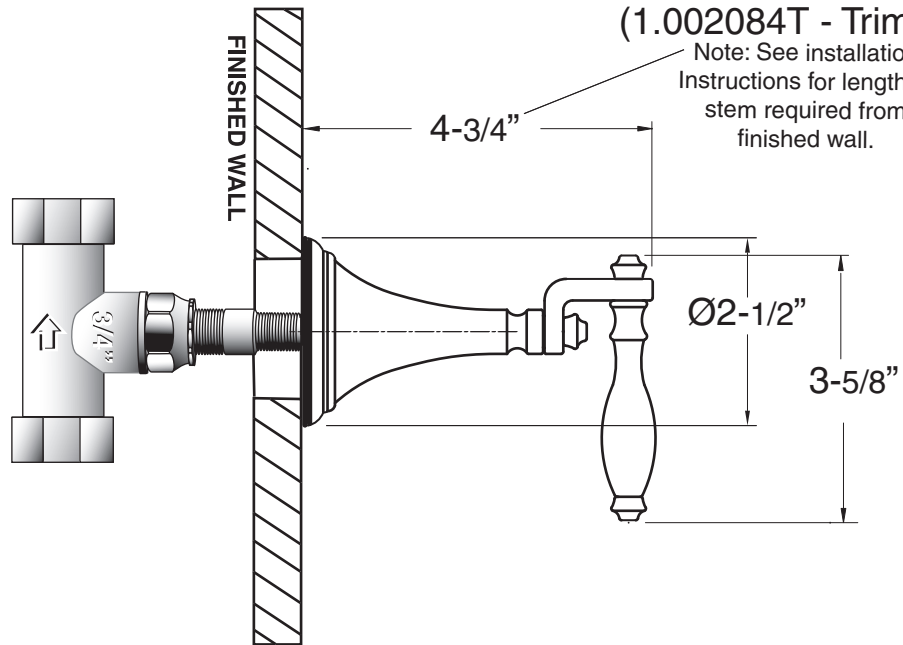

NO HEAT-NO TORCH

Note: Measurements are subject to change or cancellation. No responsibility is assumed for use of superseded or voided pages.