

TechData

SPECIFICATIONS

Series 400

Features:

- Forged brass construction
- Ceramic disk valve cartridge 18.30.865
- Adjustable hot limit safety stop
- Reversible cartridge
- 5.6 GPM @ 45 PSI
- Meets: ASME A112.18.1-2005/CSAB125.1-2005

Pressure Balance Tub & Shower

1.400568

Charlotte Elite Handle

(1.400568T Trim Only)

Cutaway View

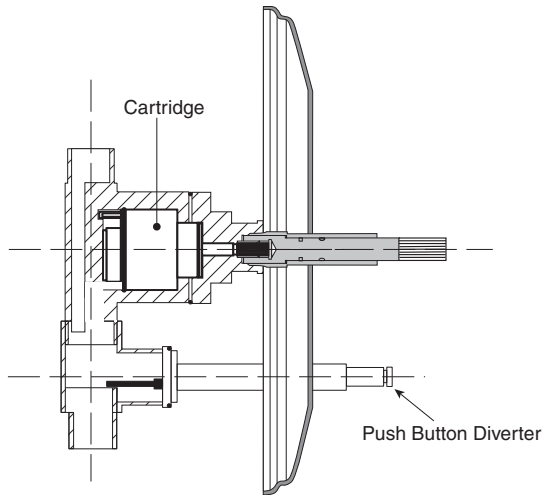

Top View

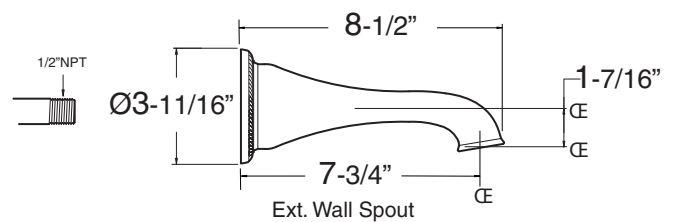
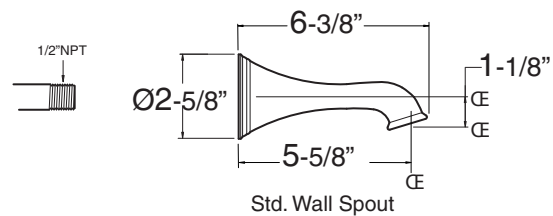
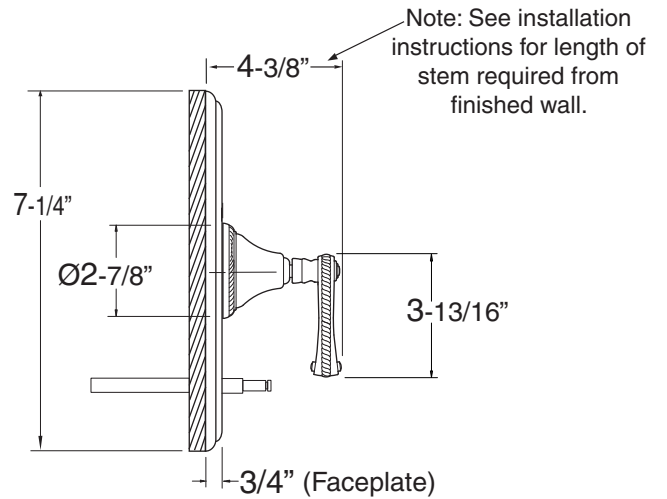
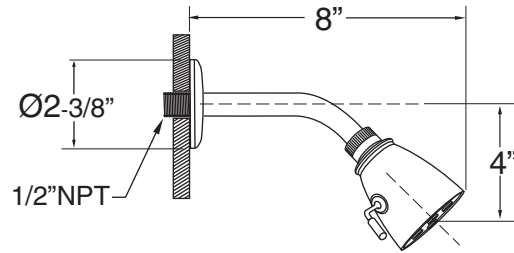
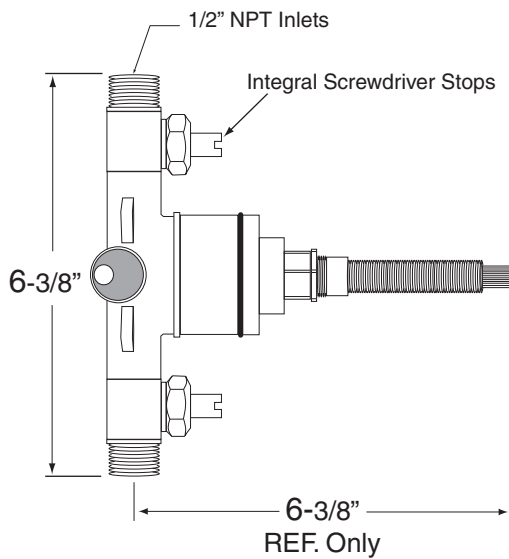

Note: Measurements are subject to change or cancellation. No responsibility is assumed for use of superseded or voided pages.

Parts List Series 400

Charlotte Elite Pressure Balance Tub & Shower Set

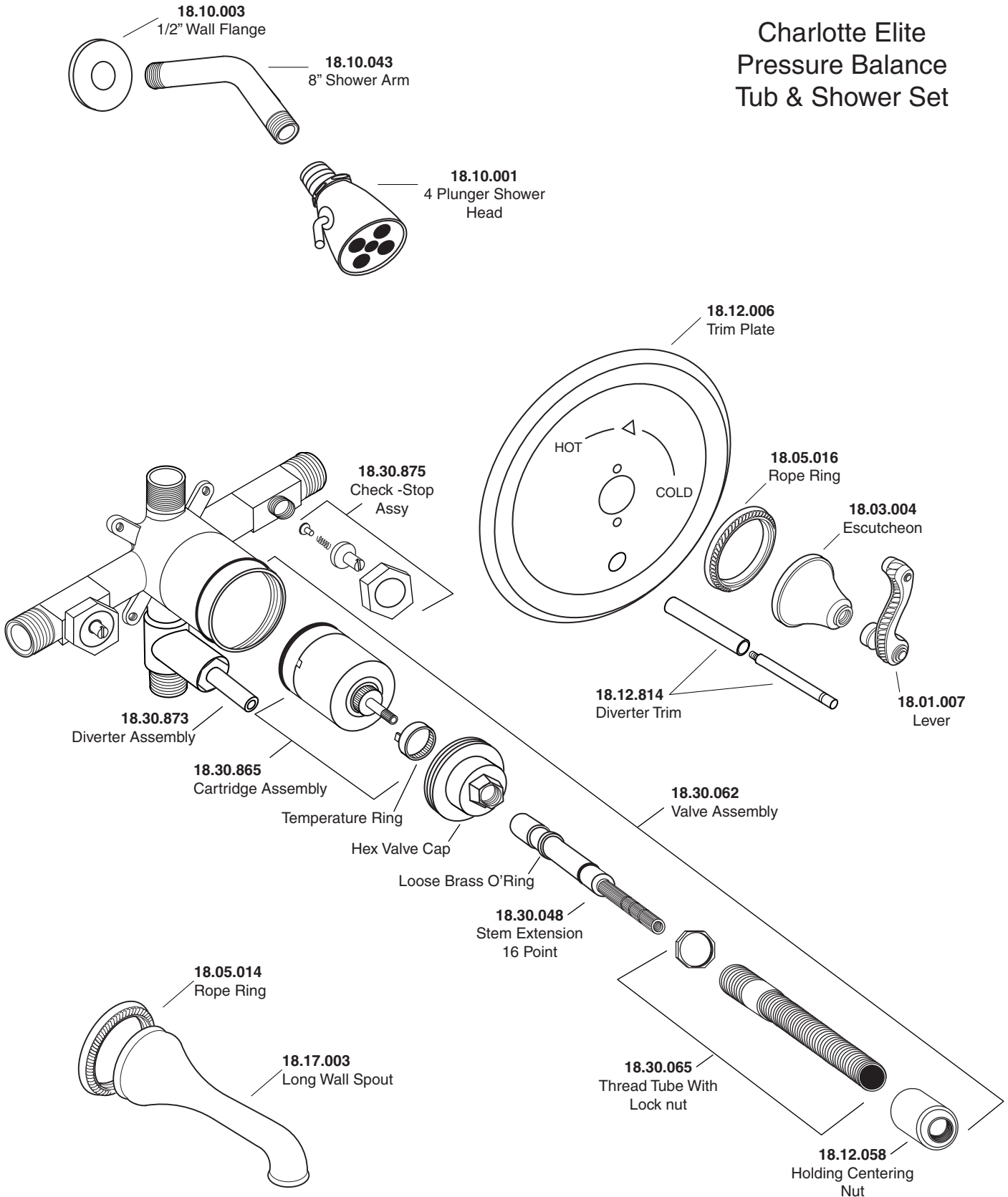

American Faucet & Coatings Corporation.

Tel: 760-598-5895, Toll Free Fax 800-621-8383, customerservice@sigmafaucet.com