

**MONROE  
69" ACRYLIC DOUBLE  
SLIPPER TUB**

Cat. No.  
ADSN69LP



L: 69"  
W: 28 1/2"  
H: 30 3/4"

Water depth: 17" to top of tub

**Features:**

- ▶ Interior and exterior walls acrylic sheets
- ▶ Space between walls partially filled with fiberglass & resin
- ▶ Lion paw feet available in 3 finishes
- ▶ For use with freestanding faucet
- ▶ No faucet holes
- ▶ No overflow
- ▶ Tub feet are attached and leveled before shipment.
- ▶ Tub is thoroughly inspected before shipment

**Feet Finishes:**

**BN** Brushed Nickel                      **PB** Polished Brass  
**CP** Polished Chrome

**The following is recommended for ADSN69LP tubs:**

- Faucets: part #4602, 4022 or 4025
- Rigid, freestanding supplies: part #4502
- Leg tub drain: part #5599LT

Gallon Capacity: 53  
Shipping Weight: 296 lbs.  
Empty Weight: 100 lbs.  
Filled Weight: 543 lbs.

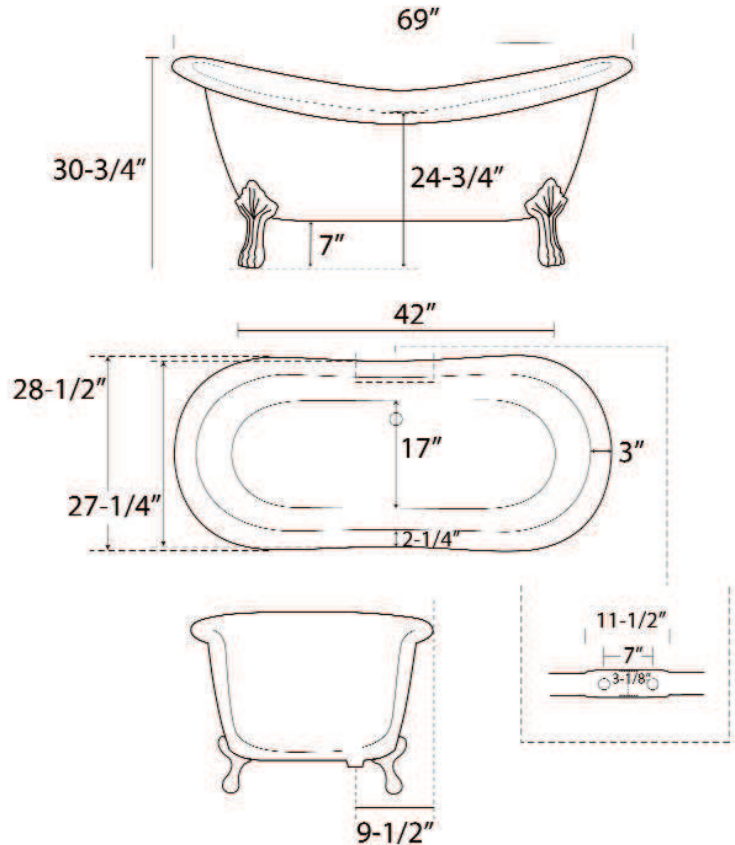

Dimensions of fixture are nominal and specifications subject to change without notice.