

SPECIFICATIONS FOR
HANA

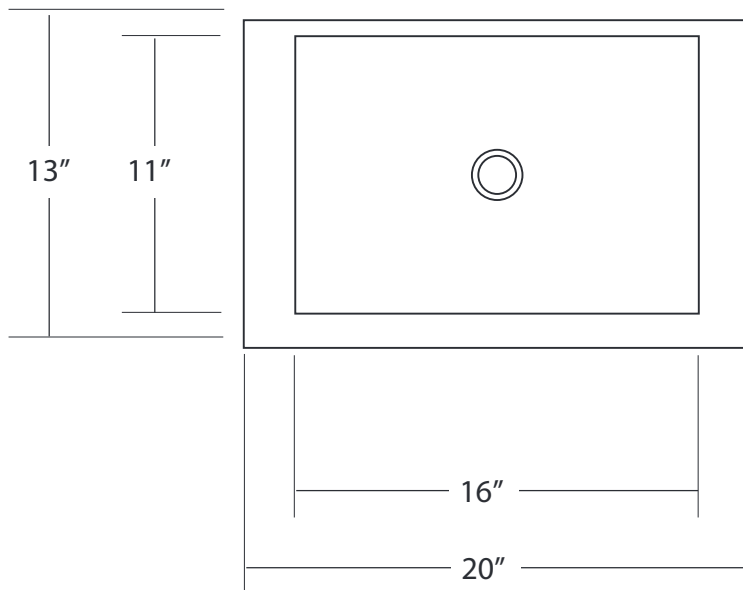

CPS242- Antique
 CPS542- Brushed Nickel

PRODUCT DETAILS

- * 20" x 13" x 5" OD
- * 16" x 11" x 4.5" ID
- * Hand hammered 16 gauge recycled copper
- * 1.5" drain opening
- * Dimensions are not exact and may vary $\pm 1/2"$

INSTALLATION

- * Lavatory
- * Raised Profile

COORDINATING PRODUCTS

- * Drains: DR120, DR150 or DR160

STANDARDS COMPLIANCE

- * IAPMO Listed / cUPC

IMPORTANT

Due to the handcrafted nature of this product, it will vary in finish, texture, hammering, and other details. Dimensions may vary up to 1/2". We strongly recommend that you wait for the actual product before making any installation cuts.

