

*SPECIFICATIONS FOR*  
**1.5" TEARDROP DRAIN**

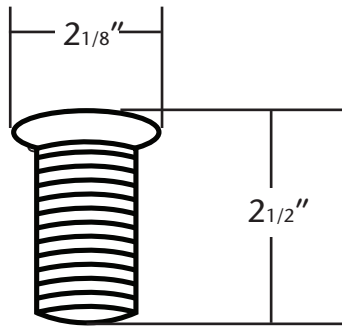

Rubber seal



Plastic washer



Metal nut

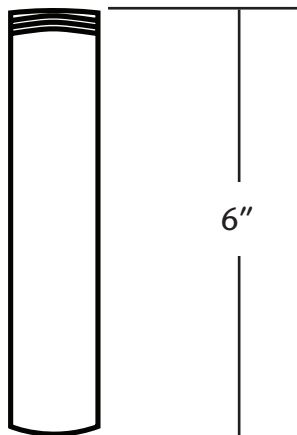

DR150-BN (Brushed Nickel)  
DR150-ORB (Oil Rubbed Bronze)  
DR150-WC (Weathered Copper)

**PRODUCT DETAILS**

- \* Fits 1.5" drain opening
- \* 9 hole lavatory drain provides superior water flow
- \* Maximum threading for easy installation
- \* All exposed parts are plated
- \* Overall length when assembled is 8 1/4"

**COORDINATING PRODUCTS**

- \* Any Native Trails lavatory basin