

**CHRISTIE
COPPER DOUBLE
SLIPPER TUB**

Cat. No.
COTDSN72L



L: 72 1/2"
W: 33"
H: 30"

Rim: 3" W
Overflow hole: 2"
Water depth: 16" to overflow

The following is recommended for COTDSN tubs without faucet holes:

- Free standing faucet: **Part# 4602**
- Free standing bath supplies: **Part# 4502**
- Leg tub drain: **Part# 5599**

Gallon Capacity: 77
Shipping Weight: 425 lbs.
Empty Weight: 200 lbs.
Filled Weight: 843 lbs.

Features:

- ▶ Made of 16 gauge copper
(Copper is a living finish and will patina over time)
- ▶ Smooth antique finish
- ▶ Hand polished
- ▶ Double Slipper
- ▶ Includes base
- ▶ No faucet holes

Tub Finishes:

SAC Smooth Antique Copper

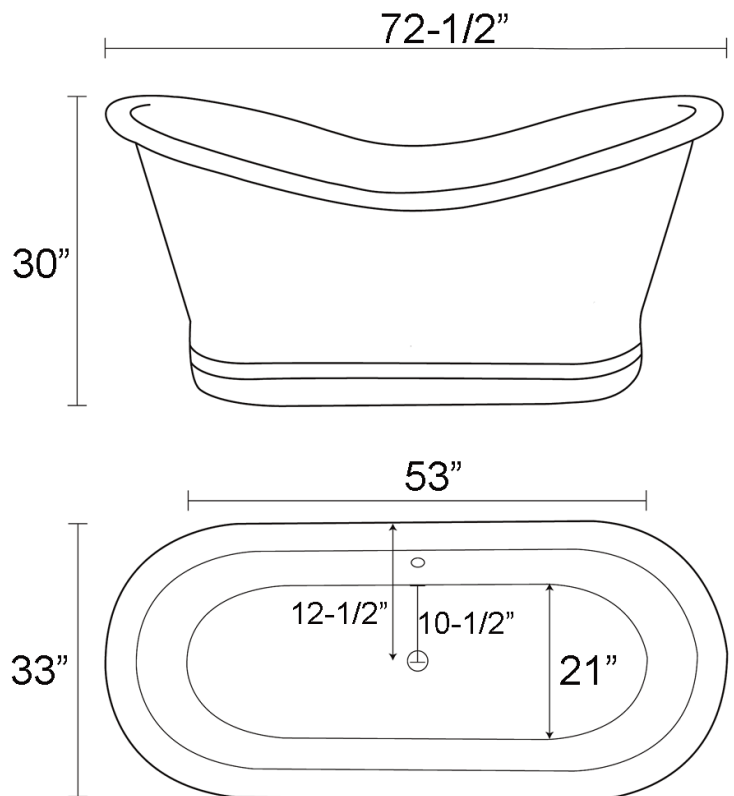

Dimensions and specifications subject to change without notice.