

**COLIN
70" ACRYLIC DOUBLE
ROLL TOP TUB**

Cat. No.
ADRN70LP



L: 70"
W: 31 3/4"
H: 23 3/4"

Water depth: 16 1/4" to top of tub

The following is recommended for ADRN70LP tubs:

- Faucets: part #4602, 4022 or 4025
- Rigid, freestanding supplies: part #4502
- Leg tub drain: part #5599LT

Gallon Capacity: 57
Shipping Weight: 425 lbs.
Empty Weight: 200 lbs.
Filled Weight: 676 lbs.

Features:

- ▶ Interior and exterior walls acrylic sheets
- ▶ Space between walls partially filled with fiberglass & resin
- ▶ Lion paw feet available in 3 finishes
- ▶ No faucet holes
- ▶ No overflow
- ▶ Tub feet are attached and leveled before shipment.
- ▶ Tub is thoroughly inspected before shipment

Feet Finishes:

BN Brushed Nickel **PB** Polished Brass
CP Polished Chrome

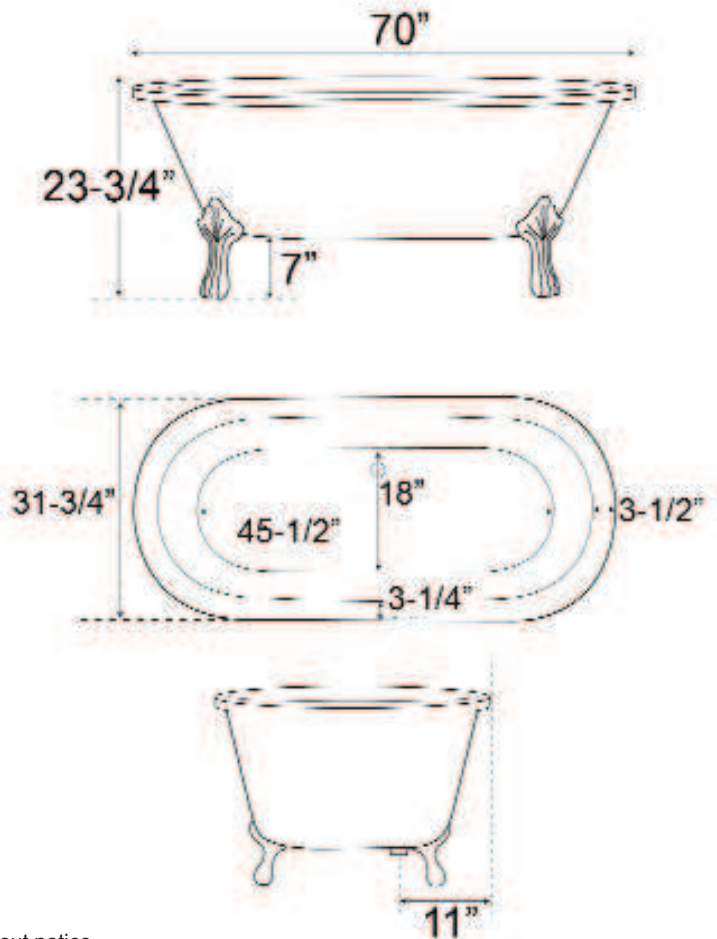

Dimensions of fixture are nominal and specifications subject to change without notice.