

# EXTENDED TUB DRAIN

Cat. No.  
5599E



## Features:

- ▶ Twist-and -Lift Stopper
- ▶ Extended 19" Drain Pipe
- ▶ Extended 19" Overflow Tube
- ▶ Extended Tubes Can be Cut to Size
- ▶ 1-1/2" Tubing
- ▶ Includes Floor Flange and Overflow Plate
- ▶ Available in 6 Finishes

## Finishes:

<b>AC</b>	Antique Copper	<b>CP</b>	Polished Chrome
<b>BN</b>	Brushed Nickel	<b>PN</b>	Polished Nickel
<b>ORB</b>	Oil Rubbed Bronze		

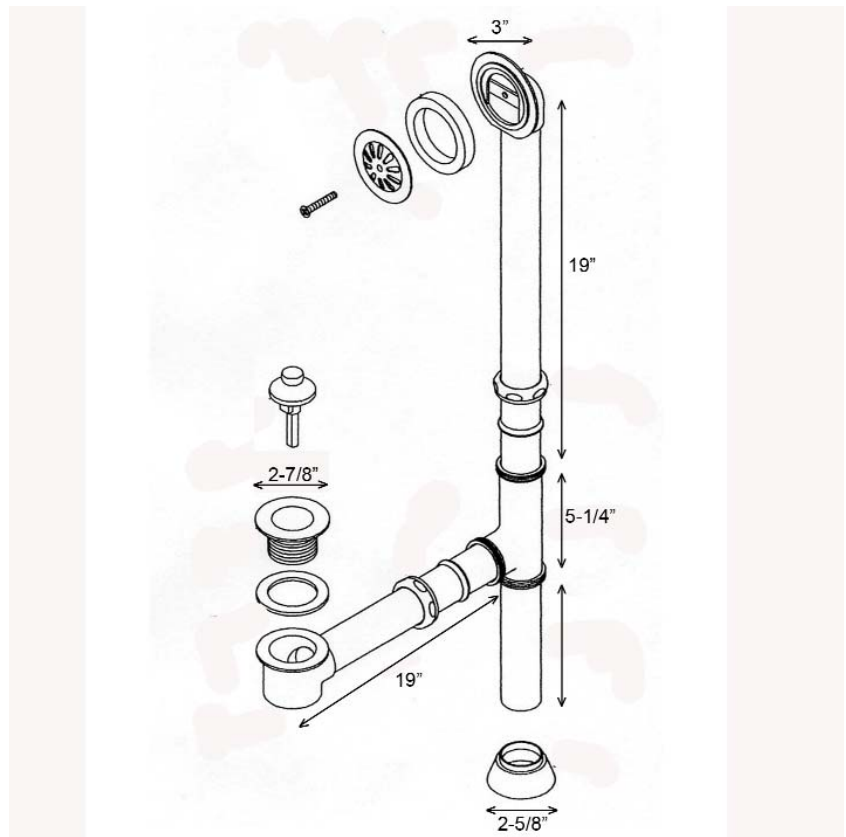

Dimensions and specifications subject to change without notice.