

Date: \_\_\_\_\_

Client: \_\_\_\_\_

Project: \_\_\_\_\_

VOLA product: 4113



**4113**

Build-in basin mixer with on-off sensor for 'hands free' operation.  
 4113UP = Mixer 4100.  
 4113AP = Handle NR41, sensor 4000S, 160 mm spout Ø10, 60 x 309 mm cover plate 3003.  
 Valve box for electronic mixer, VR2618 enclosed.

**Flow**

	Bar:	1,0	2,0	3,0	4,0	5,0
4113	(l/min)	5,0	5,0	5,0	5,0	5,0

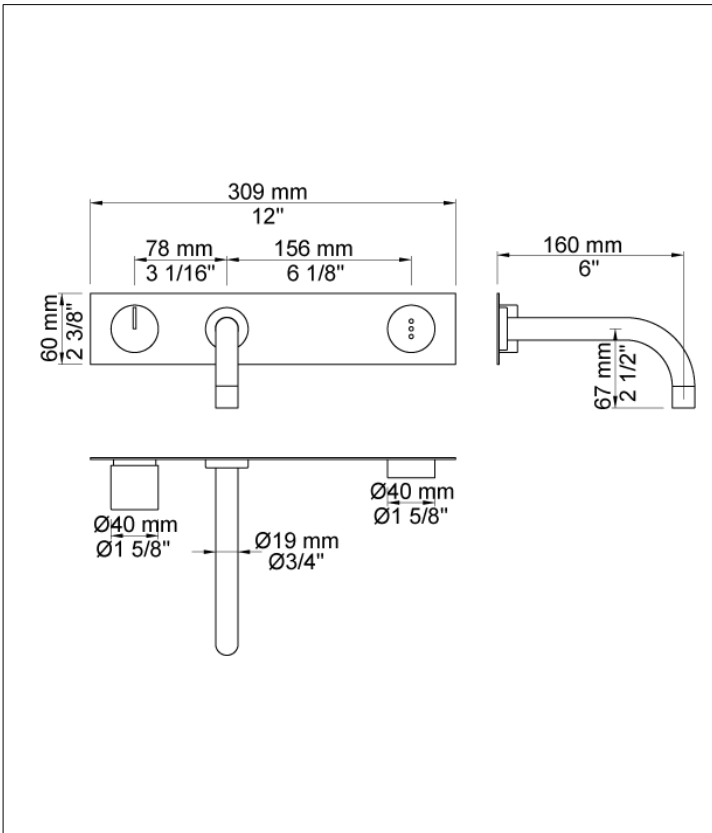

**Available in colours**

- Color 02, Grey
- Color 04, Light blue
- Color 05, Orange
- Color 06, Light green
- Color 08, Yellow
- Color 09, Dark grey
- Color 12, Mocca
- Color 14, Bright red
- Color 15, Dark blue
- Color 16, Polished chrome
- Color 17, Gloss black
- Color 18, White
- Color 19, Natural brass
- Color 20, Brushed chrome
- Color 21, Carmine red
- Color 25, Pink
- Color 27, Matt black
- Color 40, Brushed stainless steel



Date:

Client:

Project:

VOLA product: 4113

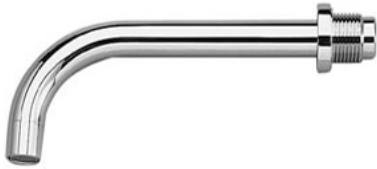

**010**  
160 mm fixed spout with water saving aerator.

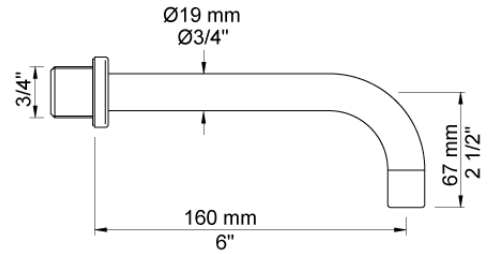

**3003**  
Three-hole plate, 60 x 309 mm.  
Holes Ø36, Ø33 and Ø33 mm.

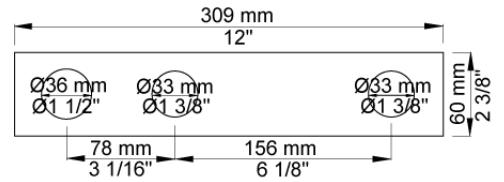

**4000S**  
Sensor

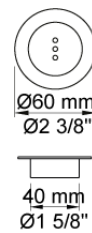

Date:

Client:

Project:

VOLA product: 4113

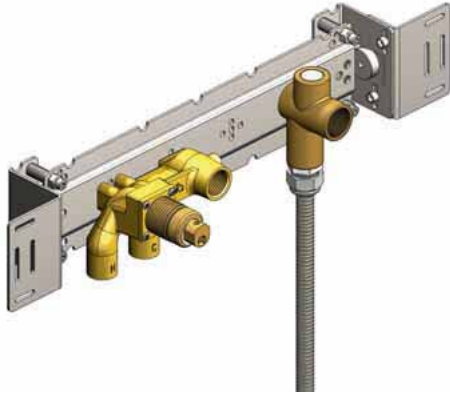

**4100**  
Build-in basin mixer with on-off sensor for 'hands free' operation, with temperature regulation.

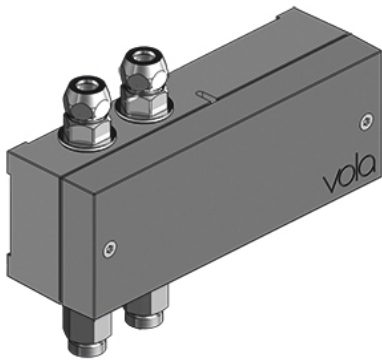
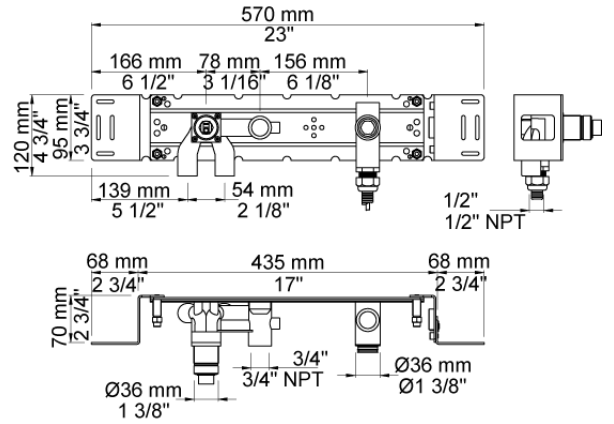

**VR2618**  
Box for electronic HV1E/4100

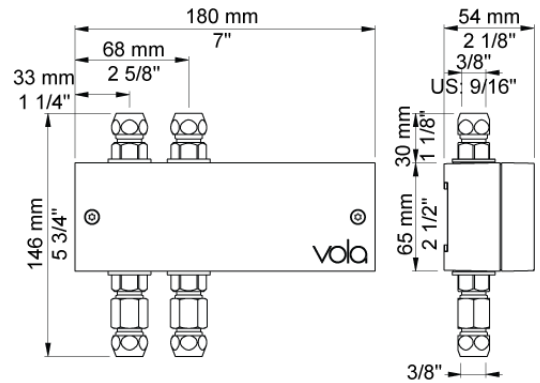

**NR41**  
Temperature control handle for wall-mounted electronic mixer 4100.

