

Date:

Client:

Project:

VOLA product: 701



701

Two-handle build-in mixer with ¼ turn ceramic disc technology.
 701 UP = Build-in mixer 700V.
 701 AP = 2 pcs. handle NR17, 2 pcs. 60 mm circular flanges 001.

Flow

	Bar:	1,0	2,0	3,0	4,0	5,0
700V	(l/min)	37,5	53,1	65,0	75,1	83,9

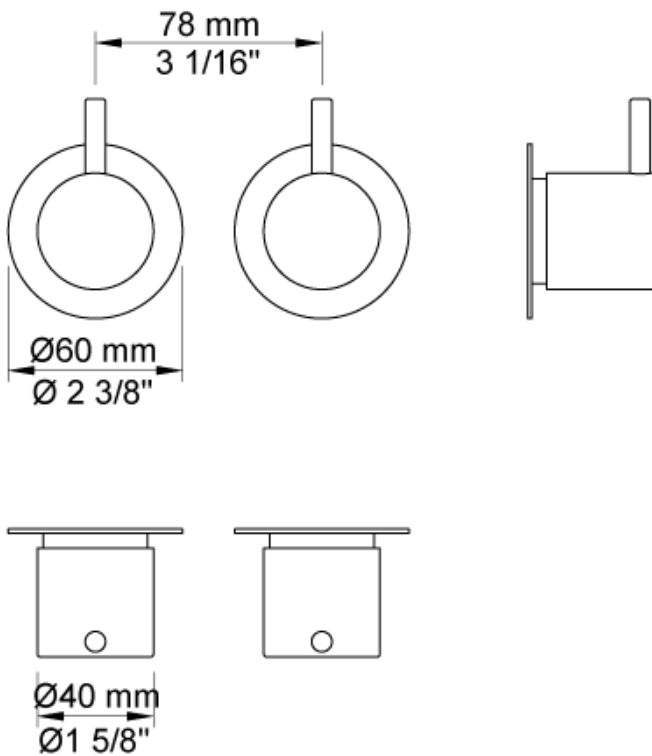

Available in colours

- Color 02, Grey
- Color 04, Light blue
- Color 05, Orange
- Color 06, Light green
- Color 08, Yellow
- Color 09, Dark grey
- Color 12, Mocca
- Color 14, Bright red
- Color 15, Dark blue
- Color 16, Polished chrome
- Color 17, Gloss black
- Color 18, White
- Color 19, Natural brass
- Color 20, Brushed chrome
- Color 21, Carmine red
- Color 25, Pink
- Color 27, Matt black
- Color 40, Brushed stainless steel



Date:

Client:

Project:

VOLA product: 701

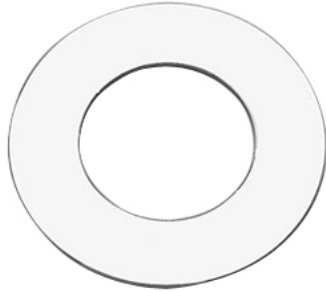

001
60 mm circular flange.
Hole Ø33 mm.

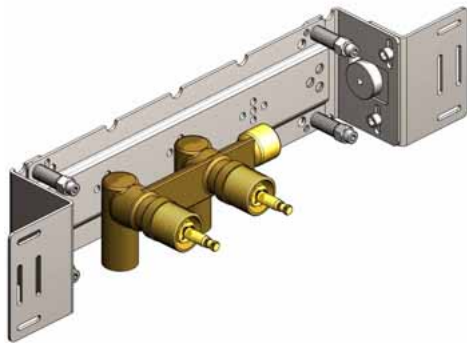

700V
Two-handle build-in mixer.
1/2" connection to copper, steel, iron or pex pipe work.

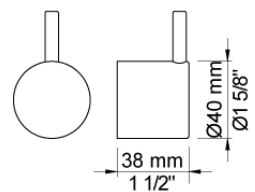
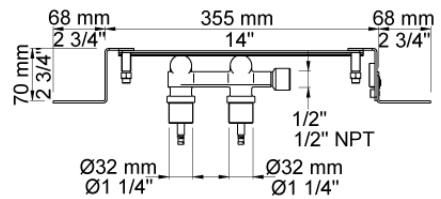
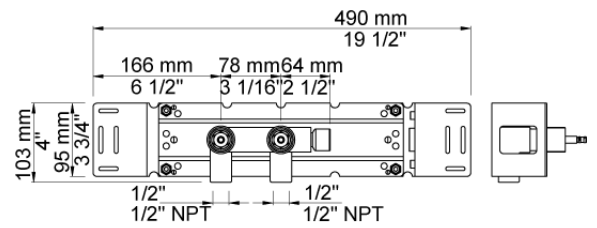

NR17
Operating handle for 600, 700, 800, 900, 1500, S20, S21, S40, S42 incl. variants. Ø40 mm.