

V161-AIS

Dual control valve rough

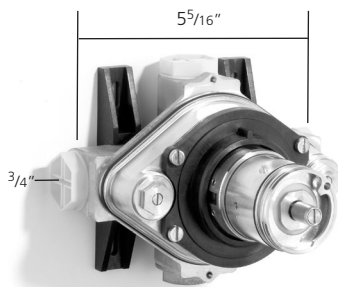

Finishes: XX

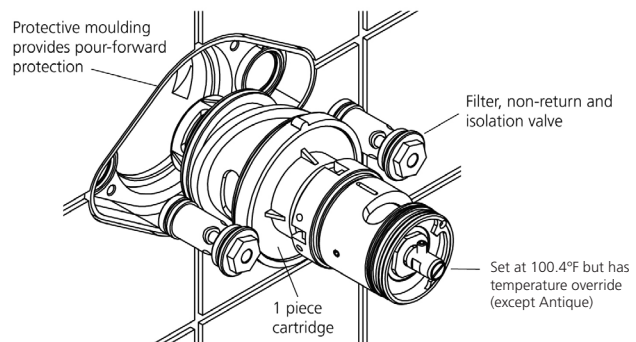
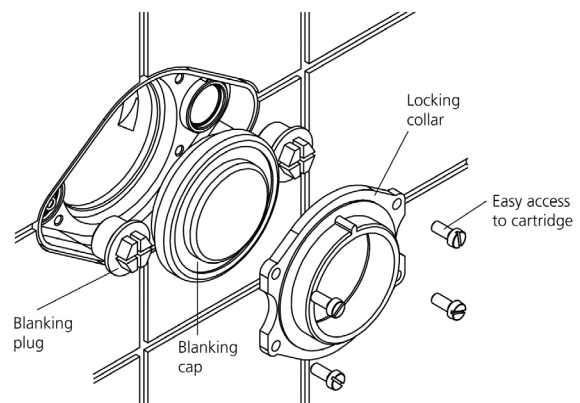
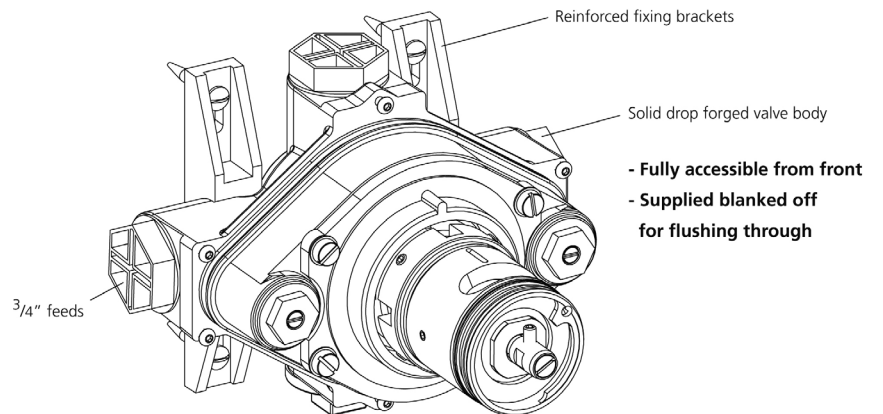

25mm / 1" extension kits are available

UK and Worldwide Customer Service Team:
+44 (0)121 766 4200
www.samuel-heath.co.uk

USA Customer Service Team:
www.samuel-heath.com