

SPECIFICATIONS FOR
36" CUZCO VANITY

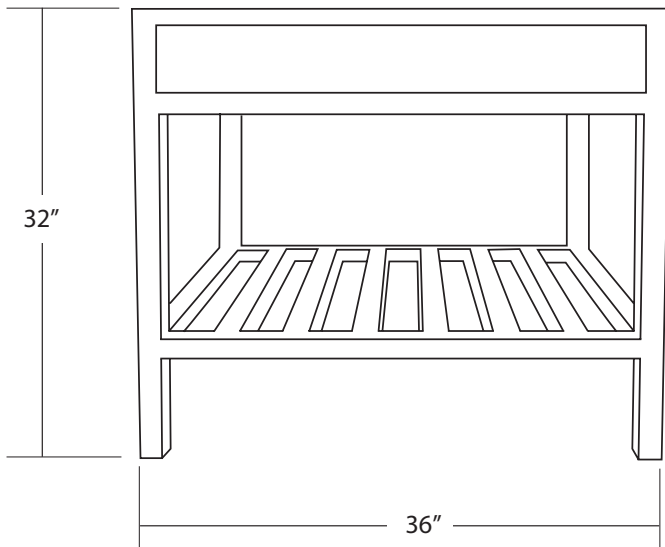

VNR362- Antique
VNR365- Brushed Nickel



PRODUCT DETAILS

- * 36" x 21.5" x 32"
- * Wrought iron
- * Hand hammered 16 gauge recycled copper
- * Dimensions are not exact and may vary $\pm 1/2"$

INSTALLATION

- * Freestanding vanity base

COORDINATING PRODUCTS

- * Native Trails stone or Sedona vanity tops
- * Decorative bottle trap

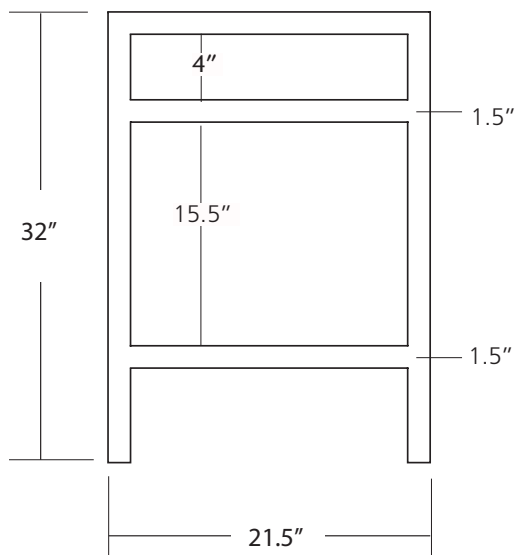

IMPORTANT

Due to the handcrafted nature of this product, it will vary in finish, texture, hammering, and other details. Dimensions may vary up to 1/2". We strongly recommend that you wait for the actual product before making any installation cuts.