

SPECIFICATION SHEET

PRODUCT FAMILY: **Waste Management** FINISH: **other** SERIES: **WASTE DISPOSERS** MODEL: **FWD100R**

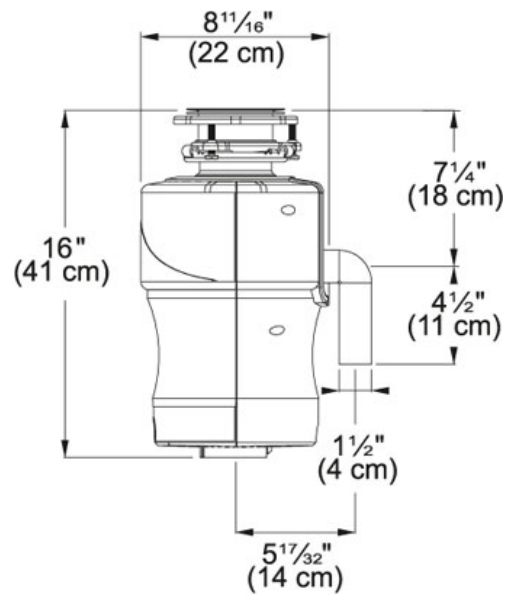

Product Information

FUN# 134.0297.202

US Part Number FWD100R

RPM 2800

Horse Power 1 HP

* Continuous Feed models may require Air Switch WD3428 and Controller WD9088.
Chrome stopper and flange standard on each disposer not available separately.
WD8026SN and WD8027C not compatible with this model.