

Date:

Client:

Project:

VOLA product: 1521



1521

Two-handle build-in mixer with ¼ turn ceramic disc technology.
 1521UP = Mixer 1500.
 1521AP = 2 pcs. handles NR17, 225 mm fixed spout 020, 3 pcs. 60 mm circular flanges 001.

Flow

	Bar:	1,0	2,0	3,0	4,0	5,0
1521	(l/min)	5,0	5,0	5,0	5,0	5,0

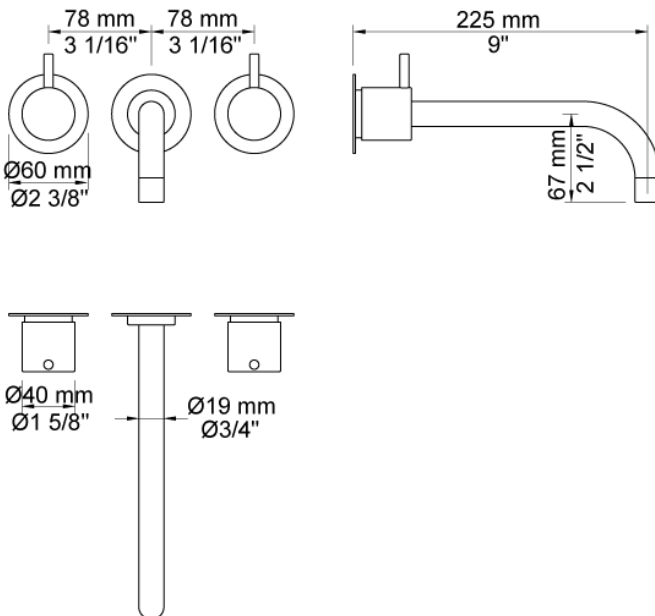

Available in colours

- Color 02, Grey
- Color 04, Light blue
- Color 05, Orange
- Color 06, Light green
- Color 08, Yellow
- Color 09, Dark grey
- Color 12, Mocca
- Color 14, Bright red
- Color 15, Dark blue
- Color 16, Polished chrome
- Color 17, Gloss black
- Color 18, White
- Color 19, Natural brass
- Color 20, Brushed chrome
- Color 21, Carmine red
- Color 25, Pink
- Color 27, Matt black
- Color 40, Brushed stainless steel



Date:

Client:

Project:

VOLA product: 1521

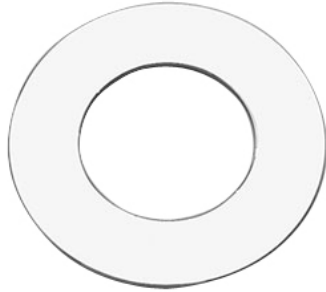

001
60 mm circular flange.
Hole Ø33 mm.



020
225 mm fixed spout with water saving aerator.

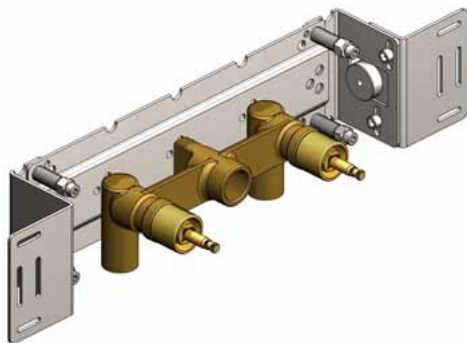
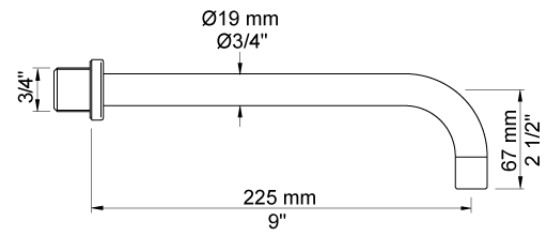

1500
Two-handle build-in mixer, with outlet in the middle.
1/2" connection to copper, steel, iron or pex pipe work.

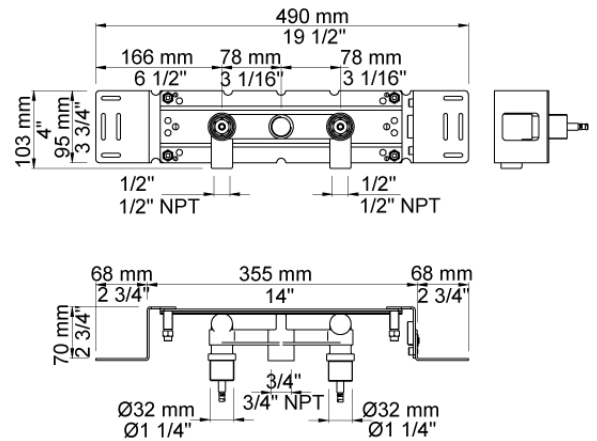

Date:

Client:

Project:

VOLA product: 1521



NR17

Operating handle for 600, 700, 800, 900, 1500, S20, S21, S40, S42 incl. variants. Ø40 mm.

