

*SPECIFICATIONS FOR*  
**2" JR. STRAINER**

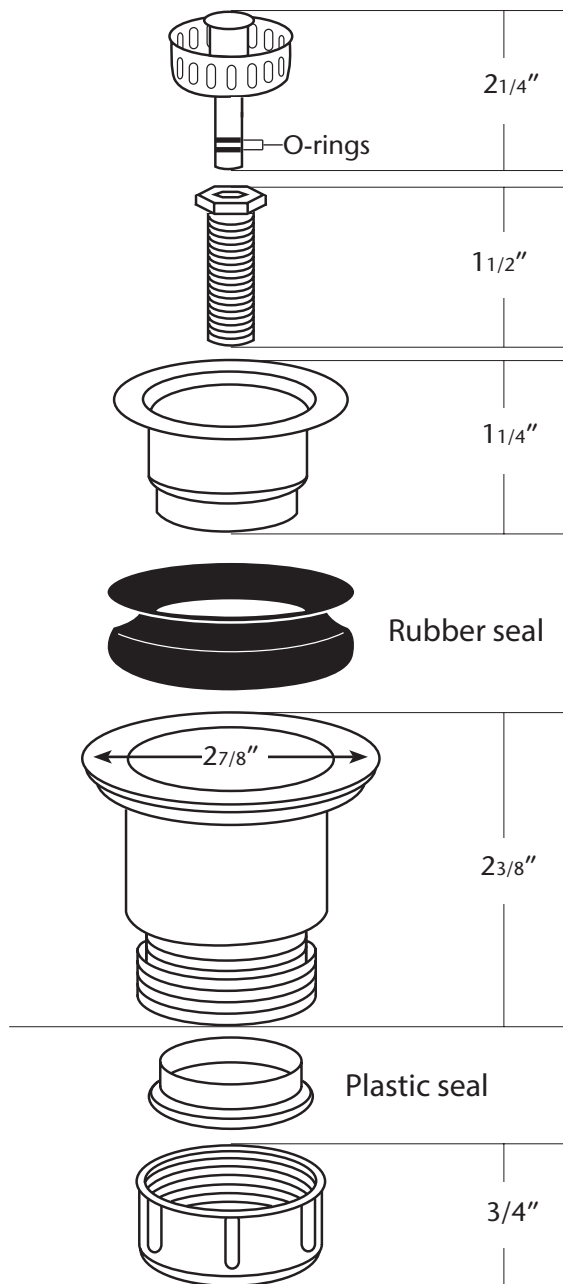

DR220-BN (Brushed Nickel)  
 DR220-ORB (Oil Rubbed Bronze)  
 DR220-WC (Weathered Copper)  
 DR220-SC (Solid Copper)

**PRODUCT DETAILS**

- \* Fits 2" drain opening
- \* Long lasting stem with durable O-ring seals
- \* Overall length when assembled is 2 3/4"

**COORDINATING PRODUCTS**

- \* Diego and Small Square