

SEAMLESS™ MIRRORED CABINET

Hospitality Performance Specification



The Seamless™ Mirrored Cabinet hides an ultra-thin HDTV behind almost vanishing mirror reflection, seamlessly integrating technology within clean reflective layers. The first mirrored cabinet with an integrated LED HDTV in an ultra thin mirrored door.

THERE'S ONLY ONE ELECTRIC MIRROR™

Electric Mirror is the global leader in lighted mirrors and mirror TV technology. With unparalleled customer service and amazing innovation, Electric Mirror is the standard of luxury for five-star hotels, upscale commercial projects and designer homes.

FEATURES

- 15.6" LED HDTV and integrated audio
- Defogger (10.5" x 10.5") with internal switch
- Exceptional mirror reflectivity
- Sleek double-sided 3/4" mirrored door
- Mirrored interior
- Matte silver aluminum cabinet body
- Adjustable Diamond Clear™ extra white glass shelves
- HardCoat™ anti-corrosion mirror treatment
- 170 degree door opening angle (soft close)
- Interior 20 Amp, 120 VAC GFCI receptacle with two electrical outlets
- Rust resistant anodized aluminum chassis construction
- Proudly made in the USA
- Patent pending

LIGHTING

- Natural light color - Ideal for makeup application
- Power buttons for lights and defogger inside cabinet
- 50,000 hour energy efficient LED lighting
- CRI 85
- CCT (K) 3000

TV/AUDIO

- 15.6" LED HDTV integrated into mirror door
- AV mirror technology provides reflective surface when TV is off
- GlassWaves™ audio integrated into mirror door
- 720p, 1080i, 16:9 widescreen ratio
- Waterproof buoyant remote included
- HDMI and RF input
- ATSC/NTSC QAM TV Tuner
- Ideal 10 watt per channel integrated amplification

OPTIONS

- Left hinge (LT) or right hinge (RT)
- Recessed (RM) or surface mount (SM) includes mirror side kit
- 3/4" beveled edge
- 240 VAC version available
- Bose™ ceiling speaker
- IR Control
- V Mirror Technology - totally vanishing TV
- Left/Right audio out

SAFETY

- Tested to UL/U-C 962
- LED mercury free environmentally sustainable TV back lighting
- Designed for humid bathroom environments
- FCC Compliant

SEAMLESS™ MIRRORED CABINET

Hospitality Performance Specification

SPECIFICATION

- The top of the mirrored cabinet above the bathroom vanity should be a minimum of 6' 6" above the finished floor.
- Electrical connections made with MC cable brought through the cabinet knockout, no electrical box required.
- Cabinet should be on a 20 amp unswitched circuit to accommodate a GFCI.
- Fixture should be mounted to wall studs to provide sufficient support. Mounting holes are provided in the cabinet.
- For surface mounted versions, hanging hardware is provided.

MODEL NUMBER	DIMENSIONS	POWER REQUIREMENTS
REC-156-AV-23.25x40.00*	23.25" W x 40" H x 4" D 591mm x 1016mm x 102mm	120 VAC, .54 Amps, 65W, 20 amp GFCI

*When making order, please note the following preferences: Right Hinge (RH) or Left Hinge (LH), Recessed Mount (RM) or Surface Mount (SM).

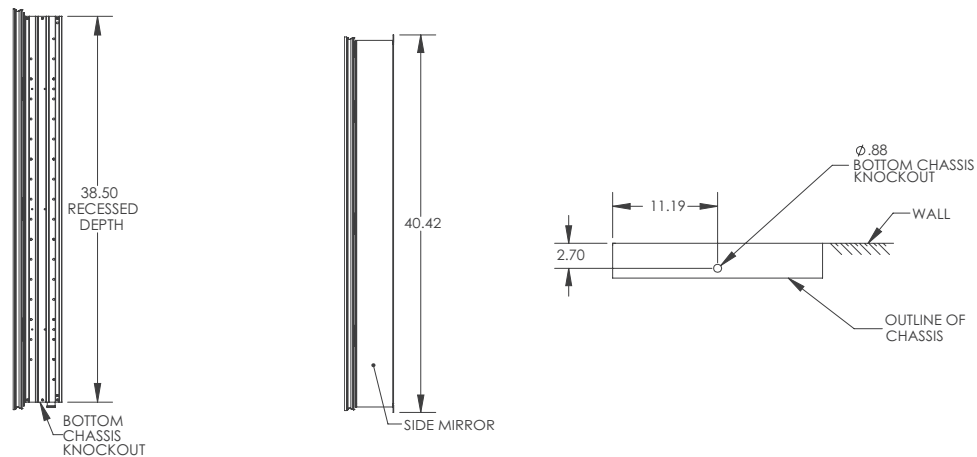
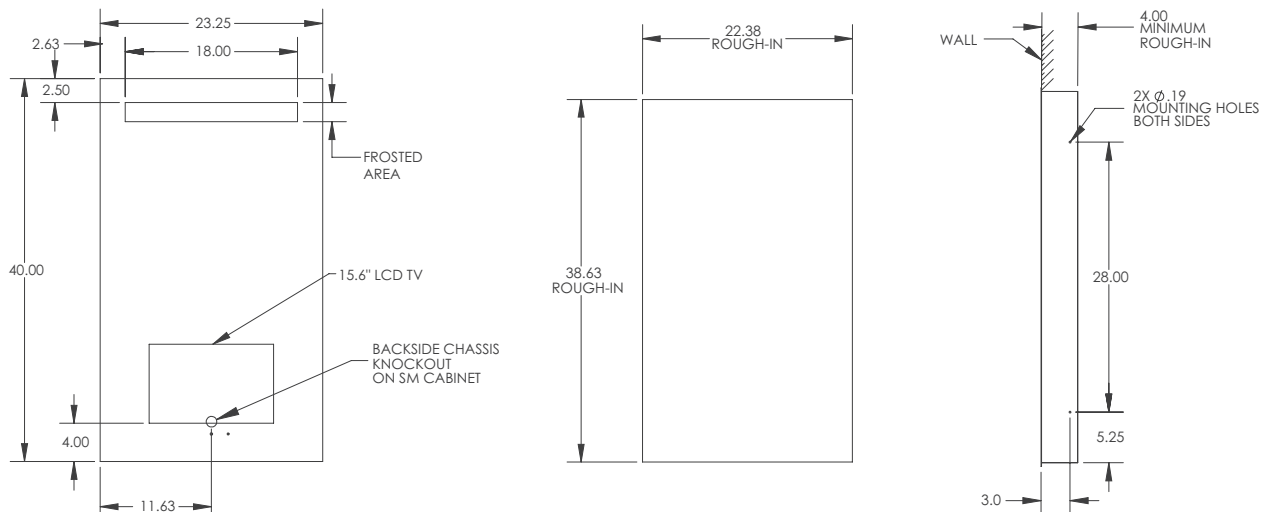

PROPRIETARY AND CONFIDENTIAL: The information contained in this specification is the sole property of Electric Mirror®. Any reproduction in part or in whole without written permission from Electric Mirror® is prohibited.

© 2012 ELECTRIC MIRROR®