

**Sanitet/Sanitary**



---

no 7825.00

---

VVS 772784816

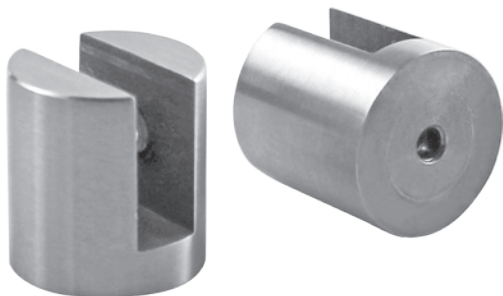

**DK** Glashylde holder Ø 25 X 26mm

- Leveres i slebet matbørstet rustfrit stål (AISI 304)
- Passende for hylde i 8-12mm tykkelse
- incl. skruer og raw plugs

**EN** Glassshelf holder Ø 25 X 26mm

- Available in satin stainless steel (AISI 304)
- Suitable for shelves in 8-12mm thickness
- incl. screws and plugs

---

Tegninger · Drawings

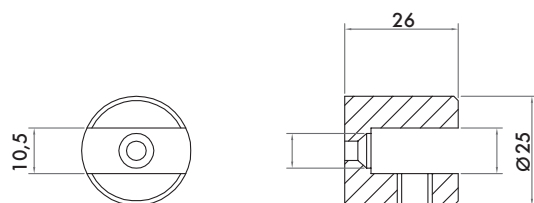

no 7826.00

VVS 772783116

**DK Hjørneglashylde i matteret hærdeet glas 8 x 150 X 150mm**

- Leveres som sæt incl. 2 stk Ø 25 X 26mm hyldeholdere, i slebet matbørstet rustfrit stål (AISI 304)
- incl. skruer og raw plugs

**EN Corner glass shelf, frosted hardened glass, 8 x 150 X 150mm**

- Available as set incl. 2 pcs Ø 25 X 26mm shelf holders, satin stainless steel (AISI 304)
- incl. screws and plugs

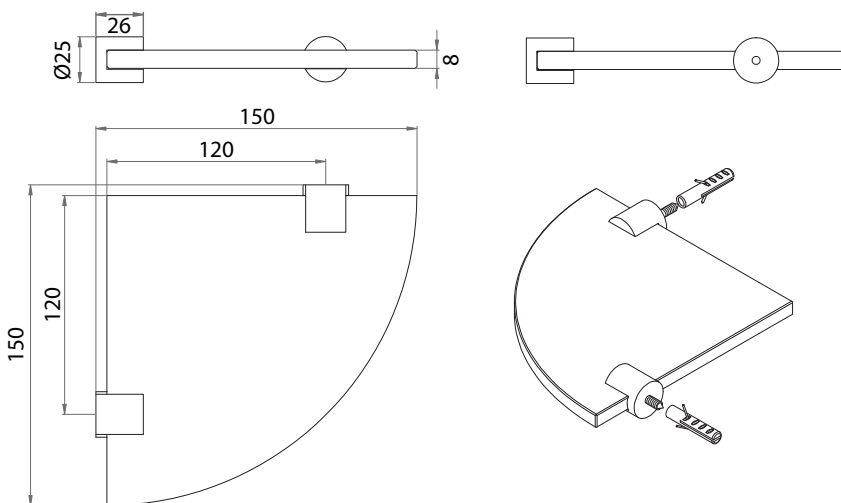
**Tegninger · Drawings**

no 7826.05

VVS 772782116



**DK** Glashylde i matteret hærdeet glas 8 x 150 x 500mm

- Leveres som sæt incl. 2 stk Ø16 x 163 mm hyldeholdere, i slebet matbørstet rustfrit stål (AISI 304)
- incl. skruer og raw plugs

**EN** Glass shelf, frosted hardened glass, 8 x 150 x 500mm

- Available as set incl. 2 pcs Ø16 x 163 mm shelf holders, satin stainless steel (AISI 304)
- incl. screws and plugs

Tegninger · Drawings

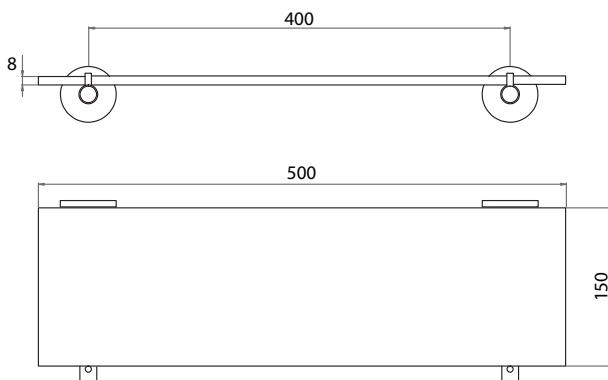

no **7826.06**

VVS 772782216

**DK** Glashylde i matteret hærdeet glas 8 x 200 x 600mm

- Leveres som sæt incl. 2 stk Ø16 x 216 mm hyldeholdere, i slebet matbørstet rustfrit stål (AISI 304)
- incl. skruer og raw plugs

**EN** Glass shelf, frosted hardened glass, 8 x 200 x 600mm

- Available as set incl. 2 pcs Ø16 x 216 mm shelf holders, satin stainless steel (AISI 304)
- incl. screws and plugs

## Tegninger · Drawings

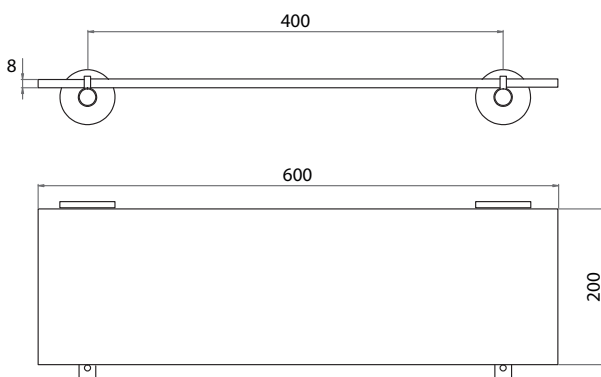

no 7833.00

VVS 774034116



**DK** Glasholder med glas

- Leveres i slebet matbørstet rustfrit stål (AISI 304)
- incl. skruer og raw plugs

**EN** Glass holder with glass

- Available in satin stainless steel (AISI 304)
- incl. screws and plugs

Tegninger · Drawings

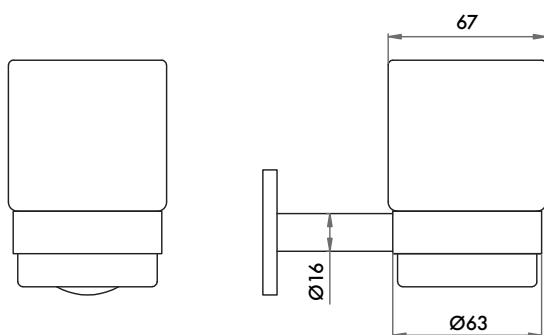

no 7852.00

VVS 774737516



**DK** Sæbedispenser 170ml, Ø52 x 192mm, fritstående med soft underlag

- Leveres i slebet matbørstet rustfrit stål (AISI 304)

**EN** Soap dispenser 170ml, Ø52 x 192mm, free standing, with soft washer

- Available in satin stainless steel (AISI 304)

Tegninger · Drawings

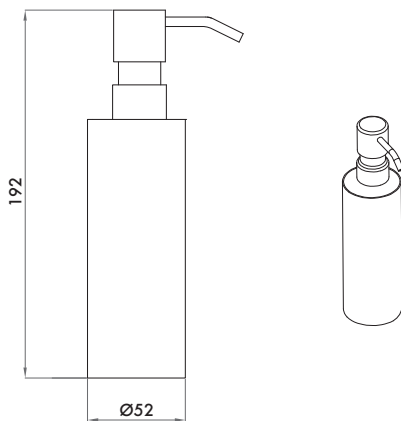

no 7861.00

VVS 775543316



**DK Håndklæde stang cc 600mm**

- Leveres i slebet matbørstet rustfrit stål (AISI 304)
- Leveres incl. skruer og raw plugs

**EN Towel rail, cc 600mm**

- Available in satin stainless steel (AISI 304)
- incl. screws and plugs

**Tegninger · Drawings**

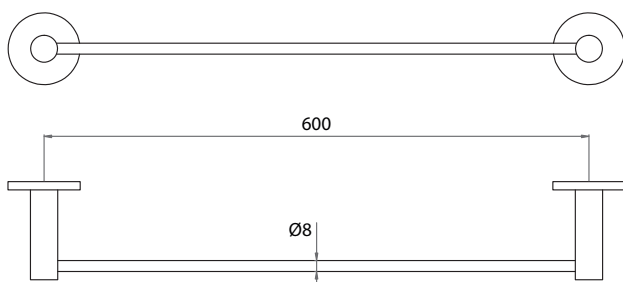



no 7870.00

VVS 778591116

**DK Toiletbørste, til vægmontage**

- Leveres i slebet matbørstet rustfrit stål (AISI 304)
- Sort plast indsats i skålen
- incl. skruer og raw plugs

**EN Toilet brush, for wall mounting**

- Available in satin stainless steel (AISI 304)
- Black plastic insert in the cup
- incl. screws and plugs

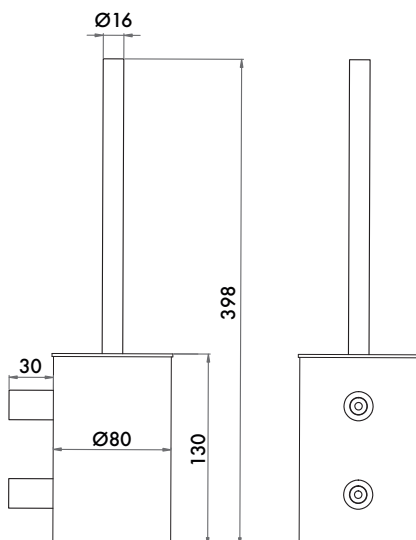
**Tegninger · Drawings**

no 7872.01

VVS 774737116



**DK Sæbedispenser 170ml, Ø52 x 192mm, til vægmontage**

- Leveres i slebet matbørstet rustfrit stål (AISI 304)
- incl. skruer og raw plugs

**EN Soap dispenser 170ml, Ø52 x 192mm, for wall mounting**

- Available in satin stainless steel (AISI 304)
- incl. screws and plugs

**Tegninger · Drawings**

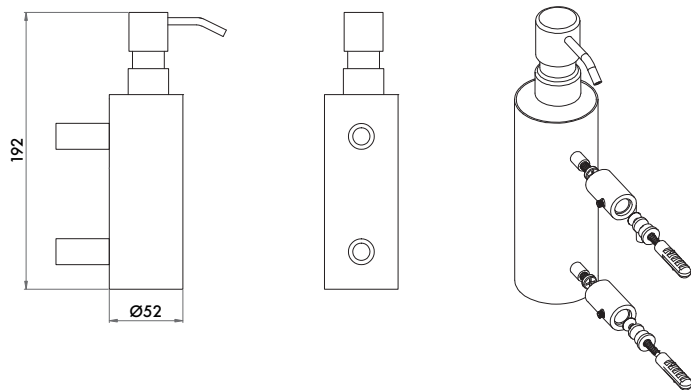

no 7872.02

VVS 774737316

**DK Sæbedispenser 370ml, Ø80 x 200mm, til vægmontage**

- Leveres i slebet matbørstet rustfrit stål (AISI 304)
- incl. skruer og raw plugs

**EN Soap dispenser 370ml, Ø80 x 200mm, for wall mounting**

- Available in satin stainless steel (AISI 304)
- incl. screws and plugs

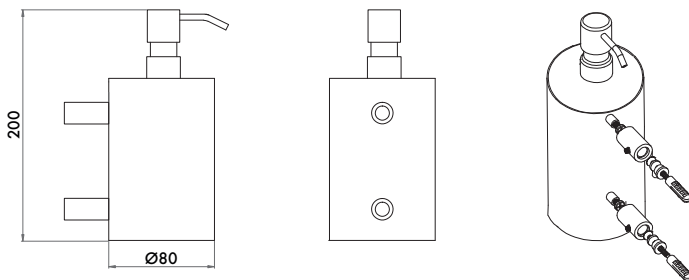
**Tegninger · Drawings**

no 7875.00

VVS 776585116

**DK Reserverulleholder Ø16 x 201mm**

- Leveres i slebet matbørstet rustfrit stål (AISI 304)
- incl. skruer og raw plugs

**EN Spare roll holder Ø16 x 201mm**

- Available in satin stainless steel (AISI 304)
- incl. screws and plugs

## Tegninger · Drawings

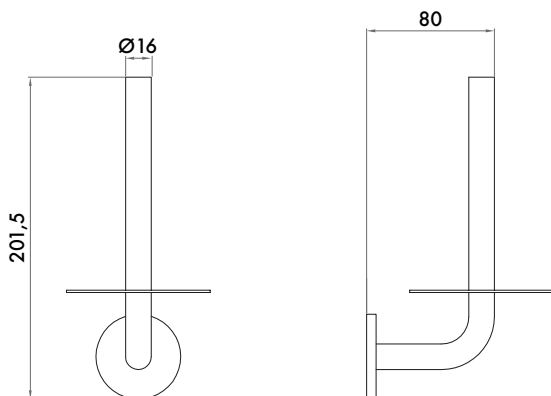

no 7876.00

VVS 776330116

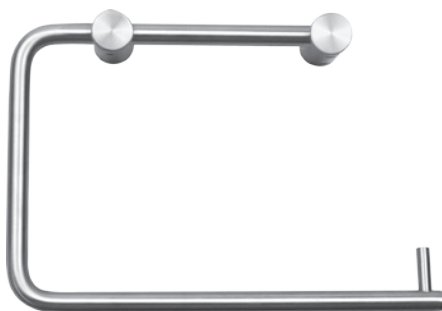

**DK Toiletrulleholder Ø8 x 105 x 155mm**

- Leveres i slebet matbørstet rustfrit stål (AISI 304)
- incl. skruer og raw plugs

**EN Toilet roll holder Ø8 x 105 x 155mm**

- Available in satin stainless steel (AISI 304)
- incl. screws and plugs

Tegninger · Drawings

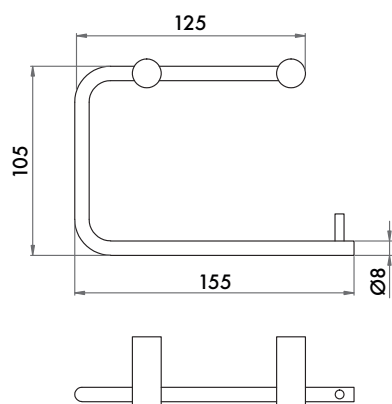

no 7876.001

VVS 776330816

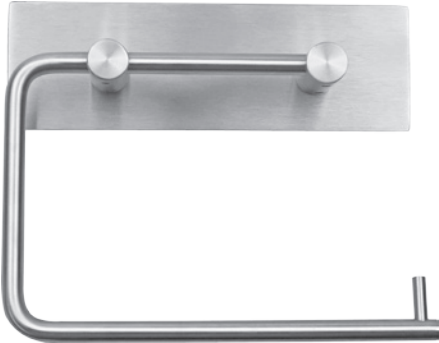
**DK Bagplade for toiletrulleholder 50 x 155 mm**

- Leveres i slebet matbørstet rustfrit stål (AISI 304)

**EN Back plate for toilet roll holder 50 x 155 mm**

- Available in satin stainless steel (AISI 304)

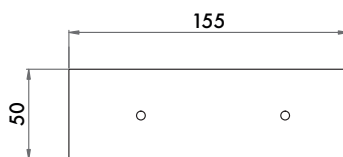
**Tegninger · Drawings**

---

no 7876.01

---

VVS 776329116



**DK Maxi toiletrulleholder 125mm x Ø300mm**

- Leveres i slebet matbørstet rustfrit stål (AISI 304)
- incl. skruer og raw plugs

**EN Maxi toilet roll holder 125mm x Ø300mm**

- Available in satin stainless steel (AISI 304)
- incl. screws and plugs

---

**Tegninger · Drawings**

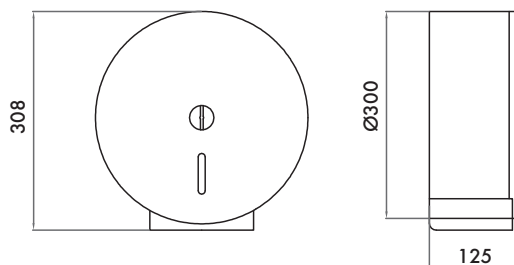

no 7880.00

VVS 775273216

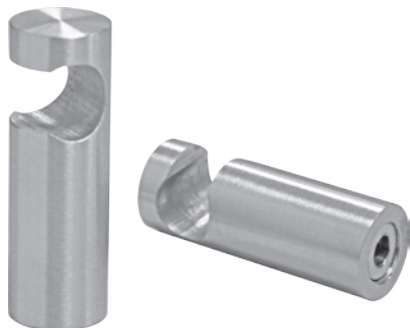

**DK Klædekrog med not  $\varnothing 14$  x 40mm**

- Leveres i sæt a 2 stk
- Leveres i slebet matbørstet rustfrit stål (AISI 304)
- incl. skruer og raw plugs

**EN Coat hook with slot  $\varnothing 14$  x 40mm**

- Set of 2 pcs
- Available in satin stainless steel (AISI 304)
- incl. screws and plugs

Tegninger · Drawings

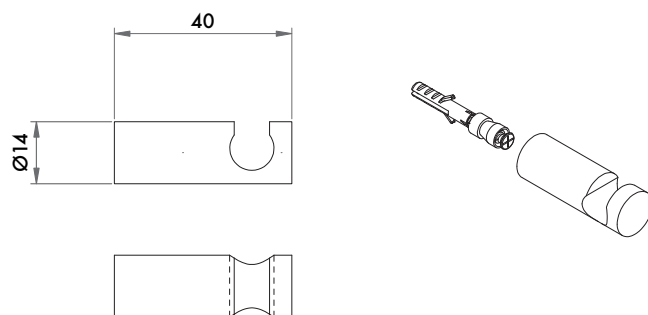



no 7882.00

VVS 775273616

**DK Klædekrogs stang med 3 kroge cc 196mm**

- Leveres i slebet matbørstet rustfrit stål (AISI 304)
- incl. skruer og raw plugs

**EN Hook rail with 3 pins cc 196mm**

- Available in satin stainless steel (AISI 304)
- incl. screws and plugs

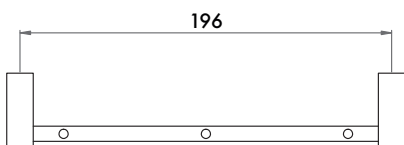
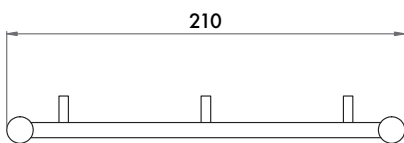
**Tegninger · Drawings**

no 7885.00

VVS 775273316

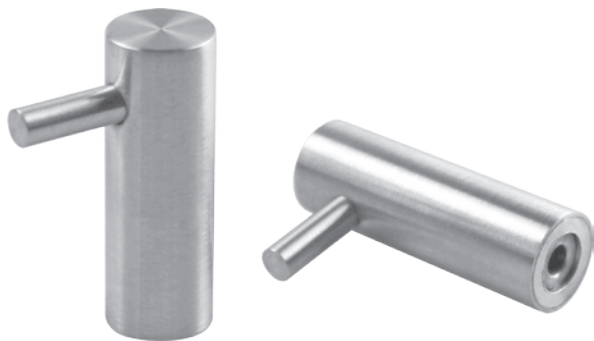

**DK Klædekrog med pind Ø14 x 40mm**

- Leveres i sæt a 2 stk
- Leveres i slebet matbørstet rustfrit stål (AISI 304)
- incl. skruer og raw plugs

**EN Coat hook with pin Ø14 x 40mm**

- Set of 2 pcs
- Available in satin stainless steel (AISI 304)
- incl. screws and plugs

Tegninger · Drawings

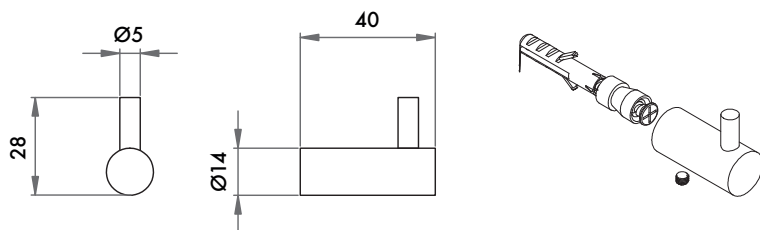

no 88572

VVS 778591816

**DK Toiletbørste hoved**

· Sort

**EN Toilet brush head**

· Black

Tegninger · Drawings

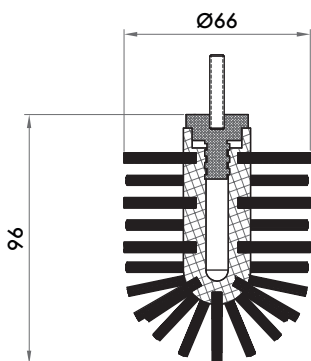

**1. ANVENDELSE**

1. Nærværende almindelige salgs- og leveringsbetingelser (januar 2017) for Randi A/S er gældende for ethvert salg fra Randi A/S, medmindre de udtrykkeligt er fraveget eller modificeret ved anden skriftlig aftale.

1.2 Specielle købsbetingelser eller specifikke krav til det købte fra købers side, anført i f.eks. købers ordreafgivelse eller i købers indkøbsbetingelser, er ikke bindende for Randi A/S, medmindre Randi A/S udtrykkeligt skriftligt har erklæret sig indforstået med vilkårene.

**2. ORDREN**

2.1 I det omfang, at Randi A/S afgiver tilbud, må tilbudsmotageren selv kontrollere, om tilbuddet svarer til behovet med hensyn til mængde og specifikationer.

2.3 I det omfang, Randi A/S fremsender skriftlig ordrebekræftelse, anses aftalen mellem Randi A/S og køber først for at være bindende for Randi A/S på dette tidspunkt, uanset om Randi A/S forinden har fremsendt tilbud, der efterfølgende er accepteret af køber.

2.4 Købers eventuelle indsigelser mod en eventuel ordrebekræftelses indhold skal foreligge skriftligt og være Randi A/S i hænde senest 8 dage efter datoen for ordrebekræftelsen, dog senest ved leverance.

2.5 Købers annullering, returnering eller ændring af en ordre kan kun ske med Randi's skriftlige samtykke. Såfremt en sådan skriftlig samtykke vedrørende returnering foreligger, er køber forpligtet til at levere de pågældende varer franko hos Randi, Mirabellevej 3, 8930 Randers NØ, vedlagt følgeseddel med påført fakturadato og -nummer. Til dækning af ekspeditionsomkostninger beregnes 30% af fakturaprisen for de pågældende varer, dog minimum kr. 100, hvortil kommer tillæg for evt. oppudsning og lignende.

**3. LEVERING**

3.1 Leveringsklausulen er Ex Works, Randers, (INCOTERMS 2000), medmindre andet er aftalt skriftligt i det konkrete tilfælde. Såfremt dette er tilfældet, vil den pågældende leveringsklausul skulle forstås i henhold til INCOTERMS (2000) i det omfang, at dette er muligt.

3.2 Medmindre der udtrykkeligt fremgår andet af ordrebekræftelsen, er det angivne leveringstidspunkt omtrentligt. Randi kan kræve leveringstiden udskudt ved enhver ændring i eller tilføjelse til købsorden.

3.3 Den af Randi meddelte leveringstid forudsætter, at køber rettidigt har opfyldt alle nødvendige eller aftalte formaliteter eller vilkår.

3.4 Randi A/S forbeholder sig retten til at levere i rater.

**4. FORSINKELSE**

4.1 Såfremt Randi A/S ikke leverer i overensstemmelse med det til køber aftalte leveringstidspunkt eller inden rimelig tid herefter, og uden at der foreligger en force majeure-situation, jf. pkt. 10, er køber berettiget til ved skriftlig meddelelse til Randi A/S at kræve levering og fastsætte en endelig frist på minimum 30 arbejdsdage regnet fra det tidspunkt, hvor køber gør denne ret gældende. Såfremt levering ikke sker inden for den af køber fastsatte frist, er køber berettiget til at hæve aftalen, såfremt levering ikke finder sted inden yderligere 10 arbejdsdage efter, at påkrav herom er fremsat.

4.2 Udover den i pkt. 4.1 aftalte hævebeføjelse kan køber ikke gøre andre misligholdelsesbeføjelser ved forsinkelse gældende overfor Randi A/S og kan derfor eksempelvis ikke rejse krav om erstatning af nogen art. Køber har således ej heller mulighed for at hæve tidligere eller efterfølgende salgsaftaler i tilfælde af forsinkelse på en leverance.

**5. BETALING**

5.1 Medmindre andet er aftalt, er betalingsbetingelsen netto kontant.

5.2 Såfremt betaling ikke finder sted rettidigt, tilskrives moranter fra fakturadatoen af det til enhver tid skyldige beløb inklusive tidligere tilskrevne renter, omkostninger m.v. med 1,5% pr. påbegyndt måned.

5.3 Overholder køber ikke de aftalte betalingsbetingelser for en eller flere leverancer, eller misligholder køber på anden måde en købsaftale med Randi A/S, herunder standser sine betalinger, har Randi A/S udover sin øvrige misligholdelsesbeføjelser ret til øjeblikkeligt at standse yderligere leverancer, og Randi A/S's fulde tilgodehavende forfalder straks til betaling.

5.4 Køber er uberettiget til at tilbageholde nogen del af købesummen som sikkerhed for opfyldelse af eventuelle modkrav vedrørende andre leverancer, og sådan tilbageholdelse vil være at betragte som væsentlig misligholdelse af indgåede købsaftaler.

**6. EJENDOMSFORBEHOLD**

6.1 Randi A/S forbeholder sig ejendomsretten til enhver leverance indtil betaling er sket.

**7. VEJLEDNINGER, BROCHURER M.V.**

7.1 Oplysninger, data m.v. givet af Randi A/S i kataloger, brochurer og andet trykmateriale er vejledende og alene bindende for Randi A/S, såfremt købsaftalen konkret henviser til sådanne oplysninger eller data.

7.2 Køber har det fulde ansvar for udvælgelsen af det købte og for, at det købte kan opnå de for køberen forventede resultater, samt det købte kan fungere i købers påtænkte driftsmiljø.

**8. MANGLER**

8.1 Køber skal undersøge det købte for mangler straks ved modtagelsen.

8.2 Ved købers konstatering af mangler skal køber omgående skriftligt overfor Randi A/S beskrive og specificere den påberåbte mangel. Enhver reklamation over mangler, der er eller burde være opdaget ved køberens kontrol af det købte, skal være modtaget af Randi A/S uden ugrundet ophold efter levering af det købte, dog senest i tilstrækkelig tid før det købtes brug, således at Randi A/S forinden kan nå at tage stilling til reklamationen. Overholder køber ikke førnævnte reklamationsregler, kan køber ikke påberåbe sig manglen.

8.3 Ethvert mangelskrav, uanset art, skal være gjort gældende inden for de reklamationsfrister, som fremgår af nærværende pkt. 8. Unnlader køber dette, kan køber ikke efterfølgende påberåbe sig manglen.

8.4 Køber er forpligtet til nøje at iagttage de i Randi A/S's brochure- og produktmateriale eller i korrespondance indeholdte anvisninger eller mundtligt angivne oplysninger om valg, anvendelse og vedligeholdelse af det købte.

8.5 Såfremt der påvises mangler, der kan gøres gældende overfor Randi A/S, er Randi A/S efter eget valg berettiget og forpligtet til enten at foretage omlevering, afhjælpe manglen eller acceptere at give køber et forholdsmæssigt afslag i den aftalte købesum. Køber er herved fuldt og endeligt fyldestgjort for ethvert krav som følger af manglen.

- 8.6 Randi A/S afgiver inden rimelig tid efter modtagelsen af en berettiget reklamation erklæring om sit valg ifølge pkt. 8.5. Såfremt Randi A/S ikke inden 10 arbejdsdage efter afgivelse af sin erklæring til køber opfylder sine forpligtelser i henhold til pkt. 8.5, kan køber skriftligt give Randi A/S en sidste rimelig frist for afhjælpning af manglen. Er Randi A/S's forpligtelse ikke opfyldt inden udløbet af den fastsatte frist, kan køber hæve aftalen, såfremt manglen er væsentlig, eller, hvis manglen må siges at være uvæsentlig, kræve et forholdsmæssigt afslag i den aftalte købesum.
- 8.7 Randi A/S har, udover hvad der ovenfor er bestemt, intet ansvar for mangler, og køber kan derfor ikke gøre andre misligholdelsesbeføjelser gældende, end hvad der fremgår af ovenstående. Randi A/S hæfter således ikke under nogen omstændigheder, uanset eventuel grov uagtsomhed, eksempelvis for direkte tab eller driftstab, avancetab eller andre indirekte tab eller følgeskader, herunder for omkostninger forbundet med afmontering og indmontering.
- 8.8 Det forhold, at Randi A/S måtte opstarte drøftelser eller forhandlinger om en mindelig løsning af en reklamation, medfører ikke, at Randi A/S ikke efterfølgende kan påberåbe sig ansvarsbegrænsningerne i nærværende salgs- og leveringsbetingelser, og at der er sket for sen reklamation.
- 8.9 Det i nærværende pkt. 8 anførte, herunder med hensyn til begrænsningen af Randi A/S's ansvar, finder ligeledes anvendelse, såfremt det købte er behæftet med en retlig mangel, herunder eksempelvis såfremt det købte kræver en immaterialret tilhørende tredjemand eller er i strid med en offentlig-retlig forskrift eller ikke opfylder en sådan, f.eks. et CE-mærkningsdirektiv.
- 9. REKLAMATIONSPERIODE**
- 9.1 Randi A/S accepterer, at reklamationsperioden udvides fra 1 år, og således at den absolutte reklamationsfrist udløber 5 år efter afleveringen af det byggeri, hvori det købte indgår, dog højst 6 år fra overgivelsen af det købte til køberen.
- 10. FORCE MAJEURE OG LIGNENDE BEGIVENHEDER**
- 10.1 Randi A/S hæfter ikke for manglende opfyldelse af sine forpligtelser, som følge af omstændigheder, som ligger udenfor Randi A/S's direkte kontrol (f.eks., men ikke begrænset hertil, strejke, arbejdsnedlæggelse, blokade, lockout, forsinket eller mangelfulde eller væsentligt fordyrede leverancer fra Randi A/S's leverandører, forhindret tilførsel/levering af råstoffer, hjælpestoffer eller nogen anden leverance af tilfredsstillende kvalitet, brand, naturforhold, mangel på transportmiddel eller transportuheld, restriktioner vedrørende import/eksport samt driftsforstyrrelser eller standsning i øvrigt og lignende), som er egnet til at forsinke eller hindre fremstilling eller levering af det købte, eller som gør opfyldelsen væsentligt mere byrdefuld for Randi A/S end forventet.
- 10.2 Såfremt mangelfri eller rettidig levering hindres midlertidigt på grund af force majeure som nævnt i pkt. 10.1, suspenderes leveringsforpligtelsen i det tidsrum, forhindringen varer, og den således udskudte leveringstid anses i enhver henseende for rettidig, hvorfor køber er uberettiget til at hæve købet, så længe der foreligger en sådan begivenhed.
- 10.3 Såfremt Randi A/S vil påberåbe sig nærværende pkt. 10, er Randi A/S forpligtet til straks at give køber meddelelse herom med angivelse af årsag og den tid, forhindringen antages at vare. Randi A/S skal samtidig bestræbe sig på at overvinde hindringen hurtigst muligt og efterfølgende opfylde sine kontraktlige forpligtelser snarest muligt.
- 10.4 Såfremt en force majeure-situation varer eller af Randi A/S påregnes at vare udover 30 arbejdsdage, er såvel Randi A/S som køber berettiget til at hæve den indgåede aftale, uden at dette anses for misligholdelse. Køber kan derfor ikke kræve nogen form for erstatning fra Randi A/S i en sådan situation.
- 11. PRODUKTANSVAR**
- 11.1 Randi A/S er ikke ansvarlig for skader forvoldt af det købte, medmindre skaden skyldes forsæt eller grov uagtsomhed fra Randi A/S's side, eller der er tale om en personskade eller en forbrugertingskade. Uanset førnævnte er Randi A/S dog ikke i noget tilfælde ansvarlig for formuetab, driftstab, tidstab, avancetab, følgeskader eller andet indirekte tab, herunder, men ikke begrænset til tab som følge af købers retsforhold over for tredjemand.
- 11.2 Køber er forpligtet til uden ugrundet ophold skriftligt at meddele Randi A/S, såfremt køber bliver bekendt med, at der er indtrådt, eller at tredjemand påstår, at der er opstået en skade forårsaget af det købte, eller at der er fare for, at der vil indtræde en sådan skade.
- 11.3 I den udstrækning Randi A/S måtte blive pålagt ansvar overfor tredjemand, er køber forpligtet til at holde Randi A/S skadesløs i samme omfang, som Randi A/S's ansvar er begrænset i henhold til nærværende pkt. 11.
- 12. JURISDIKTION OG LOVVALG**
- 12.1 Enhver tvist, som udspringer af nærværende salgs- og leveringsbetingelser, skal afgøres efter dansk ret, dog eksklusive reglerne i den internationale købelov (CISG).
- 12.2 Enhver tvist skal afgøres ved retten i Randers som værneting i første instans. Førnævnte gælder dog ikke i situationer, hvor Randi A/S i en særskilt indgået byggeleveranceklausul har accepteret, at tvister skal behandles af Voldgiftsretten for Bygge- og Anlægsvirksomhed. Køber er endvidere forpligtet, uanset førnævnte, til, såfremt Randi A/S måtte forlange det, at lade sig sagsøge ved samme forum, som behandler et påstået produktansvarskrav rejst mod Randi A/S.

**1. APPLICATION**

1. These general terms and conditions of sale (January 2017) for Randi A/S (hereinafter referred to as "Randi") shall apply to any sale made by Randi, save where expressly departed from or amended by other written agreement.
- 1.2 Any special terms of purchase or specific requirements set by the Buyer concerning the goods purchased, stated for instance in the Buyer's order or set out in the Buyer's general terms and conditions of purchase, shall not be binding on Randi unless Randi has expressly accepted such terms and requirements in writing..

**2. ORDERS**

- 2.1 Where Randi makes an offer, the receiver of such offer shall himself check whether the offer corresponds to his requirements in respect of quantity and specifications.
- 2.3 Where Randi sends a written order confirmation, the agreement between Randi and the Buyer shall not be deemed to be binding on Randi until this day irrespective of whether Randi prior to this day has sent an offer which was subsequently accepted by the Buyer.
- 2.4 Any objections which the Buyer may have to the contents of any order confirmation shall be made in writing and shall be received by Randi no later than 8 days after the date of the order confirmation, although not later than on delivery.
- 2.5 The Buyer's cancellation, return or change of an order shall require the written consent of Randi. Where Randi has given its written consent concerning the return of any goods, the Buyer shall deliver the goods in question carriage paid to Randi A/S, Mirabellevej 3, DK-8930 Randers NØ, Denmark accompanied by a delivery note indicating date and number of invoice. In settlement of the service charges there is a charge of 30 per cent of the invoice price of the goods in question, although not less than DKK 100, with the addition of charges for refurbishing or the like.

**3. DELIVERY**

- 3.1 The term of delivery shall be Ex Works, Randers, Denmark, (INCOTERMS 2000), unless otherwise agreed in writing in the individual case. Where this is the case, such term of delivery shall be construed in accordance with INCOTERMS (2000) to the extent possible.
- 3.2 Unless it expressly appears otherwise from the order confirmation, the time of delivery set out shall be the approximate time. Randi may require that the time of delivery be postponed on any alteration of or addition to the order for purchase.
- 3.3 The time of delivery set forth by Randi implies that the Buyer has met all necessary or agreed formalities or terms on time.
- 3.4 Randi reserves the right to deliver by instalments.

**4. DELAY**

- 4.1 In case Randi does not deliver in compliance with the time of delivery agreed with the Buyer or within reasonable time thereafter, and without this delay being caused by force majeure, cf. clause 10 hereof, the Buyer shall by written notice to Randi be entitled to demand delivery and to fix a final time-limit of not less than 30 working days from the time when the Buyer asserts this right. If delivery does not take place within the time limit fixed by the Buyer, the Buyer shall be entitled to terminate the agreement if the delivery has not taken place within another 10 working days following the claim to this effect.
- 4.2 Apart from the agreed right of termination under clause 4.1, the Buyer shall have no remedies for breach of contract against Randi in case of delays and has thus no right to claim damages of any kind. Consequently, the Buyer shall not be entitled to terminate any previous or succeeding sales agreements either in case of any delays in delivery.

**5. PAYMENT**

- 5.1 Unless otherwise agreed, the terms of payment shall be net cash.
- 5.2 In case of late payment, default interest of the amount due from time to time, including interest previously accrued, costs etc. shall be charged as from the invoice date at the rate of 1.5 per cent per month or fraction of a month.
- 5.3 If the Buyer does not comply with the terms of payment agreed for one or more deliveries, or if the Buyer is otherwise in breach of a purchase agreement with Randi, including suspends his payments, Randi shall in addition to its other remedies for breach of contract be entitled to immediately discontinue any additional deliveries, and the whole amount owed to Randi shall fall due forthwith.
- 5.4 The Buyer shall not be entitled to retain any part of the purchase price as security for fulfillment of any counterclaims concerning other supplies, and such retention shall be deemed to constitute a material breach of any purchase agreements made..

**6. RETENTION OF TITLE**

- 6.1 Randi reserves the right to retain title of any deliveries until payment is made.

**7. DIRECTIONS, BROCHURES ETC.**

- 7.1 Any information, data etc. provided by Randi in its catalogues, brochures and other printed material shall be directional and solely binding on Randi where the purchase agreement specifically refers to such information or data.
- 7.2 The Buyer shall be fully responsible for the selection of the goods purchased and for the goods purchased achieving the projected results and for the working of the goods purchased in the Buyer's contemplated working environment.

**8. DEFECTS**

- 8.1 On receipt the Buyer shall examine the goods purchased in order to ascertain any defects.
- 8.2 Where the Buyer finds any defects, the Buyer shall forthwith notify Randi in writing, describing and specifying the claimed defect. Any complaints about defects which were or should have been established at the Buyer's examination of the goods purchased shall be received by Randi without undue delay after delivery of the goods purchased, and not later than within reasonable time before the goods purchased are put into operation so that Randi prior to this has the time to consider the complaint. If the Buyer does not comply with the above provisions on complaints, the Buyer may not rely on the defect.
- 8.3 Any claim for defects, whatsoever the nature of such, shall be made within the time limits for complaints set out in clause 8 hereof. If the Buyer fails this, the Buyer cannot subsequently claim the defect.
- 8.4 The Buyer shall strictly comply with the directions stated in Randi's brochures, product description material or correspondence or any information on selection, use and maintenance of the goods purchased provided verbally.
- 8.5 Where defects for which claims can be made against Randi are established, Randi shall be obliged at its own discretion either to replace the defective goods, remedy the defect or accept to grant the Buyer a pro rata reduction in the agreed purchase price, whereby any claim made by the Buyer as a result of the defect shall be fully and conclusively satisfied.

- 8.6 Within reasonable time after receipt of any legitimate complaint, Randi shall make a statement as to its chosen option according to clause 8.5. If Randi does not within 10 working days following such statement fulfil its obligations under clause 8.5 towards the Buyer, the Buyer may in writing grant Randi a final and reasonable time limit for remedy of the defect. If Randi's obligation has not been fulfilled before expiry of the time limit fixed, the Buyer may terminate the agreement provided it is a material defect or, if the defect is considered immaterial, demand a pro rata reduction in the agreed purchase price.
- 8.7 Apart from what has been agreed in the above provisions, Randi shall not be liable for defects. Consequently, the Buyer shall have no other remedies for breach of contract than those set out above. Accordingly, Randi shall under no circumstances, whether caused by gross negligence or not, be liable for e.g. direct loss or loss on operations, loss of profits or other indirect loss or consequential damage, including for costs incidental to dismantling or installation.
- 8.8 The circumstance that Randi may initiate discussions about or negotiations for an amicable settlement shall not imply that Randi cannot subsequently rely on the limitations of liability set forth in these terms and conditions of sale, nor that the complaint was made too late.
- 8.9 The provisions under clause 8 hereof, including the provisions on limitation of Randi's liability, shall also apply in case the goods purchased were defective according to law, including e.g. in case the goods purchased infringe an intellectual property right owned by a third party or are contrary to any directions governed by public law or do not comply with such directions, e.g. a directive on CE-marking.
- 9. TERM FOR MAKING COMPLAINTS**
- 9.1 Randi accepts that the term for making complaints is prolonged from 1 year so that the absolute deadline for making complaints expires 5 years after the handing-over of the property of which the goods purchased form part, and not later than 6 years after delivery of the goods purchased to the Buyer.
- 10. FORCE MAJEURE AND SIMILAR EVENTS**
- 10.1 Randi shall not be liable for non-performance of its contractual obligations caused by events beyond the direct control of Randi (e.g., but not limited to, strikes, walk-outs, blockade, lockout, late or defective delivery or supplies which have undergone considerable price increases from Randi's suppliers, obstruction of supply / delivery of raw materials, intermediary products or any other delivery of a satisfactory quality, fire, acts of God, lack of transport or transport accidents, restrictions imposed on import/export and interruption of operations or other stoppage etc.), which may delay or obstruct the manufacture or delivery of the goods purchased or which may make performance considerably more onerous to Randi than expected.
- 10.2 In case non-defective delivery or delivery on time is prevented temporarily due to force majeure as set out in clause 10.1, the delivery obligation shall be suspended in the period in which the obstruction lasts, and the postponed delivery time as a result thereof shall in all respects be deemed on time. Accordingly, the Buyer shall not be entitled to cancel the purchase as long as such event prevails.
- 10.3 Where Randi wants to rely on clause 10 hereof, Randi shall forthwith notify the Buyer thereof, indicating the cause and the timespan in which the obstruction is expected to last. At the same time Randi shall make an effort to overcome the obstruction as soon as possible and subsequently fulfil its contractual obligations.
- 10.4 If the force majeure event exceeds or is expected by Randi to exceed 30 working days, both Randi and the Buyer shall be entitled to terminate the agreement entered into without this being deemed breach of contract. Consequently, the Buyer may not claim any kind of damages against Randi in such event.
- 11. PRODUCT LIABILITY**
- 11.1 Randi shall not be liable for any damage caused by the goods purchased, unless such damage is caused by intent or gross negligence on the part of Randi or such damage is a personal injury or damage to consumer goods. Notwithstanding the above, Randi shall not in any case, however, be liable for financial loss, loss on operations, loss of time, loss of profits, consequential damage or other indirect loss, including, but not limited to, loss as a result of the Buyer's legal relations with any third party.
- 11.2 The Buyer shall without undue delay notify Randi in writing if the Buyer receives information to the effect that damage has occurred, or a third party claims that damage has been caused by the goods purchased or that there is a risk that such damage will occur.
- 11.3 In case Randi incurs liability against any third party, the Buyer shall indemnify Randi to the same extent as Randi's liability is limited according to clause 11 hereof.
- 12. APPLICABLE LAW AND VENUE**
- 12.1 Any dispute arising out of or in connection with these Terms and Conditions of Sale shall be governed by Danish law, excluding; however, the rules laid down in CISG.
- 12.2 Any dispute arising out of or in connection with these Terms and Conditions of Sale shall be submitted to and be subject to the jurisdiction of the Court of Randers as the court of first instance. However, the above shall not apply where Randi has separately entered into a clause on construction work and thereby accepted that any disputes shall be subject to the jurisdiction of the Danish Building and Construction Arbitration Court. Furthermore, where so required by Randi, the Buyer shall, notwithstanding the above, allow an action being brought against him before the same forum as the one hearing any alleged product liability claim made against Randi.





