

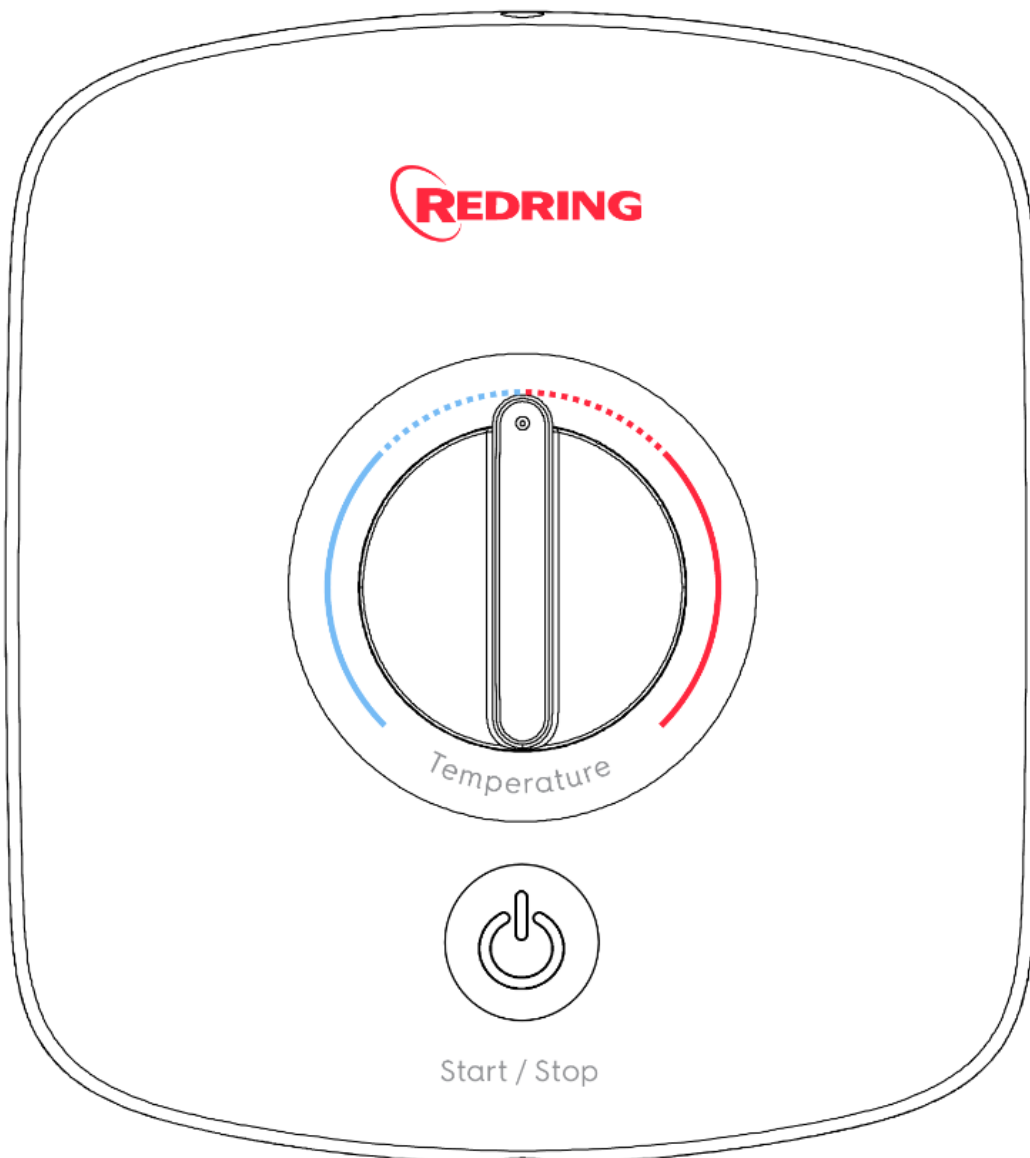

## Manual Handwash RMHW3



**IMPORTANT:**  
This booklet should be left with the user after  
installation and demonstration.

***THIS APPLIANCE CAN BE USED BY CHILDREN AGED FROM 3 YEARS AND ABOVE AND PERSONS WITH REDUCED PHYSICAL, SENSORY OR MENTAL CAPABILITIES, OR LACK OF EXPERIENCE AND KNOWLEDGE IF THEY HAVE BEEN GIVEN SUPERVISION OR INSTRUCTION CONCERNING USE OF THE APPLIANCE IN A SAFE WAY AND UNDERSTAND THE HAZARDS INVOLVED.***

***CHILDREN SHALL NOT PLAY WITH THE APPLIANCE.***

***CLEANING AND USER MAINTENANCE SHALL NOT BE MADE BY CHILDREN DO NOT SWITCH THE APPLIANCE ON IF YOU SUSPECT THE APPLIANCE OF BEING FROZEN. WAIT UNTIL YOU ARE SURE IT HAS THAWED OUT.***

## ***Section 1 Important Safety Information***

- Your handwash unit has been designed for convenience, economy and safety of use, provided that it is installed, used and maintained in good working order and in accordance with our instructions and recommendations.
- ***ALL WIRING AND INSTALLATION MUST BE SUPERVISED BY A SUITABLY QUALIFIED PERSON.***
- ***THIS APPLIANCE MUST BE EARTHED.***
- The installation must be in accordance with the current edition of BS.7671 (*the 'IET Wiring Regulations'*) and 'Part P' of the '*Building Regulations'* in force at the time of installation. Installations outside England and Wales must also conform to any local regulations in effect
- This appliance is intended to be permanently connected to the fixed electrical wiring of the mains supply with its own dedicated supply, however it can be connected with a 13amp socket and plug.
- This appliance must ***NOT*** be fitted where it may be subjected to freezing conditions.
- Isolate the mains electrical and water supply before removing the appliance front cover.
- ***DO NOT*** fit any sort of tap or control on the appliance outlet.
- Take care to avoid restricting the outlet of the pressure relief device.

If water is discharged from the pressure relief device, maintenance will be required before the appliance can be safely used.

## ***Section 2 Advice To Users***

The following points will help you have a greater understanding of how your handwash works:

- The electric heating element operates at a constant rate.  
The required water temperature is achieved by adjusting the rate of water flow via the control knob.  
The higher the water flow the lower the temperature and vice versa.  
The temperature of the water supplied from the mains can vary considerably throughout the year from 5 to 20°C.  
This means that in the winter, flow rate will be less than in the summer to achieve the same outlet temperature.
- Your handwash is designed to work within a range of water pressures, if the pressure falls below the minimum pressure required, it is likely that the pressure switch will turn off the power to the heating element, resulting in cold water being produced by the unit.  
(see page 3 for details)

Plan your own installation carefully.  
Check on the nearest and most readily accessible rising mains water supply.

# Section 3

## Handwash Installation

The unit should be sited so that all the spray is contained in the sink.

We recommend that a WRAS (Water Regulations Advisory Scheme) listed isolating valve is fitted into the mains cold water supply for servicing purposes.

### **WARNING:**

**ALL WIRING AND INSTALLATION MUST BE SUPERVISED BY A SUITABLY QUALIFIED PERSON.**

**DO NOT INSTALL THIS UNIT WHERE IT MAY BE SUBJECTED TO FREEZING CONDITIONS.**

**USE ONLY THE COLD RISING WATER MAIN SUPPLY.**

**DO NOT CONNECT THE HANDWASH UNIT TO THE DOWN SERVICE FROM A COLD WATER STORAGE TANK.**

# Section 4 Plumbing Connection

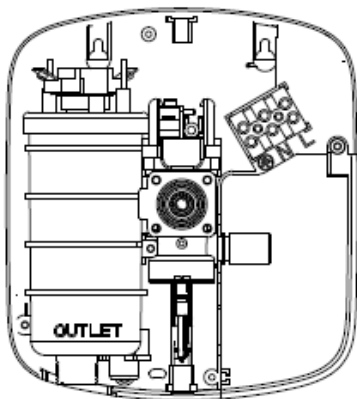

**Plumbing the handwash unit must precede making electrical connections.**

The handwash unit must be connected to the cold water supply with a minimum running

pressure of 69 kPa (0.7 bar, 10 psi) and a maximum pressure of 690 kPa (7.0 bar, 100 psi).

Turn off the water supply at the isolating tap.

Ø15mm copper, chrome polished, stainless steel pipe or plastic pipe with a 15mm compression elbow or push fit. should be used.

Ensure that there are no burrs on the pipe.

1. Before removing the front cover check that the rotary temperature control is set to **fully anticlockwise** or **full flow**
2. Remove the two screws top and bottom securing the handwash unit cover and remove the cover complete.
3. Remove the water inlet cover positioned to the bottom right of the backplate.
4. Place the handwash unit on the wall and determine the entry position of the water inlet supply pipe.

5. Mark the location of the fixing screws through the backplate. Need correct picture

Drill the top two and bottom screw entry points using a 5.5mm drill and insert wall plugs provided.

6. Align the unit to the screw entry points tighten the top screw with head protruding about 10mm from the wall and hook the backplate over the screw head.

This allows for correct and accurate alignment of the handwash unit before fixing the bottom position.

7. Secure the unit to the wall. The slots are elongated to allow for final adjustment.
8. Before completing the connection of the water supply to the inlet of the unit, ensure you flush out the pipework to remove all swarf and system debris.
9. Connect the mains water supply to the inlet of the handwash unit using the relevant Ø15mm pipe, copper pipe, stainless steel or plastic pipe with a 15mm compression elbow or push fit.
10. Check for leaks

**Do not use excessive force when making the connection to the unit.**

**WARNING:**

**TAKE CARE TO AVOID RESTRICTING THE OUTLET OF THE PRESSURE RELIEF DEVICE.**

## ***Section 5 Electrical Connection***

**A means of disconnection in all poles must be incorporated in the fixed wiring in accordance with the wiring rules.**

### ***THIS HANDWASH MUST BE EARTHED.***

The electrical installation must be in accordance with the current BS.7671 (IET Wiring Regulations) and 'Part P' of the Building Regulations and/or local regulations

1. Turn off Electricity at isolation switch.
2. The handwash unit is designed for a single phase AC electrical supply.
3. Use 3-Core 1.5mm<sup>2</sup> double insulated cable. The cable can be surface clipped, hidden or via conduit.
  4. The incoming cable access to the handwash unit is located at the top, bottom or rear of the unit on the right hand side.
5. Cut back cable.
6. Connect cable to terminal block making sure that all the retaining screws are **VERY TIGHT** and that no cable insulation is trapped under the screws.
7. Ensure the cable clamp is used to secure the cable into position.

**WARNING:**

**FAILURE TO COMPLY WITH THESE INSTRUCTIONS COULD RESULT IN FAILURE OF THE TERMINAL BLOCK**

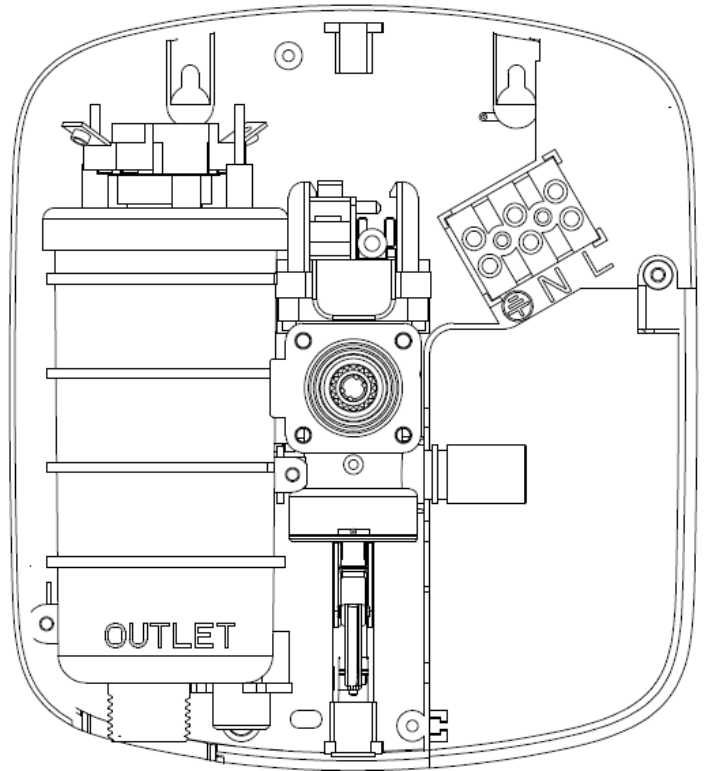

## ***Section 6 Fitting The Swivel Arm Into Position***

**IMPORTANT: Fitting the swivel arm must precede fitting the front cover**

1. Push the swivel arm into the outlet and tighten by turning clockwise until swivel arm is tight.

## ***Section 7 Fitting the Cover into Position***

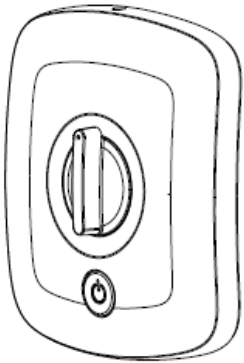

**It is necessary to engage the control knob on the correct position on the valve spindle before the front cover is located.**

1. Before replacing the front cover check that the valve spindle and temperature control knob are set to fully anti clockwise or full flow.
2. Secure the front cover with the two screws.

### **Important information**

Ensure the rotary temperature control is positioned fully anti clockwise and that the valve is fully open.

## ***Section 8 Commissioning Procedure***

1. Switch OFF power to the mains
2. Ensure the water supply is fully on at the mains and the isolating service valve is fully open.
3. Push the start/stop button and water will start to flow.
4. Check that the water flows freely from the handwash within a few seconds
5. Push the start/stop button again to turn the unit off.
6. Check for any leaks.
7. Refit front cover

## ***Section 9 Operating the Handwash***

1. The mains electricity and water supply should normally be left on.
2. Press the start/stop button and water will flow through the heater.
3. Water is heated instantaneously as it flows over the heating elements in the heat exchanger.
4. The flow/temperature is adjusted via the control knob, the higher the flow the lower the temperature and the lower the flow the higher the temperature.

**Wait a few moments for the temperature of the water to stabilise.**

4. If the incoming water pressure falls below a set limit, the pressure switch will operate and switch off the power to the heating element
5. The unit incorporates a pressure relief device to safeguard against abnormal pressure conditions and provides a safeguard should an excessive buildup of pressure occur within the unit.

***DEMONSTRATE OPERATION TO USERS, AND LEAVE THIS BOOK WITH THEM FOR FUTURE REFERENCE.***

### **WARNING:**

***DO NOT SWITCH THE UNIT ON IF YOU SUSPECT IT OF BEING FROZEN. WAIT UNTIL YOU ARE SURE IT HAS THAWED OUT.***

### **WARNING:**

***CONSIDERATION SHOULD BE GIVEN TO SUPERVISING THE YOUNG, ELDERLY AND THE INFIRM WHILST THEY USE THIS UNIT.***

# ***Section 10 Routine Maintenance***

1. We recommend that the electrical isolator is switched off during maintenance to stop the unit being switched on accidentally.
2. The cover should only be cleaned using a soft cloth and that the use of abrasive or solvent cleaning fluid is to be avoided as this can damage the plastic.
3. We recommend the spray arm to be cleaned periodically to remove any lime scale or debris which will reduce the performance of the unit. In hard water areas cleaning may be needed more often than in soft water areas.
4. Scrub the spray plate at the end of the spray arm with a small stiff bristled brush. If the deposits are stubborn remove the central spray rings with the central screw and immerse in a lime scale remover solution.

# ***Section 11 Troubleshooting***

## **1. Water is too hot**

Increase the water flow by turning control dial anti clockwise to increase the flow.

## **2. Water is too cold**

Decrease the water flow by turning the control dial clockwise to decrease the flow

## **3. Water takes too long to heat up**

Thermal cut out has operated after the previous use and will automatically reset.

## **4. Water goes cold while using handwash**

Check the water pressure has not fallen so far that the pressure switch has switched off

## **5. Spray Pattern is poor**

Remove spray plate from the spray arm and de scale.

# ***Section 12 After Sales Service***

Please call our technical team on:

0344 879 3588

Or alternatively email us on:

customer.[services@glendimplex.com](mailto:services@glendimplex.com)

Remember to quote the exact type of handwash, as written on the front of the unit and on this leaflet.

The model and serial number are located on the bottom face of the handwash.

Make a note of those numbers here, and be sure to quote them if you call for advice.

**Model Number:** .....

**Serial Number:** .....

**NOTE:** You may be charged for a service call if you do not have the serial number.

# *Section 13 Energy Related Product Directive (ErP)*

Supplier/Manufacturer	<b>Redring</b>
Product	<b>Manual Handwash</b>
Supplier Model Number	<b>RMHW3</b>
Load Profile	3XS
Efficiency Class	A
Efficiency %	38
Consumption (kwh/annum)	78
Sound (db)	15

# Warranty

## Terms and Conditions for UK (outside UK contact your local distributor)

In the unlikely event of a product breakdown during the warranty period, you should contact our Service and Repair Helpline who will be able to assist with the repair and advise of the best course of action to be taken.

Please **DO NOT** remove the product prior to making this call as this may invalidate your guarantee.

Service and Repair Tel: 03448793588 or email: [customer.services@glendimplex.com](mailto:customer.services@glendimplex.com)

We warranty this product for a period of 12 months from the date of purchase.

Within the warranty period we will resolve, **free of charge**, any manufacturing defects in the product resulting from faulty workmanship or material on condition that:-

- a) The product has been correctly installed and commissioned in accordance with our instructions and is being used on the supply circuit or voltage printed on the rating plate.
- b) The product has been used in accordance with these instructions and has not been tampered with or otherwise subject to misuse, neglect or accident.
- c) The product has not been taken apart, modified or repaired except by a person authorised by us.
- d) Evidence of the date of purchase in the form of an invoice or receipt will be required in order to qualify under the terms of this guarantee.
- e) For the service work to be undertaken free of charge, the work must only be undertaken by Glen Dimplex Limited, or our approved agents.
- f) Service under warranty has no effect on the expiry date.  
The warranty on any exchanged parts or product ends when the original guarantee period ends.

### EXCLUSIONS

This warranty **DOES NOT** cover damage or defects arising from poor or incorrect installation, improper use or lack of maintenance, including the build-up of limescale.

It is the responsibility of the installer to check that the installation parameters meet the requirements of the products, and any relevant regulations.

If we are called out to a fault, which is subsequently identified as being an installation fault, we will make a charge.

It is important that the routine checks are completed before calling us out, as many issues can be simply diagnosed and resolved.

A charge will be made where a call under the terms of the warranty has been booked and a failure was not product related, or an engineer arrives and is not able to gain access.

We make no guarantees as to response time for repairs.

We will endeavour to achieve the most timely response possible but while we indicate an average response time, this should not be taken as a guarantee.

The warranty applies to a repair or replacement (at our discretion) of the product subject to the conditions above, and **DOES NOT** cover compensation for the loss of the product or consequential loss of any kind.

This warranty does not apply to the repair or replacement of pressure relief devices, sprayheads, isolating switches, electrical cable, fuses and/or circuit breakers.

**This Warranty does not affect your statutory rights.**

Millbrook House, Grange Drive,

Hedge End, Southampton, SO30 2DF

Tel: +44 (0) 3448793588

Customer Service Tel: +44 (0) 344 8793588

Customer Service Email: [Customer.services@glendimplex.com](mailto:Customer.services@glendimplex.com)

