

# RS PRO SOLAR GENERATOR

## ASSEMBLY INSTRUCTIONS



# CONTENT

<b>PARTS LIST MECHANICS</b>	<b>3</b>
<b>PARTS LIST ELECTRICAL</b>	<b>4</b>
<b>PARTS LIST WIRING</b>	<b>5</b>
<b>THE MOST IMPORTANT TOOLS REQUIRED</b>	<b>6</b>
<b>CUTTING THE ALUMINUM PROFILES</b>	<b>8</b>
<b>CUTTING THE CLADDING PANELS</b>	<b>9</b>
<b>ASSEMBLY OF THE FRAME</b>	<b>15</b>
<b>INVERTER AND CHARGER</b>	<b>31</b>
<b>ATTACHING SOLAR PANELS TO THE FRAME</b>	<b>33</b>
<b>ASSEMBLY OF PANELS</b>	<b>39</b>
<b>RUBBER PADS</b>	<b>46</b>
<b>WIRING: SOLAR PANELS AND CHARGER</b>	<b>47</b>
<b>WIRING: INDICATOR LIGHTS</b>	<b>48</b>
<b>WIRING: EXTERNAL CHARGER</b>	<b>49</b>
<b>WIRING: ACCESSORIES</b>	<b>50</b>
<b>WIRING: INVERTER 230V</b>	<b>51</b>
<b>INSTALLATION OF THE BATTERY</b>	<b>52</b>
<b>COMMISSIONING</b>	<b>54</b>

# PARTS LIST MECHANICS

RS Code	Description	Pieces
761-3319	9 Aluminum profile 40x40, 8mm groove 14	14
681-665	Plastic sheet, transparent, 6mm x 610mm x 1250mm 2	2
767-5711	Cube connector 18	18
767-5695	Connecting angle 16	16
767-5737	Pivot Joint 6	6
767-5654	T-slot nut M6 66	66
767-5660	T-slot nut M8 14	14
767-5822	M8x20, self-tapping screw 44	44
483-9717	M8x16 Pan-head screw 10	10
483-9650	M6x12 Pan-head screw 6	6
483-9672	M6x16 Pan-head screw 50	50
483-9688	8 M6x20 Pan-head screw 2	2
525-880	M6x25mm Hexagon head screw 4	4
917-2832	2 M6x12mm Hexagon head screw 12	12
560-619	M3x16 Pan-head screw 8	8
666-7766	Washers for M6 screws 15	15
666-7772	Washers for M8 screws 12	12
232-6860	0 Washers for M6 screws, nylon 78	78
525-919	Hexagon nuts M6 18	18
560-293	Hexagon nuts M3 8	8
313-2734	4 Wheels ø 50mm, 50kg 4	4
467-416	DIN rail 3	3
456-490	Plastic handle 3	3
847-3116	Telescopic support 2	2
126-4959	Rubber vibration damper, M6 buffer, Ø 30mm x 10mm 6	6
224-3135	Cable tie 265mm approx. 50	ca. 50

# PARTS LIST ELECTRICAL

RS Code	Description	Pieces
727-0433	12V 120Ah lead-gel battery 1	1
905-4532	Solar charge controller 1	1
904-6125	12V 20W solar panels 4	4
179-3330	240V DC/AC inverter 1	1
549-283	12V battery charger 1	1
233-7809	Voltmeter 1	1
668-8839	Fan 1	1
325-4840	Battery disconnecter 1	1
273-003	Rocker switch, illuminated 4	4
466-150	Disconnect switch 2	2
763-7909	Indicator light, red 2	2
763-7918	Indicator light, green 1	1
111-6748	USB socket 1	1
186-3013	USB extension 1	1
214-4099	Power connector socket blue 2P + E, 230 V / 16A 1	1
214-4166	Power connector socket Blue 2P + E, 200 - 250 V / 16A 1	1
197-2006	Universal housing grey 2	2
325-4840	Battery disconnecter 100A 1	1
174-5456	IEC connector C8 250 V 1	1
134-7319	Insulating tape, PVC black, 0.13mm x 19mm x 33m 1	1















# PARTS LIST WIRING

RS Code	Description	Pieces
811-1467	Single core cable 6 mm <sup>2</sup> , red 1	1
811-1470	Single core cable 6 mm <sup>2</sup> , black 1	1
180-5950	Single core cable 1.5 mm <sup>2</sup> , red 1	1
180-5946	Single core cable 1.5 mm <sup>2</sup> , black 1	1
408-277	Cable conduit, black PET 1	1
134-7319	Insulating tape, PVC black 1	1
178-8670	Ring cable lug, vinyl, yellow, 8.4mm, max. 6mm <sup>2</sup> 6	6
208-2492	Ring cable lug, vinyl, red, 8.4mm, max. 1.5mm <sup>2</sup> 3	3
534-216	Ring cable lug, vinyl, red, 4.16mm, max. 1.5mm <sup>2</sup> 8	8
534-395	Flat receptacle, red, insulated, 4.8 x 0.8mm 12	12
157-1266	Wire end ferrules up to 6mm <sup>2</sup> 3	3
178-7311	Wire end ferrules up to 1.5mm <sup>2</sup> 5	5
311-8003	Wire end ferrules up to 2 x 6mm <sup>2</sup> 6	6
184-9676	Wire end ferrules up to 2 x 1.5mm <sup>2</sup> 12	12
534-288	Cable splice connectors, butt connectors, up to 1.5mm <sup>2</sup> red 6	6
534-266	Forked cable lug up to 1.5mm <sup>2</sup> 8	8
849-6115	Schuko plug, 250 V / 16A 1	1
253-7011	Mains cable white 3 x 0.75 mm <sup>2</sup> 1	1
153-3624	LED strip, red, 5m x 8mm 12V 1	1
153-3643	LED strip, white, 5m x 8mm 12V 1	1
262-4322	Terminal block, grey, 6mm <sup>2</sup> with fuse holder 6	6
262-4346	Terminal block grey, 6mm <sup>2</sup> 4	4
563-778	Vehicle fuse, standard, light brown, 5A 6	6
262-4198	Terminal block, grey, 10mm <sup>2</sup> 7	7
262-4245	End plate for terminal block 3	3
242-0464	End plate for feed-through terminal block 7	7

# THE MOST IMPORTANT REQUIRED TOOLS

RS Code	Description	Image
213-916	RS PRO HSS twist drill 2mm x 49 mm, 10 pieces	
213-821	RS PRO HSS twist drill 4mm x 75 mm, 10 pieces	
214-004	RS PRO HSS twist drill 8mm x 117 mm, 10 pieces	
247-8330	Wood auger bit set 3mm => 10mm, 8-piece	
484-8474	Wood router bit set 10mm =>25mm, 6-piece	
215-934	HSS hole saw, Ø 51mm, drilling depth 32mm	
216-189	HSS hole saw , Ø 60mm, drilling depth 32mm	
216-195	HSS hole saw , Ø 64mm, drilling depth 32mm	
216-404	HSS hole saw , Ø 79mm, drilling depth 32mm	
215-978	Pilot drill arbor, Ø 9.5mm	
192-3719	5 x 5.5 mm open-end wrench, length 110 mm	
192-3692	7 mm combination wrench, length 110 mm	
192-3695	10 mm Combination wrench, length 140 mm	

# THE MOST IMPORTANT REQUIRED TOOLS

RS Code	Description	Image
192-3698	RS PRO, SW 13 mm Combination spanner, double-sided, length 170 mm	
542-3509	RS PRO metric hexagon key set of 15 pieces 1.27 =>10mm L-shaped long, ball end	
789-4590	RS PRO safety knife, snap-off blade, retractable	
192-3657	RS PRO tape measure, 3m metric/imperial	
188-9702	RS PRO Plastic folding rule, metric, 2m	
304-8421	Stop square, 100 mm x 70 mm	
875-5821	RS PRO Insulated screwdriver set, 7-piece slotted, POZIDRIV	
489-2538	Edding permanent marker pen, fine, black, tip	
449-9577	RS PRO Hacksaw 300 mm HSS blade	
494-133	Stanley hand jigsaw 150 mm blades	
122-1790	RS PRO hand crimping pliers for wire end ferrules	
613-044	RS PRO stripping tool, round 0.2 => 6mm, 170 mm	
499-2313	RS PRO hand crimping tool for insulated blade terminals	

# CUTTING THE ALUMINIUM PROFILES TO SIZE

RS Code	Description	Pieces
761-3319	Aluminium profile, slot 8, 40x40x1000m	14

4x	476mm	476mm	
2x	318mm	278mm	278mm
2x	460mm	460mm	
1x	556mm	180mm	180mm
2x	455mm	455mm	
1x	410mm	410mm	
1x	238mm	238mm	238mm
1x	396mm		



# PREPERATION OF THE PANELLING

RS Code	Description	Pieces
681-665	6mm transparent Polycarbonate sheet, 610x1250mm	2

## BOTTOM PANEL

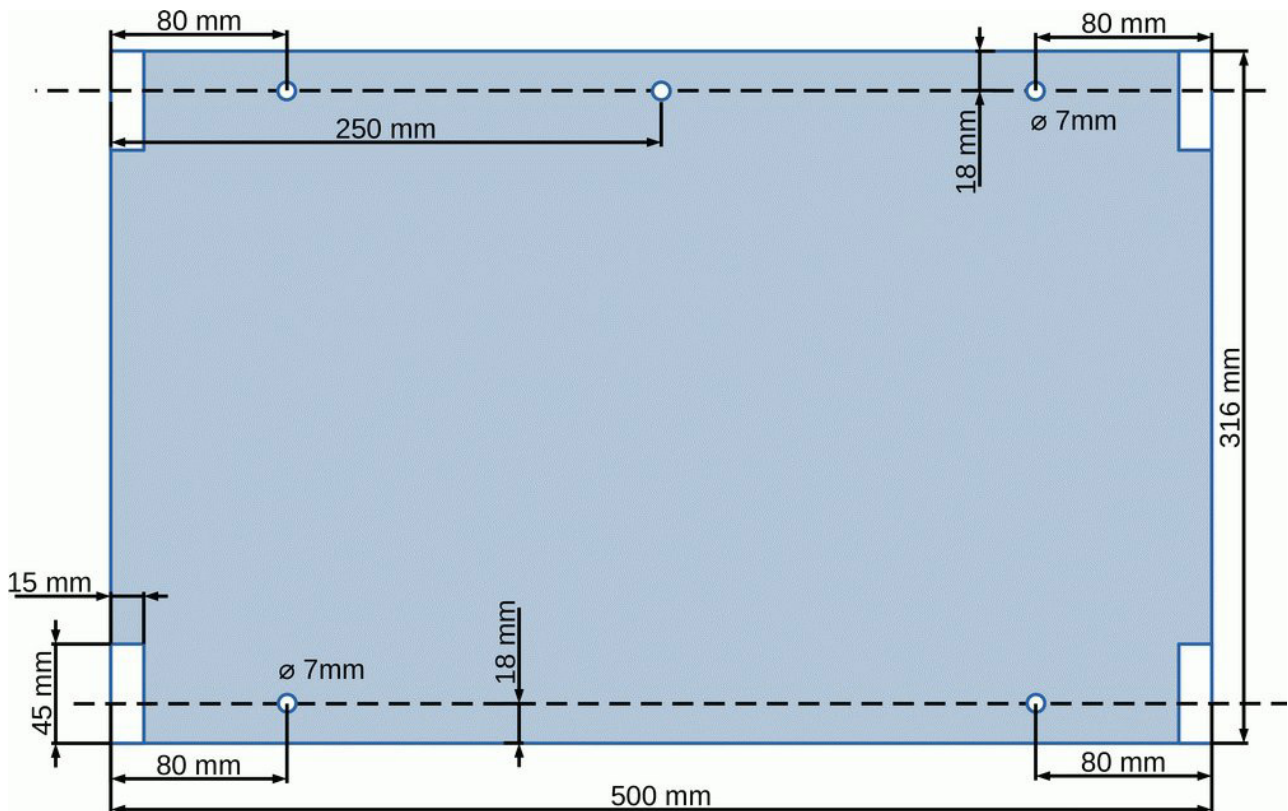

Polycarbonate must not be exposed to strong tension or heat during processing. If you use electric saws, the plastic can melt or crack. The use of a hand saw is recommended. A few drops of water with dish-washing liquid make hand sawing easier.



# PREPERATION OF THE PANELLING

## UPPER PANEL

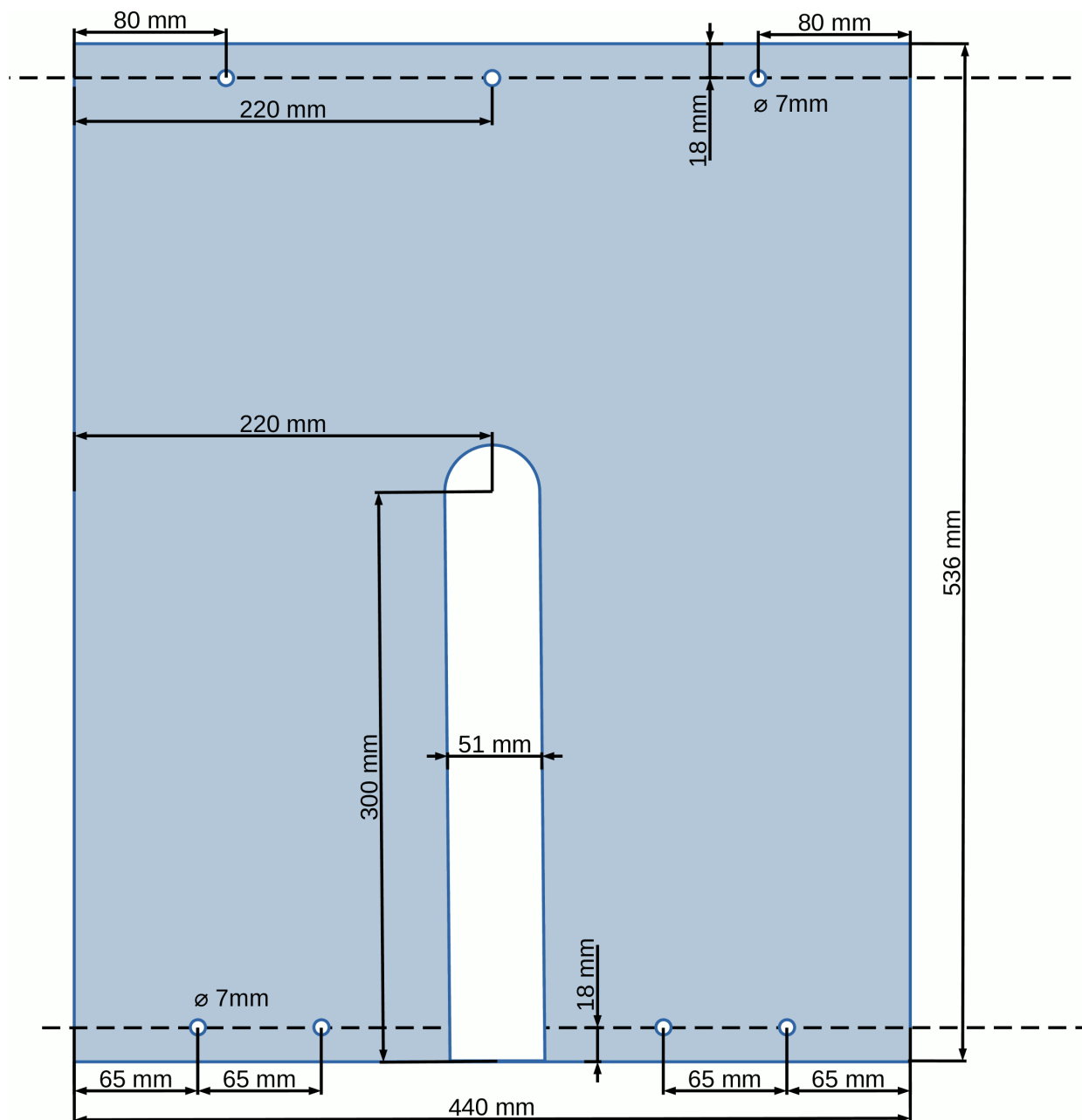



# PREPERATION OF THE PANELLING

## LEFT SIDE PANEL

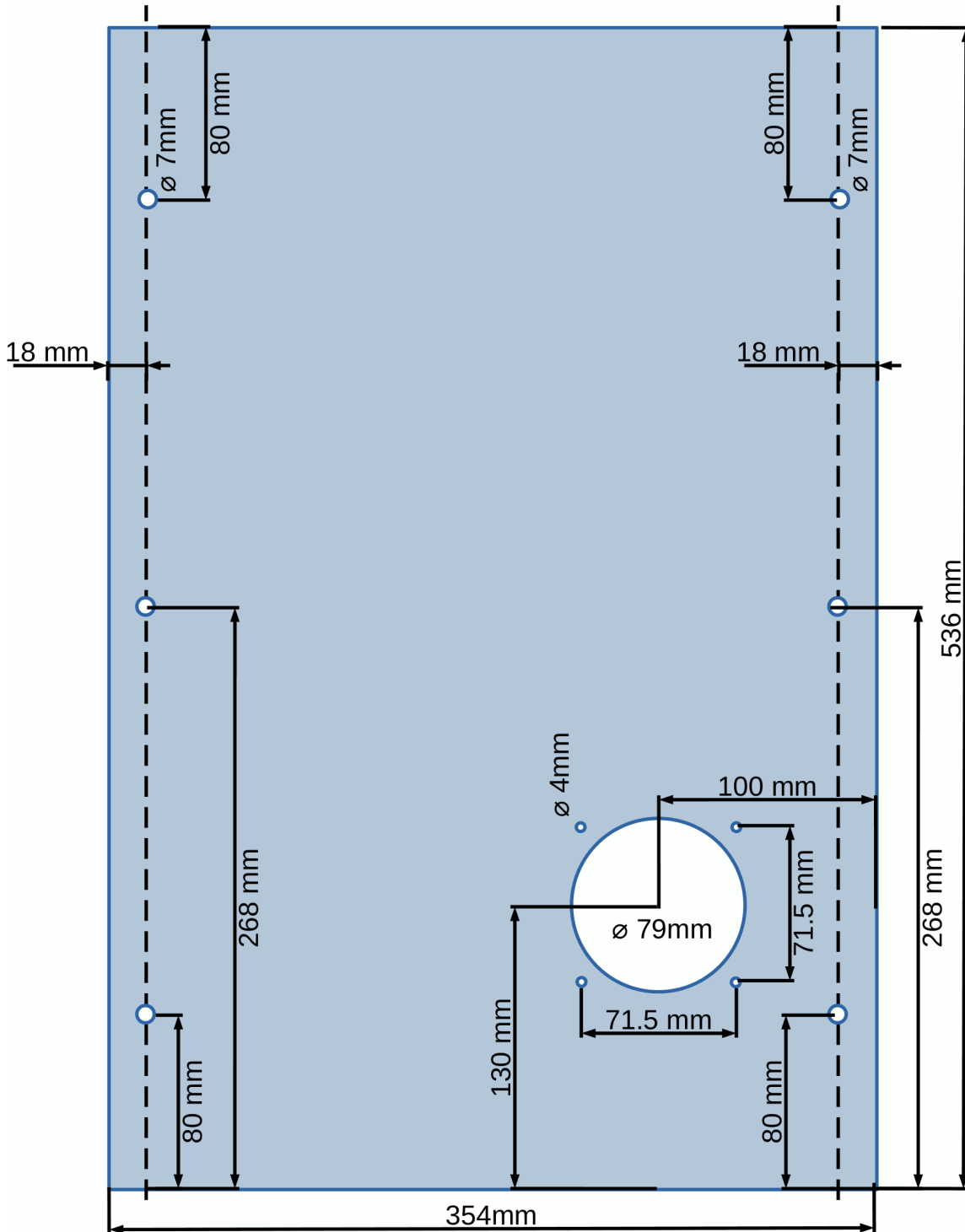



# PREPERATION OF THE PANELLING

## RIGHT SIDE PANEL

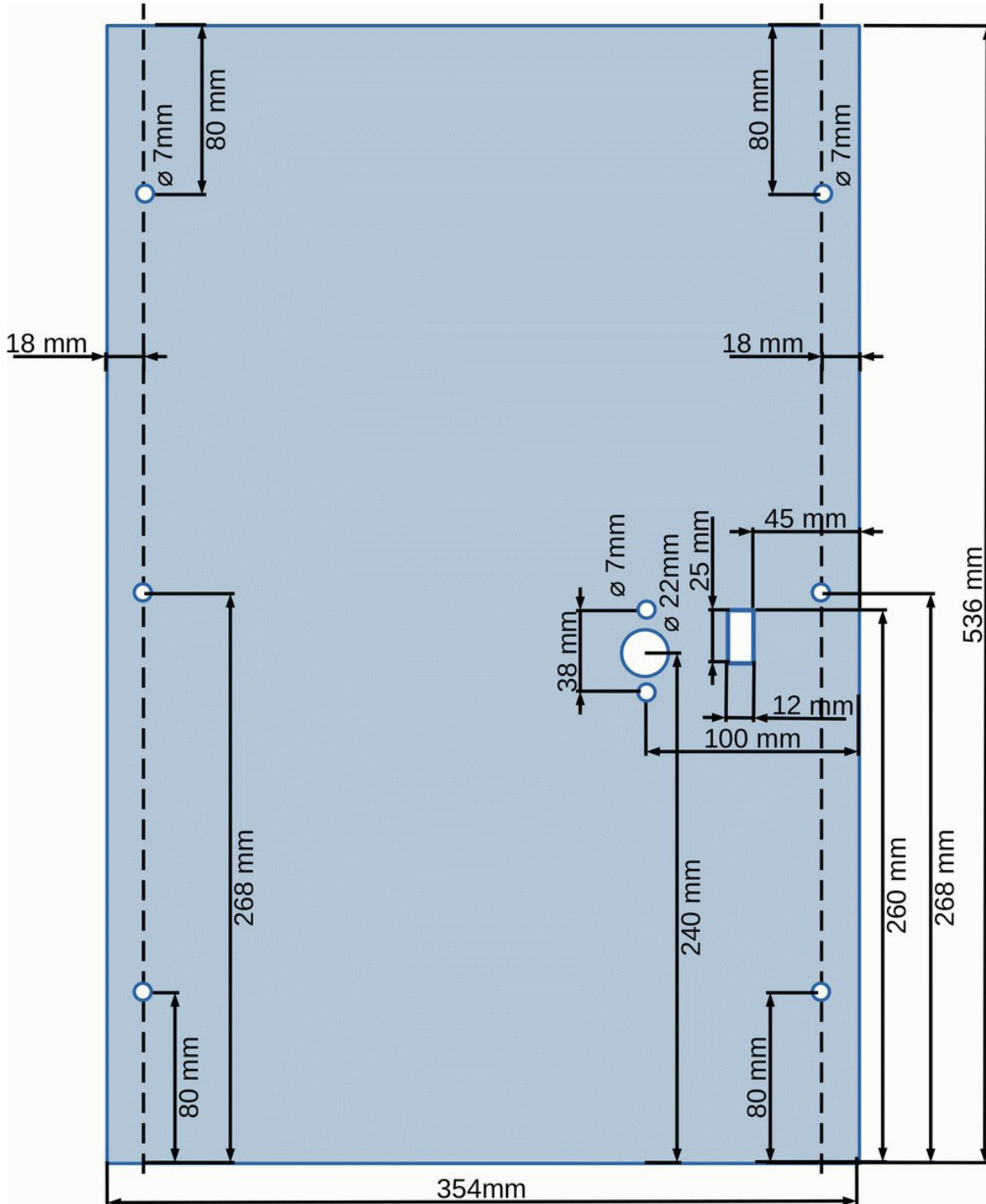

# PREPERATION OF THE PANELLING

## BACK PANEL

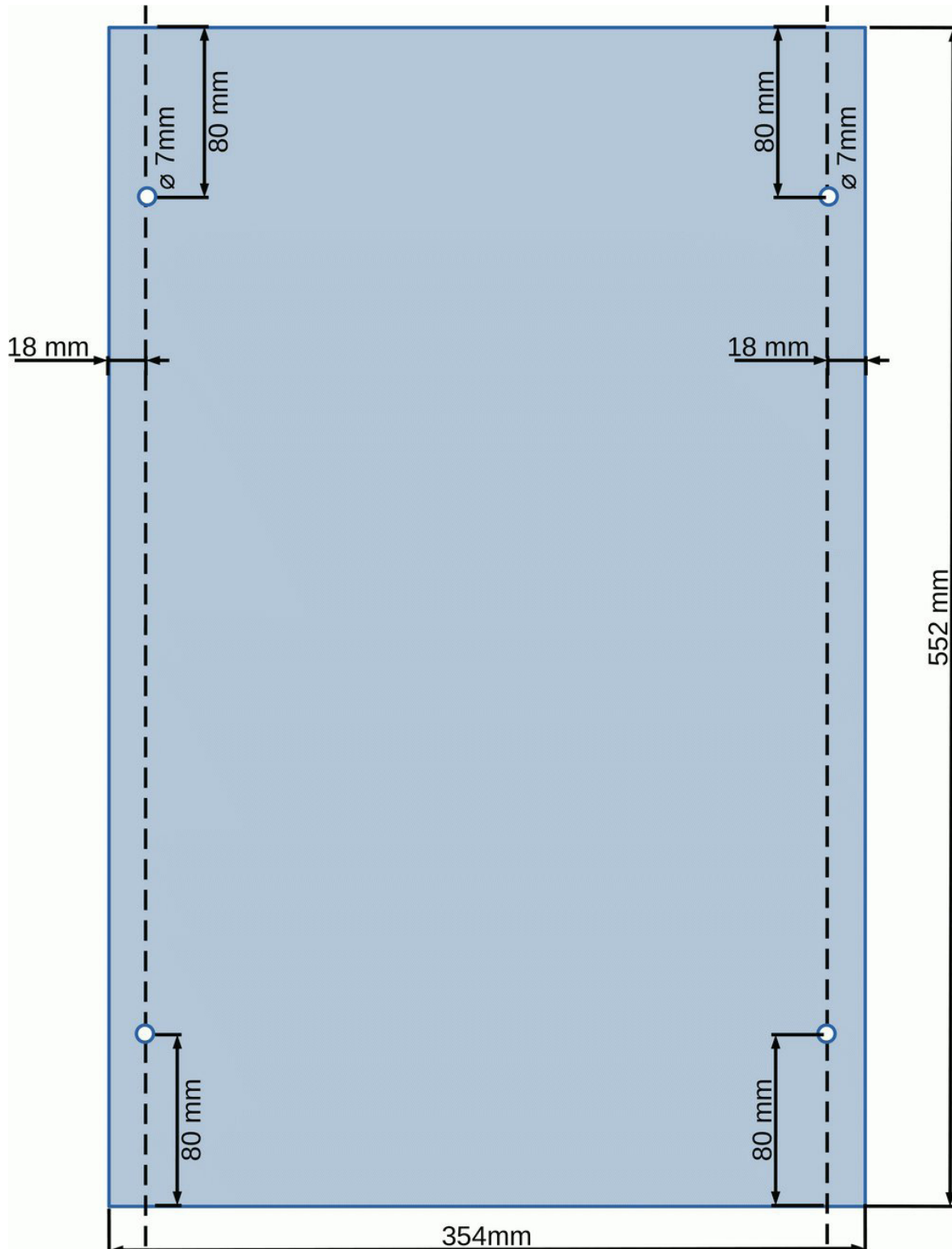

# PREPERATION OF THE PANELLING

## FRONT PANEL

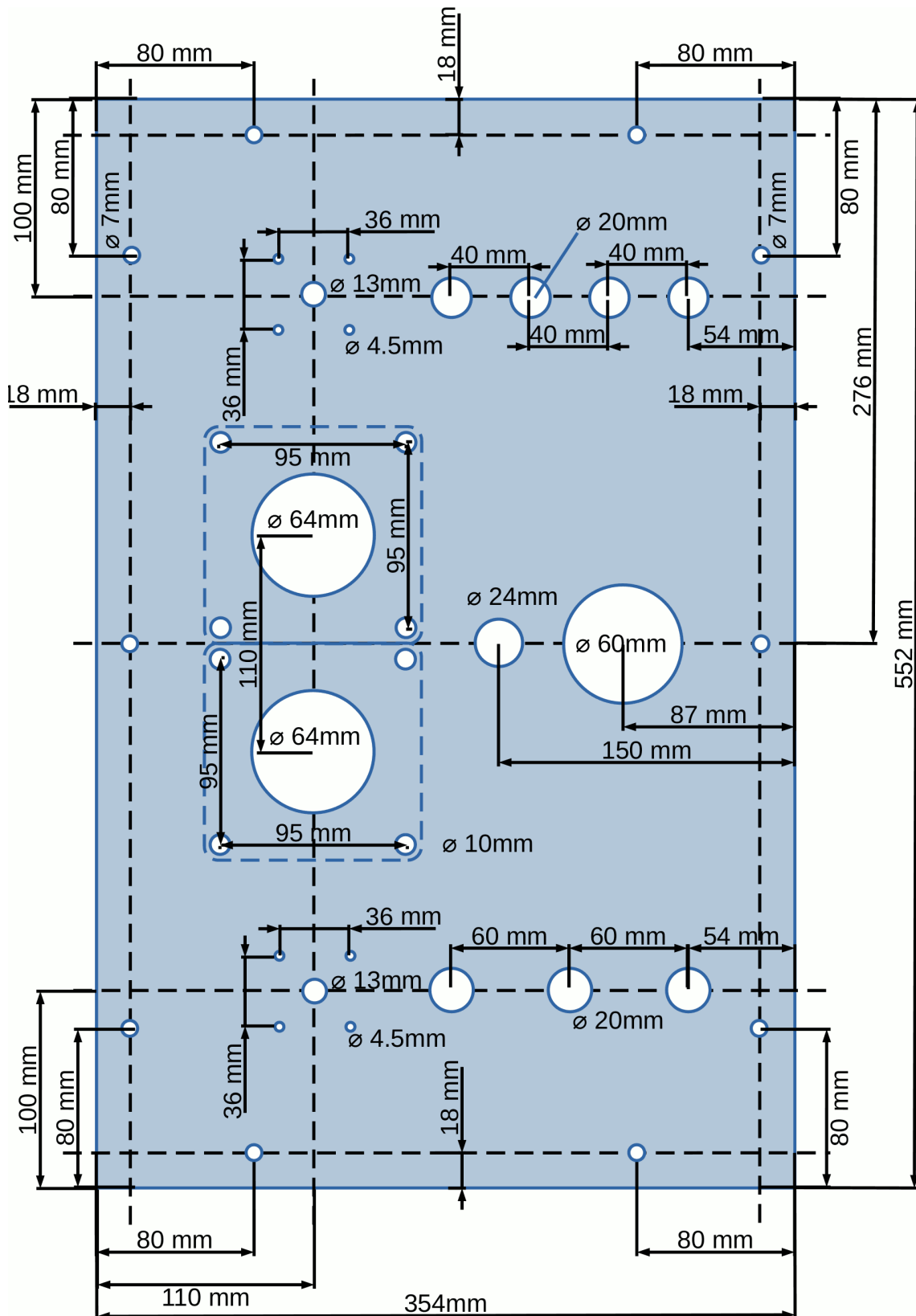

# CENTRE FRAME FOR SOLAR PANELS

## Ref. Description

- A1 1x Strut 40x40mm, 476mm length (cut to length of 761-3319)
- A2 1x Strut 40x40mm, 556mm length (cut to length of 761-3319)
- A3 2x Strut 40x40mm, 410mm length (cut to length of 761-3319)
- B 2x 767-5695 Connecting angle incl. 2x M8 t-slot nuts and M18x16 pan head screws
- C 2x 767-5711 Cube connector
- D 4x 767-5822 Self tapping screws, M8x20
- E 2x 767-5737 Pivot Joint
- F 2x 767-5660 M8 t-slot nut
- G 2x 483-9717 M8x16 pan head screw

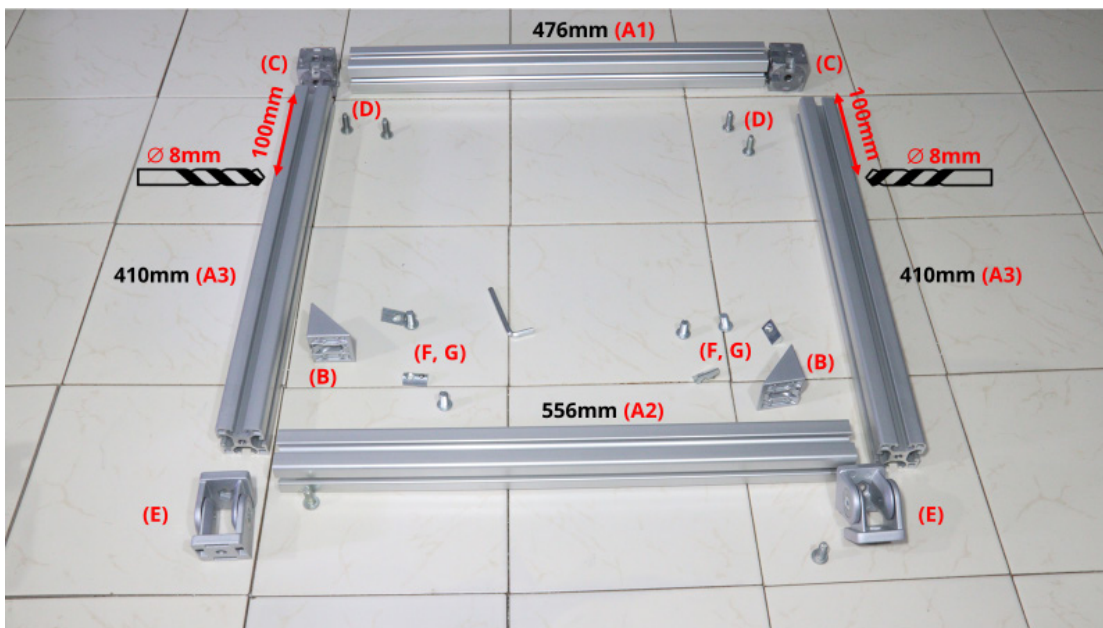

Do not forget the 8mm holes for the cable glands (100mm from the top edge)!



# LEFT FRAME FOR SOLAR PANELS

## Ref. Description

- A1 2x Strut 40x40mm, 455mm Length (Cut to length of 761-3319)
- A2 2x Strut 40x40mm, 238mm Length (Cut to length of 761-3319)
- B 4x 767-5711 Cube connector
- C 8x 767-5822 Self tapping screws, M8x20
- D 2x 767-5737 Pivot Joint
- E 2x 767-5660 M8 t-slot nut
- F 2x 483-9717 M8x16 pan head screw

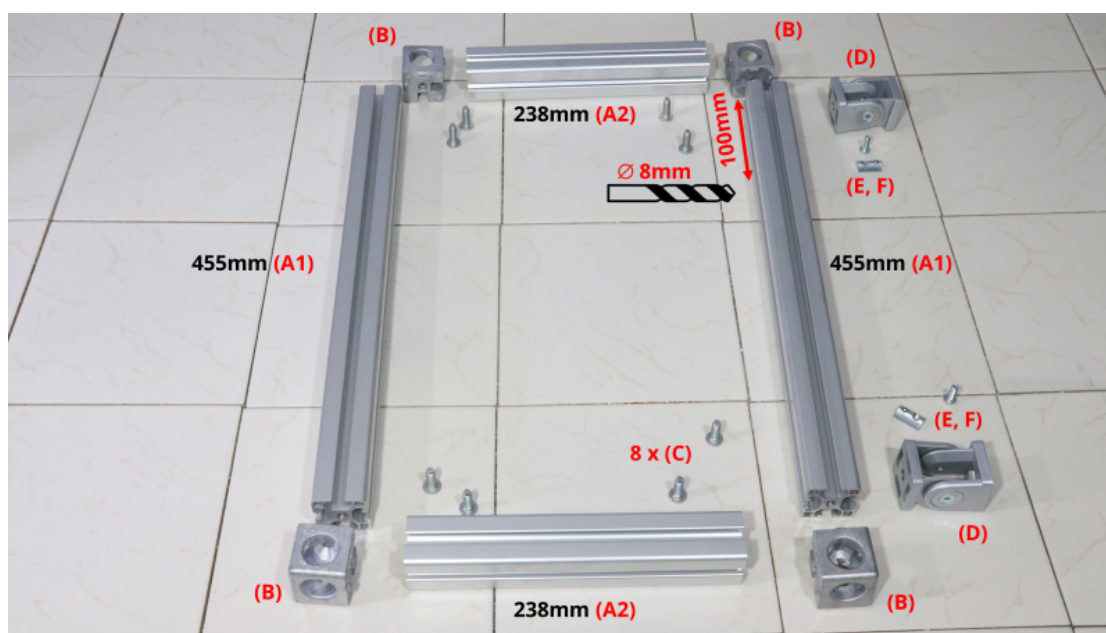

Do not forget the 8mm holes for the cable glands (100mm from the top edge)!





# RIGHT FRAME FOR SOLAR PANELS

## Ref. Description

- A1 2x Strut 40x40mm, 455mm Length (Cut to length of 761-3319)
- A2 2x Strut 40x40mm, 238mm Length (Cut to length of 761-3319)
- B 4x 767-5711 Cube connector
- C 8x 767-5822 Self tapping screws, M8x20
- D 2x 767-5737 Pivot Joint
- E 2x 767-5660 M8 t-slot nut
- F 2x 483-9717 M8x16 pan head screw

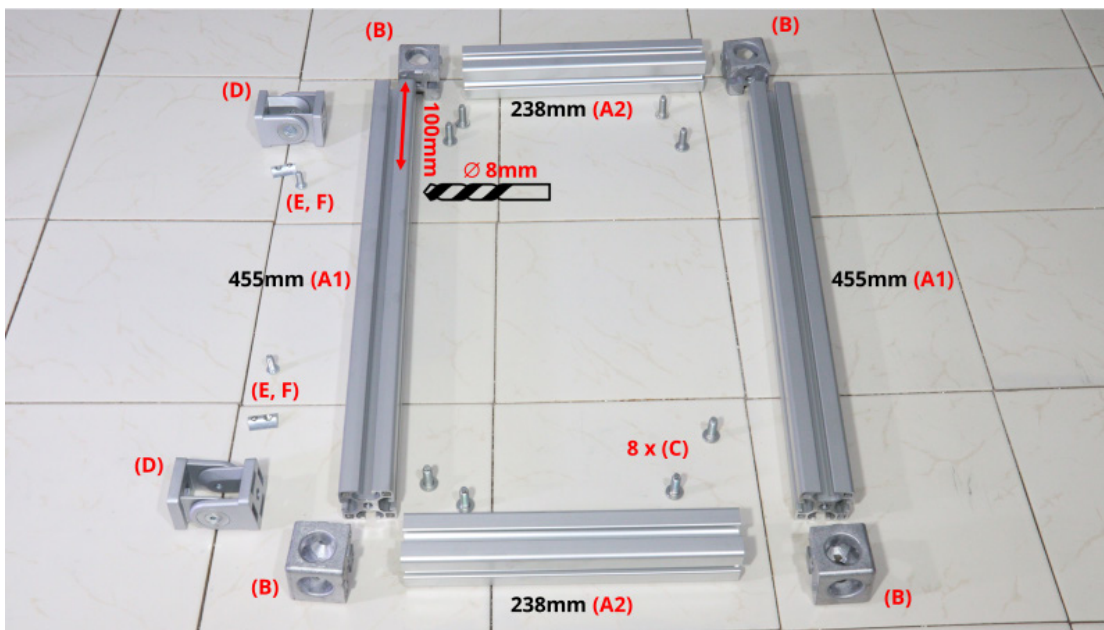

Do not forget the 8mm holes for the cable glands (100mm from the top edge)!



# SOLAR PANELS - CENTRE FRAME

## Ref. Description

- A 2x 904-6125 Solarpanel 20W 12V
- B 8x 767-5654 M6 t-slot nut
- C 6x 917-2832 M6x12 hexagon screws
- D 6x 666-7766 M6 washers, zinc plated
- E 2x 483-9672 M6x16 pan head screw
- F 1x 456-490 Plastic handle

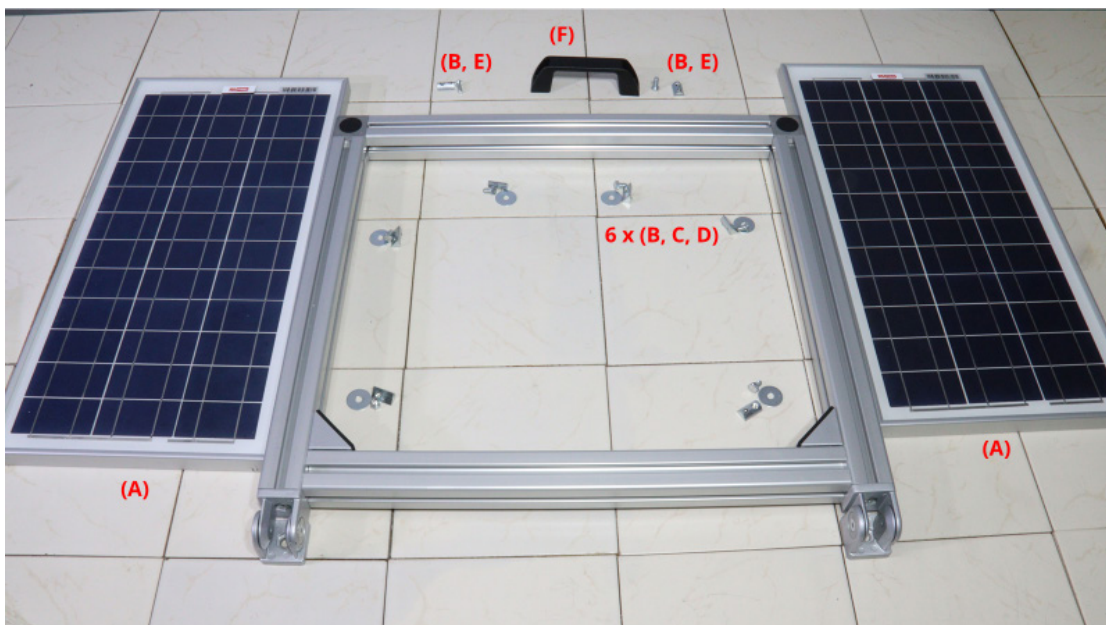

(B + C + D)  
screw on  
loosely





## SOLAR PANELS - CENTRE FRAME

Turn the solar panels and frame and slide the screws into their final position. Ensure that the frame of the solar panels is clamped between the aluminium profile and the washers before tightening the screws.



# SOLAR PANEL - LEFT+RIGHT FRAME

## Ref. Description

- A 2x 904-6125 Solarpanel 20W 12V
- B 10x 767-5654 M6 t-slot nut
- C 6x 917-2832 M6x12 hexagon screws
- D 6x 666-7766 M6 washers, zinc plated
- E 4x 483-9672 M6x16 pan head screw
- F 2x 456-490 Plastic handle



Here too, the screws and washers are initially only lightly tightened.  
To be able to slide the panels between the aluminium profile and the washers, the upper two screws must first be slid into a corner.

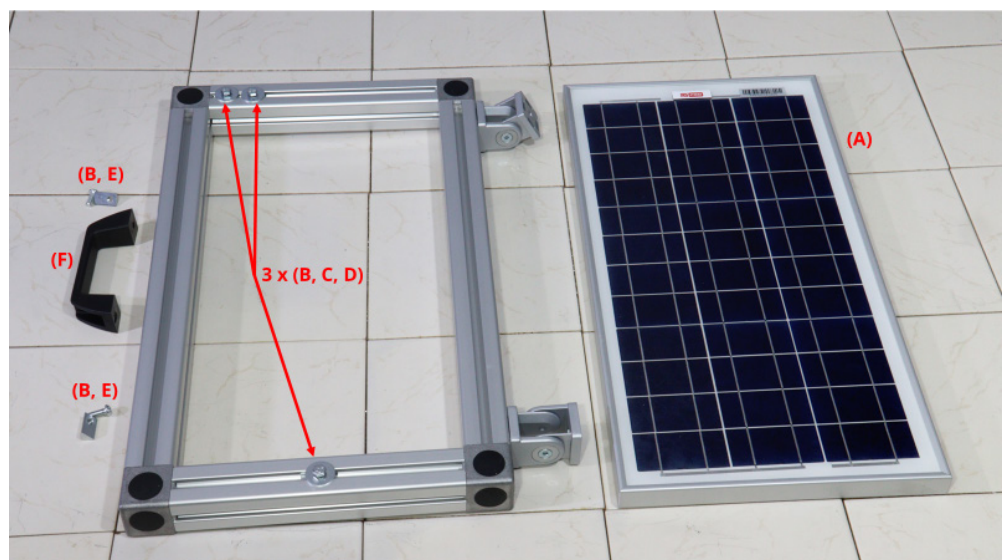



## SOLAR PANEL - LEFT+RIGHT FRAME

After turing the frames and inserting the panels, one of the upper screws must be pushed the opposite side so that the screw points are on the outer edges (as shown in the picture). The screws can then be tightened now.

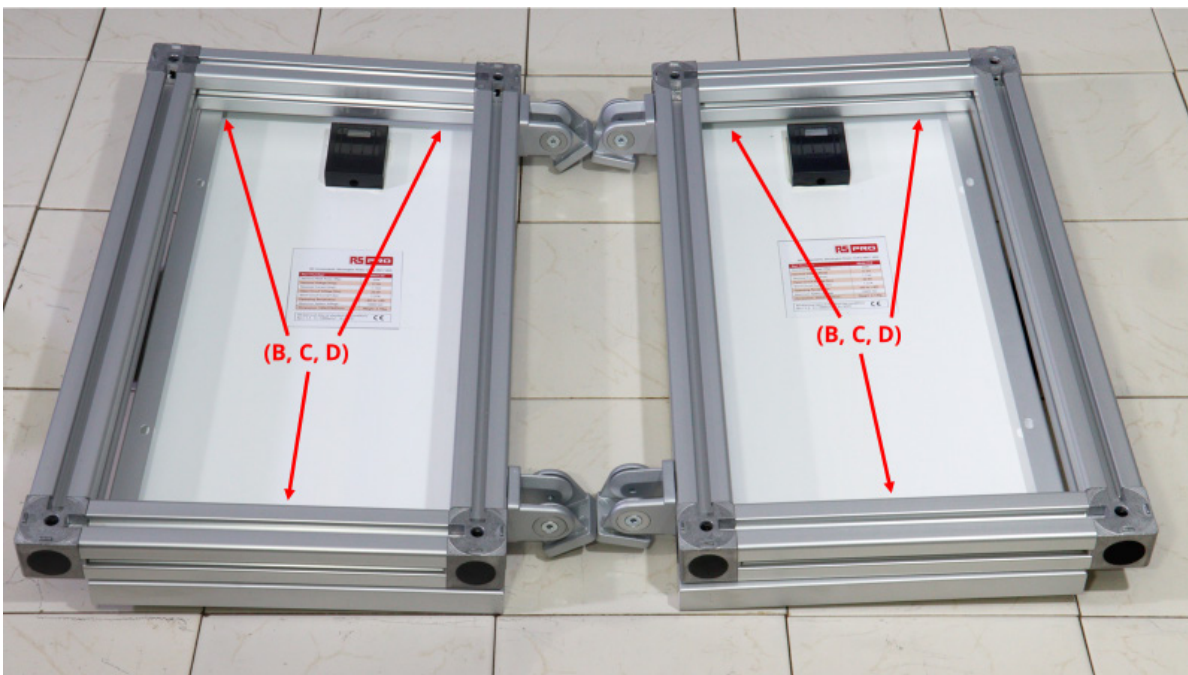

# FRAME, BOTTOM SIDE

## Ref. Description

- A1 2x Strut 40x40mm, 460mm Length (Cut to length of 761-3319)
- A2 4x Strut 40x40mm, 476mm Length (Cut to length of 761-3319)
- B 4x 767-5711 Cube connector
- C 8x 767-5822 Self tapping screws, M8x20
- D 4x 767-5695 Connecting angle incl. 2x M8 t-slot nuts and M18x16 pan head screws

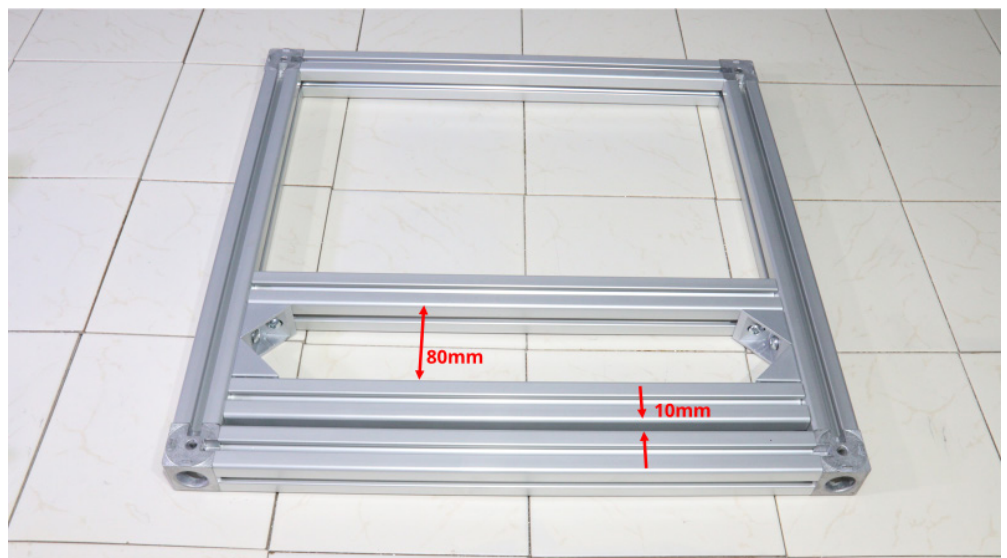
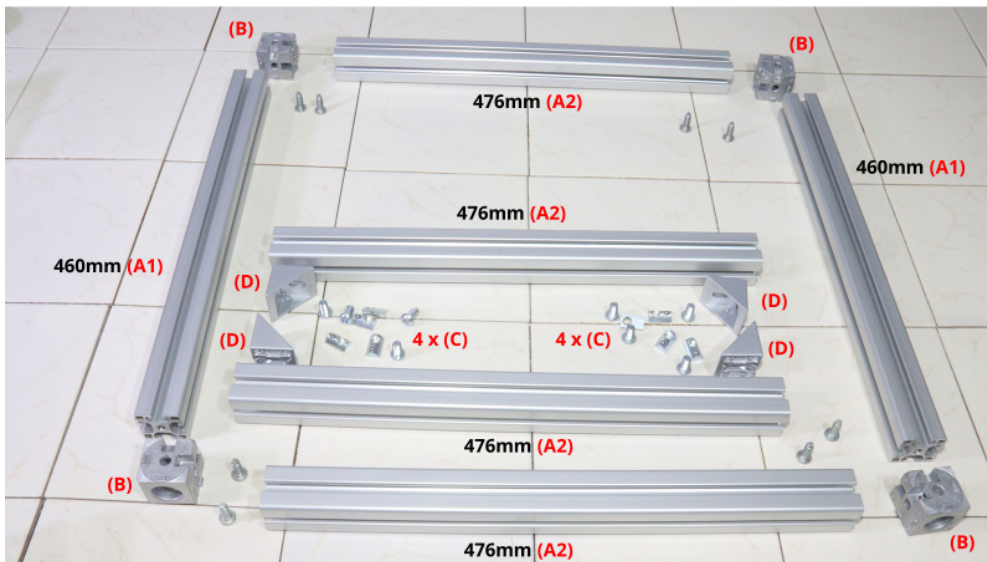



# FRAME TO HOLD THE BATTERY

## Ref. Description

- A1 1x Strut 40x40mm, 396mm Length (Cut to length of 761-3319)
- A2 2x Strut 40x40mm, 180mm Length (Cut to length of 761-3319)
- B 2x 767-5711 Cube connector
- C 4x 767-5822 Self tapping screws, M8x20
- D 2x 767-5660 M8 t-slot nut
- E 2x 483-9717 M8x16 pan head screw

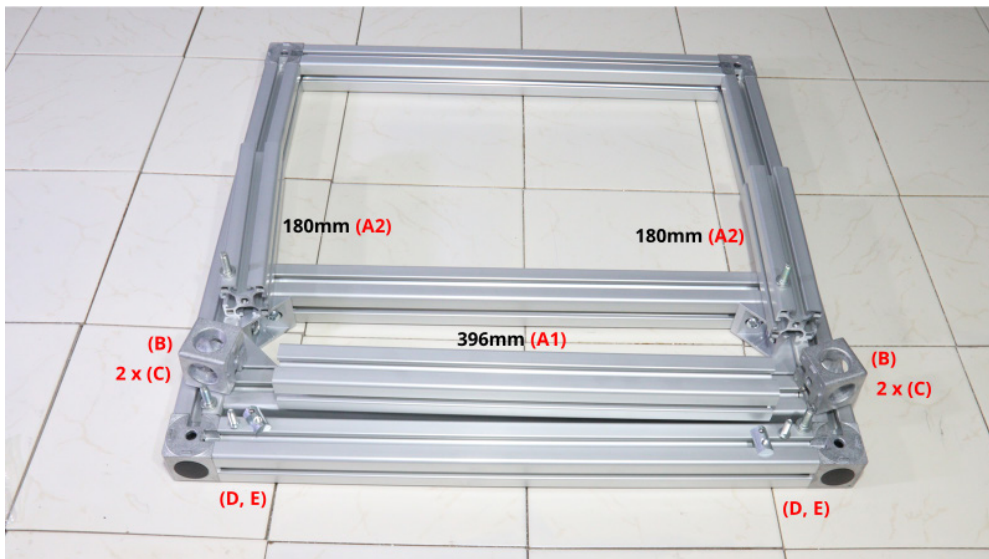

# RIGHT CUBE FRAME

## Ref. Description

- A1 1x Strut 40x40mm, 318mm Length (Cut to length of 761-3319)
- A2 2x Strut 40x40mm, 278mm Length (Cut to length of 761-3319)
- B 1x 767-5695 Connecting angle incl. 2x M8 t-slot nuts and M18x16 pan head screws
- C 2x 767-5822 Self tapping screws, M8x20

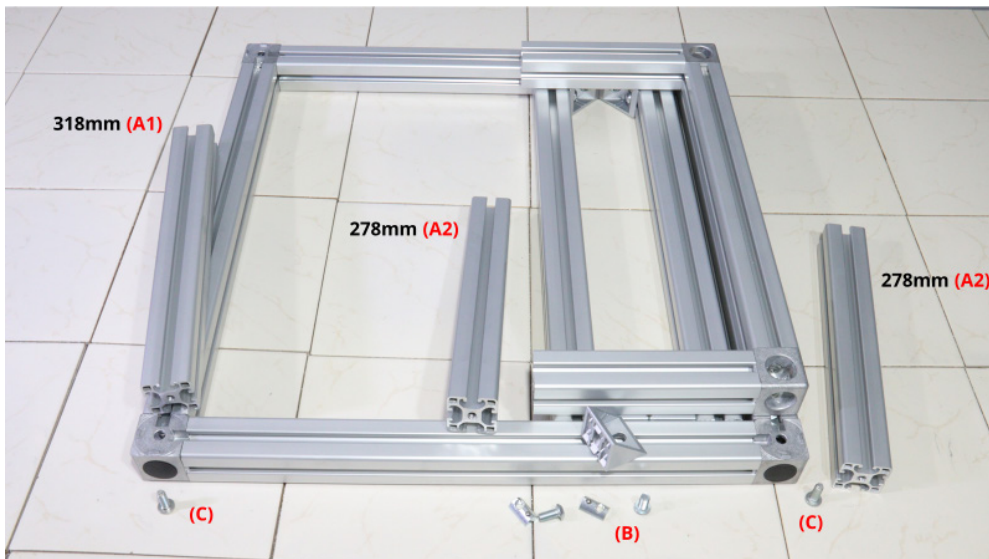

# LEFT CUBE FRAME

## Ref. Description

- A1 1x Strut 40x40mm, 318mm Length (Cut to length of 761-3319)
- A2 2x Strut 40x40mm, 278mm Length (Cut to length of 761-3319)
- A3 1x Strut 40x40mm, 476mm Length (Cut to length of 761-3319)
- B 3x 767-5695 Connecting angle incl. 2x M8 t-slot nuts and M18x16 pan head screws
- C 2x 767-5822 Self tapping screws, M8x20

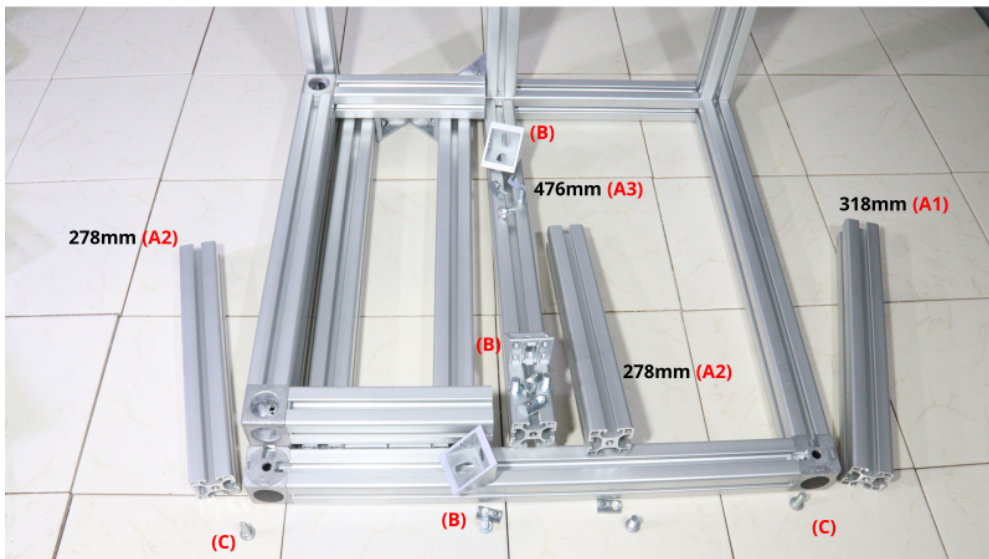



# UPPER CUBE FRAME

## Ref. Description

- A1 2x Strut 40x40mm, 476mm Length (Cut to length of 761-3319)
- A2 2x Strut 40x40mm, 460mm Length (Cut to length of 761-3319)
- B 6x 767-5695 Connecting angle incl. 2x M8 t-slot nuts and M18x16 pan head screws
- C 2x 767-5711 Cube connector
- D 4x 767-5822 Self tapping screws, M8x20

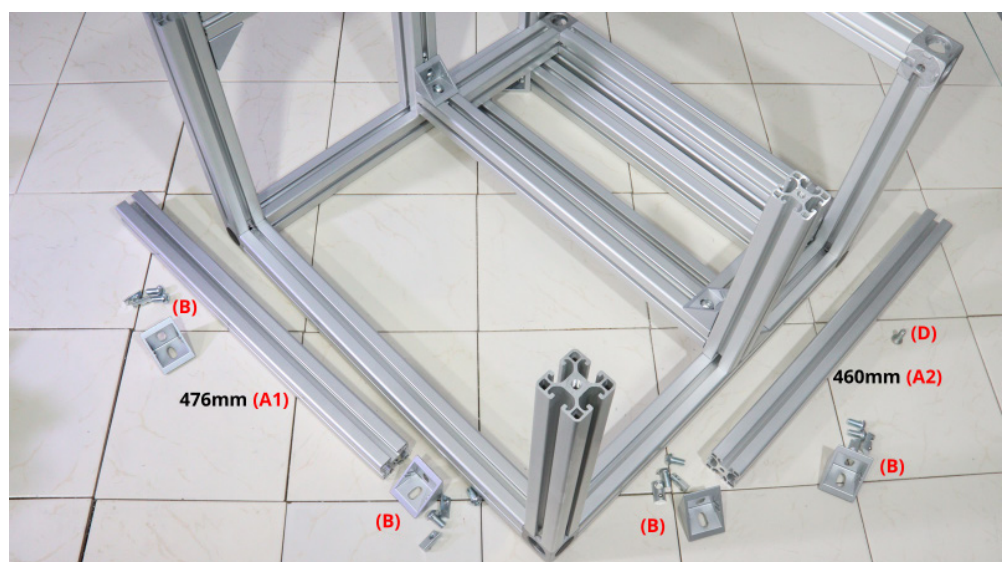
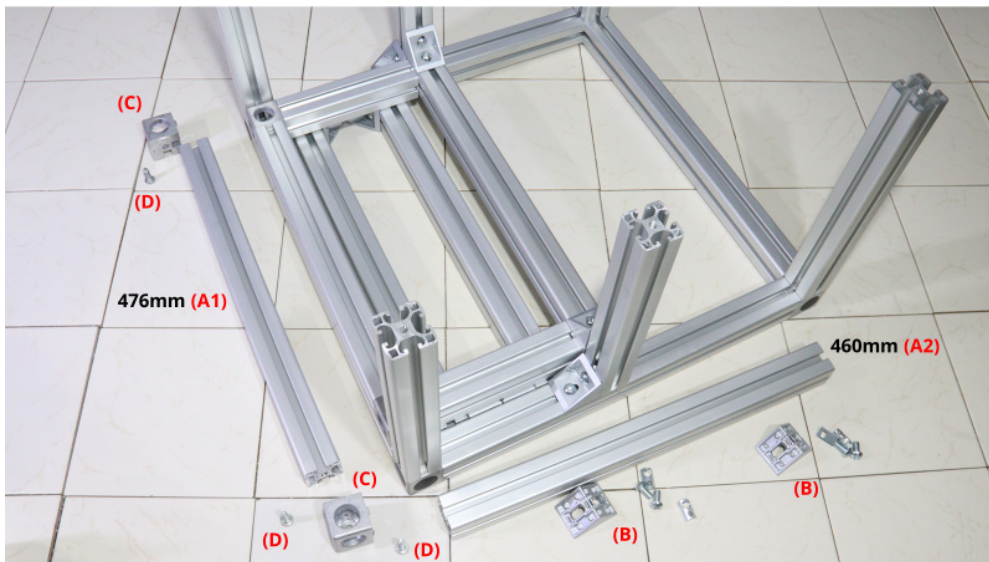

# UPPER CUBE FRAME

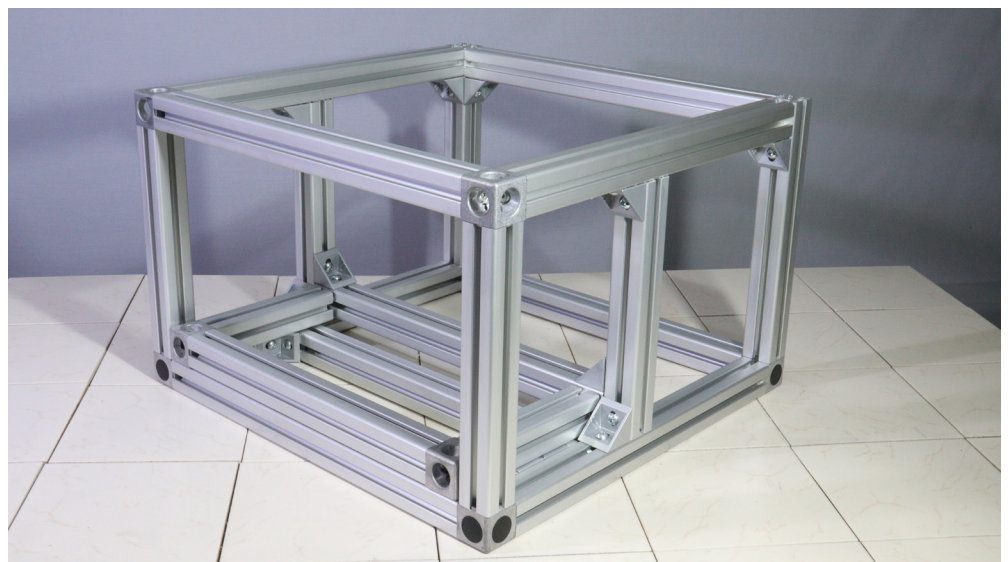



# UPPER CUBE FRAME

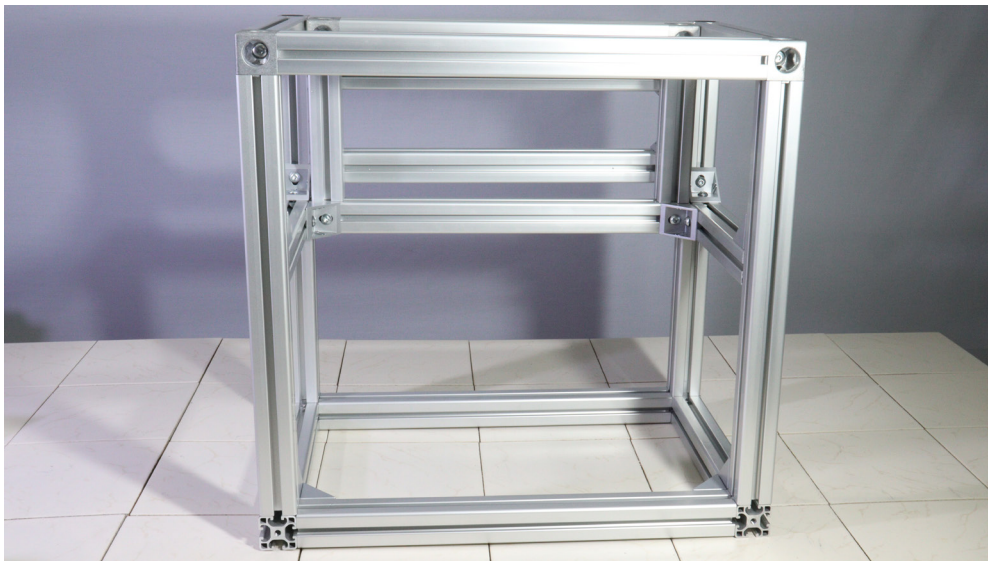
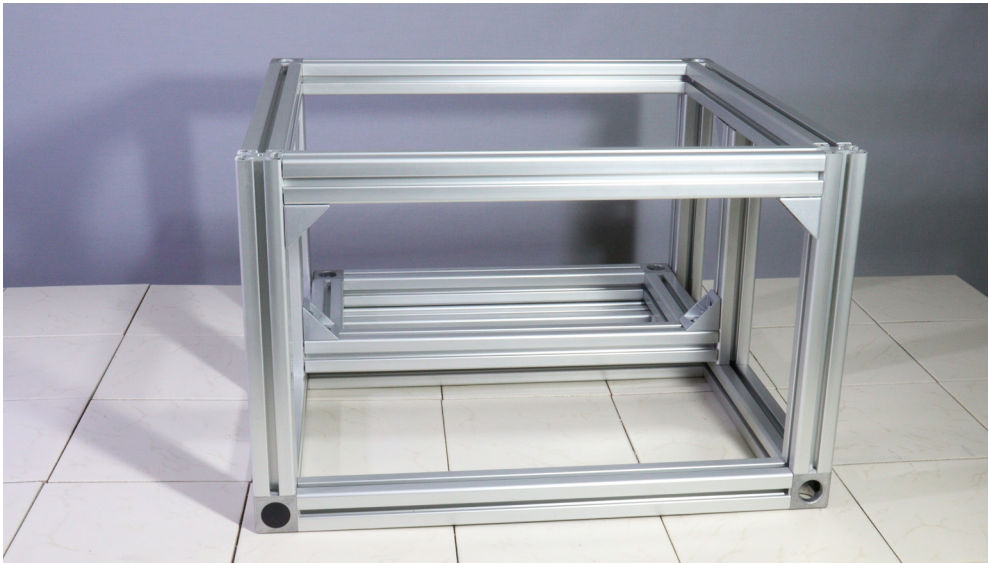

# WHEELS

## Ref. Description

- A 4x 313-2734 Wheels
- B 4x 767-5660 M8 t-slot nut
- C 12x 666-7772 Zinc plated washer M8

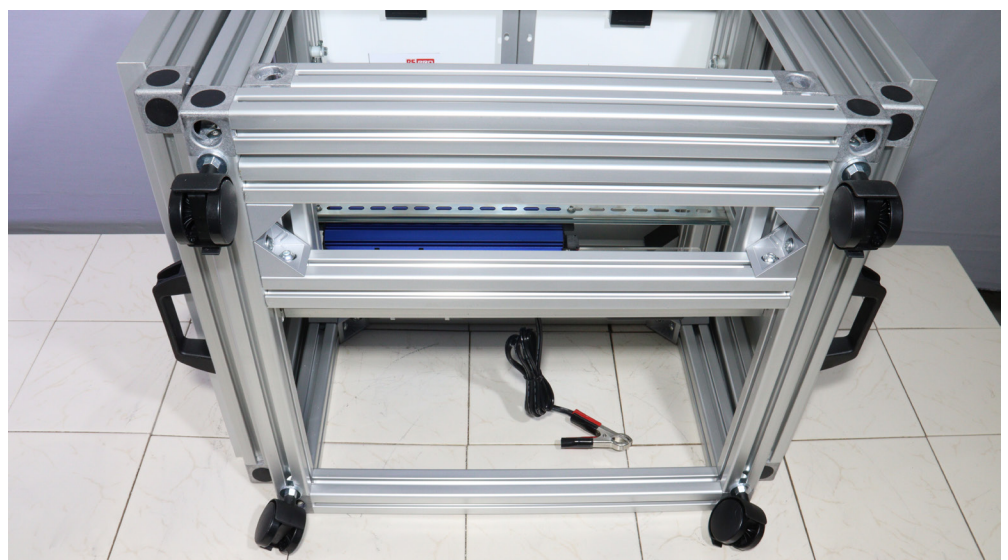
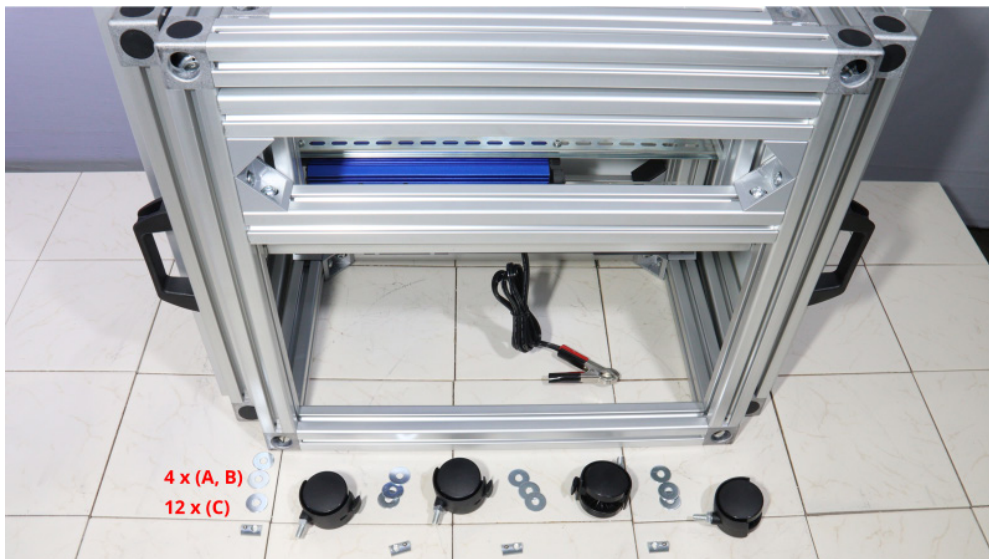



# DIN RAILS

## Ref. Description

- A 3x 467-416 DIN Rails
- B 6x 767-5654 M6 t-slot nut
- C 6x 483-9650 M6x12 Pan head screw

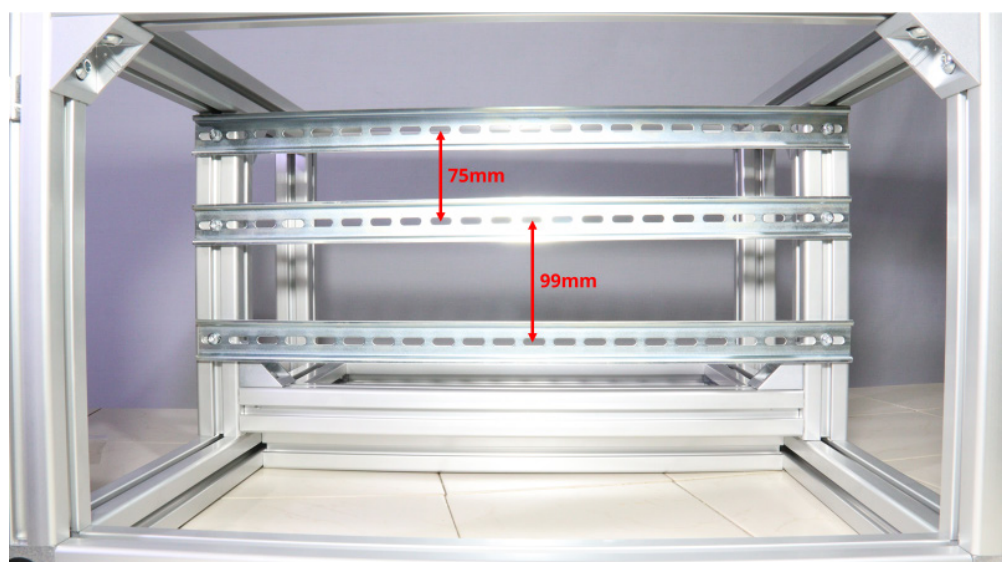
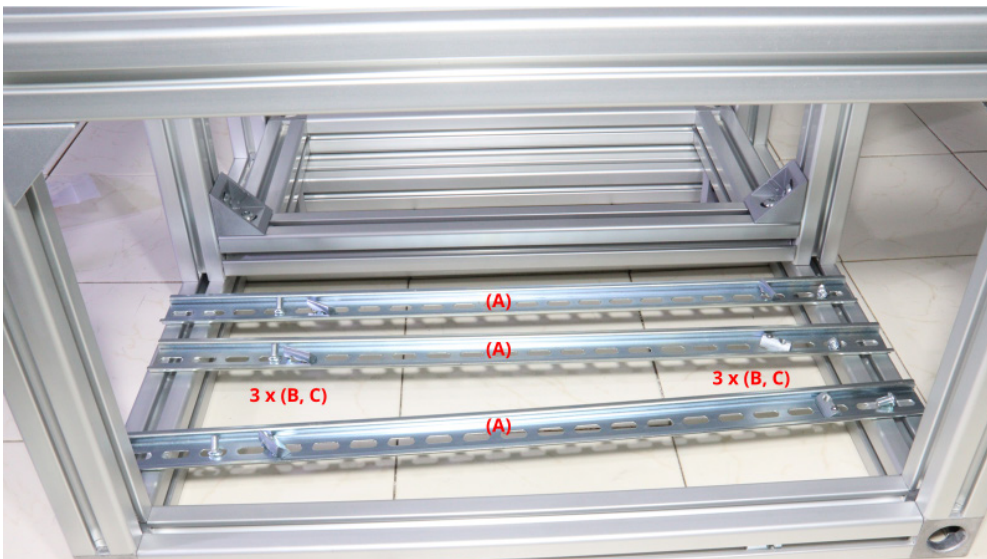

# INVERTER AND CHARGER

## Ref. Description

- A 1x 179-3330 Inverter
- B 1x 905-4532 Solar charge controller
- C 1x 549-283 Battery charger
- D 6x 483-9672 M6x16 pan head screw
- E 10x 525-919 M6 Nut
- F 12x 232-6860 Nylon Zinc plated washer
- G 4x 560-619 M3x16 pan head screw
- H 4x 560-293 M3 Nut
- I 2x 224-3135 Cable ties 265mm

To attach the inverter, one M6x16 screw, two M6 nuts and 3 nylon washers are required for each screw connection point (top right in the picture).



To attach the solar charger a remaining piece of 6mm Polycarbonate sheets (681-665) is cut to size

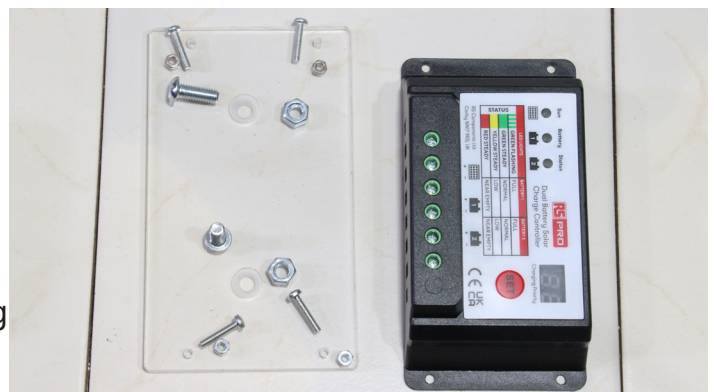

# INVERTER AND CHARGER





# CENTRE SOLAR FRAME ASSEMBLY TO THE CUBE

## Ref. Description

- A 2x 847-3116 Telescopic positioning stays
- B 28x 232-6860 Nylon Zinc plated washer
- C 4x 525-880 M6x25 hex screw
- D 4x 767-5654 M6 t-slot nut
- E 2x 767-5822 Self tapping screws, M8x20

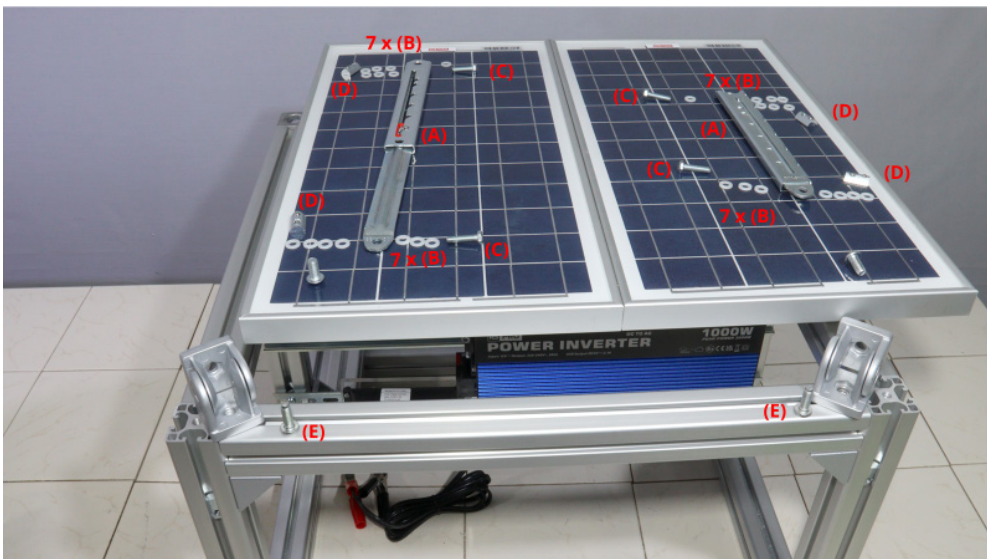

To attach the centre solar panels frame to the cube, the joints must be disassembled again. This is, because these must be screwed to the box first.



## CENTRE SOLAR FRAME ASSEMBLY TO THE CUBE

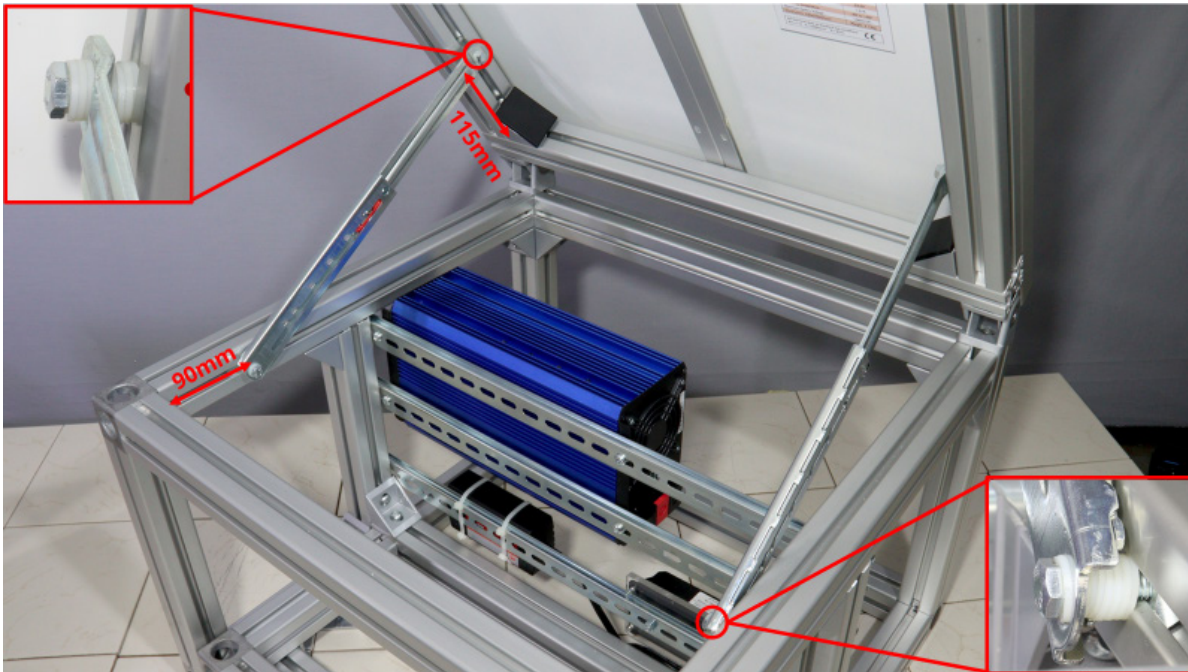

The attachment points of the telescopic positioning stays are located 90mm (on the cube) and 115mm (on the centre frame for the solar panels) from the inner edges of the aluminium profiles.

The nylon washers are used to align the telescopic rods in parallel (top left and bottom right in the picture)

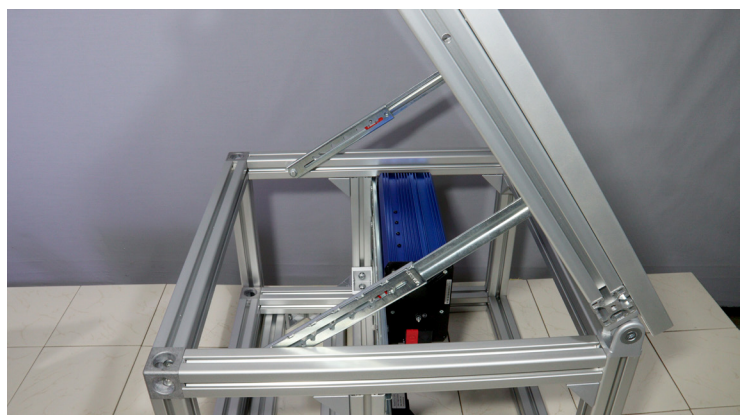



# CENTRE SOLAR FRAME ASSEMBLY TO THE CUBE



# LEFT AND RIGHT SOLAR FRAME TO THE CUBE

## Ref. Description

- A 2x 767-5660 M8 t-slot nut
- B 2x 483-9717 M8x16 pan head screw
- C 2x 767-5822 Self tapping screws, M8x20



To attach the left and right solar panels to the cube, the joints must be unscrewed again. This is because these must first be screwed to the cube.

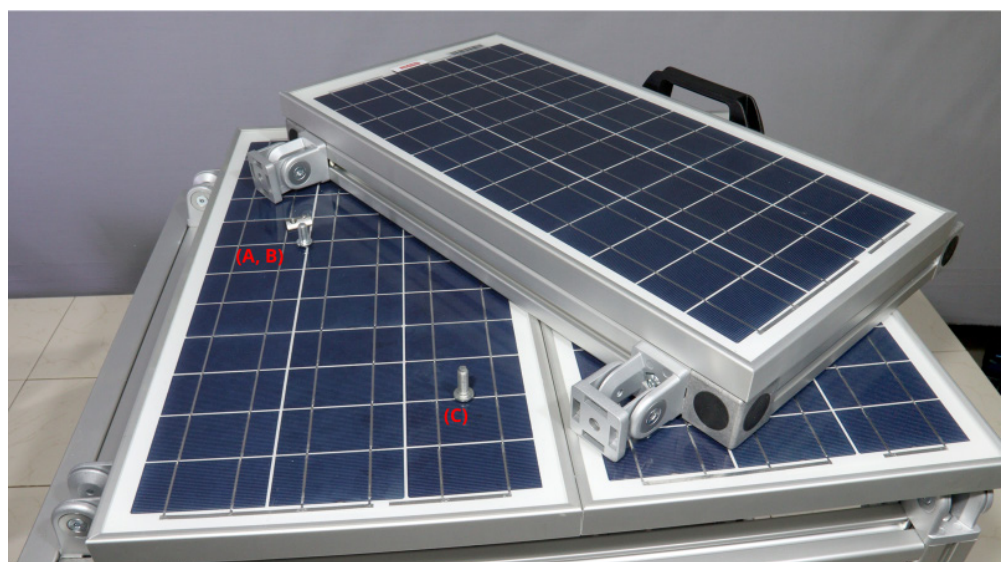



# LEFT AND RIGHT SOLAR FRAME TO THE CUBE



# LEFT AND RIGHT SOLAR FRAME TO THE CUBE

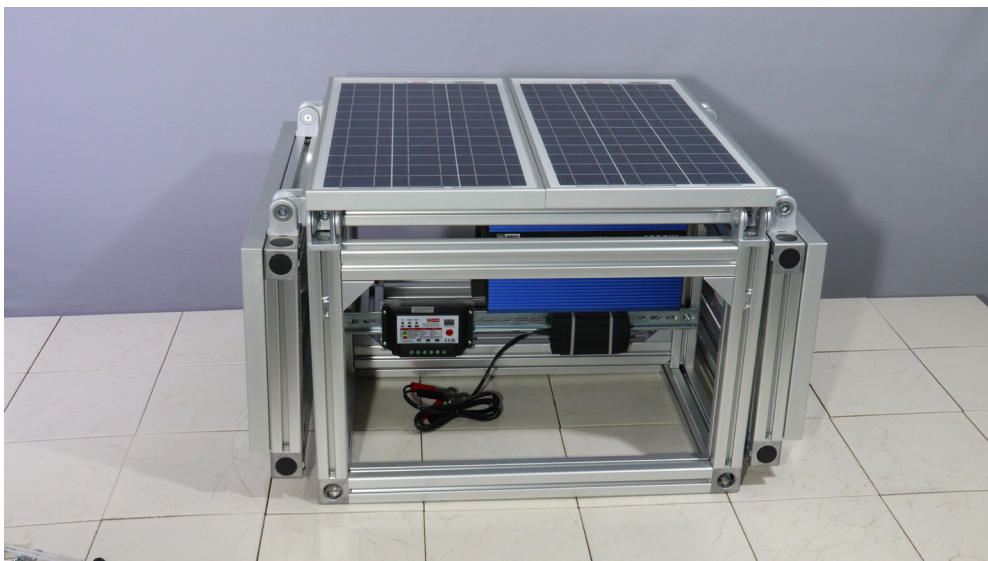



# PANEL, BOTTOM SIDE

## Ref. Description

- A 5x 767-5654 M6 t-slot nut
- B 5x 483-9672 M6x16 pan head screw
- C 5x 232-6860 Nylon Zinc plated washer
- D 3x 666-7766 Zinc plated washer M6

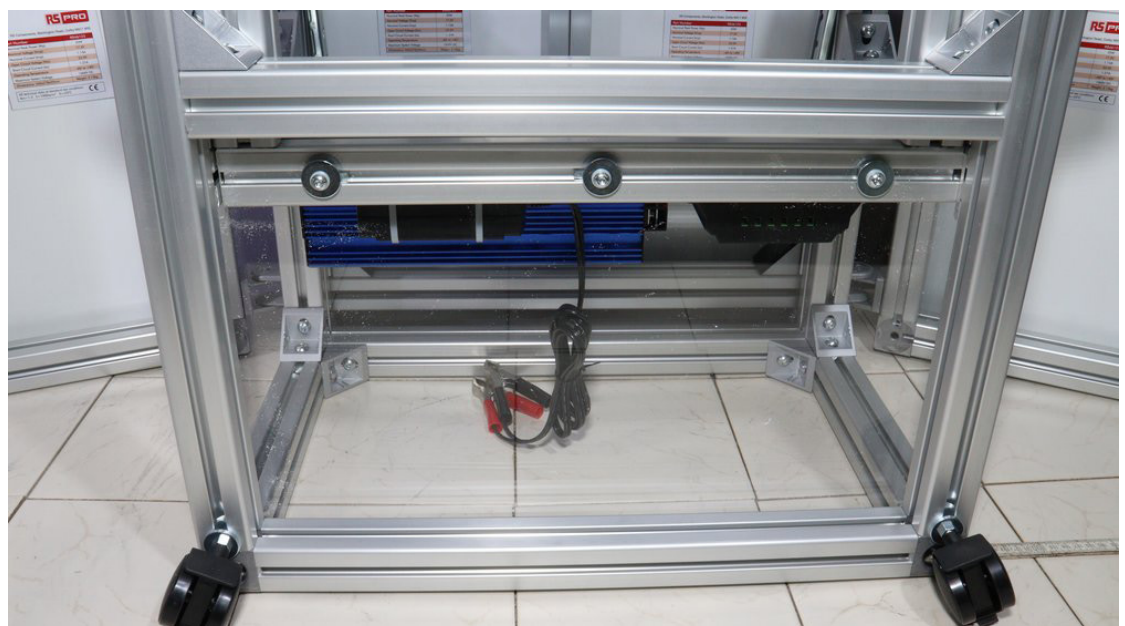
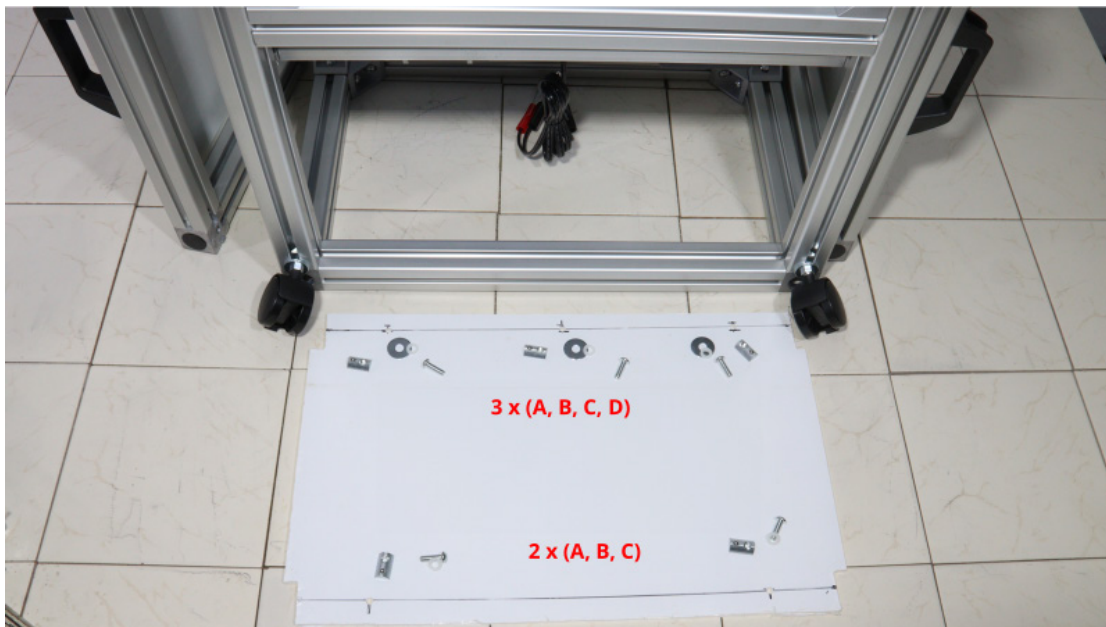



# PANEL, FRONT SIDE

## Ref. Description

- A 4x 273-003 Illuminated rocker switch, red
- B 2x 466-150 Panel Mount Isolator Switch
- C 2x 763-7909 Indicator, red
- D 1x 763-7918 Indicator, green
- E 1x 233-7809 Voltmeter
- F 1x 111-6748 USB-socket
- G 1x 214-4099 Panel socket-outlet type F
- H 1x 214-4166 Angled panel industrial socket-outlet
- I 2x 197-2006 General purpose enclosures
- J 10x 483-9672 M6x16 pan head screw
- K 10x 232-6860 Nylon Zinc plated washer
- L 10x 767-5654 T-nut M6

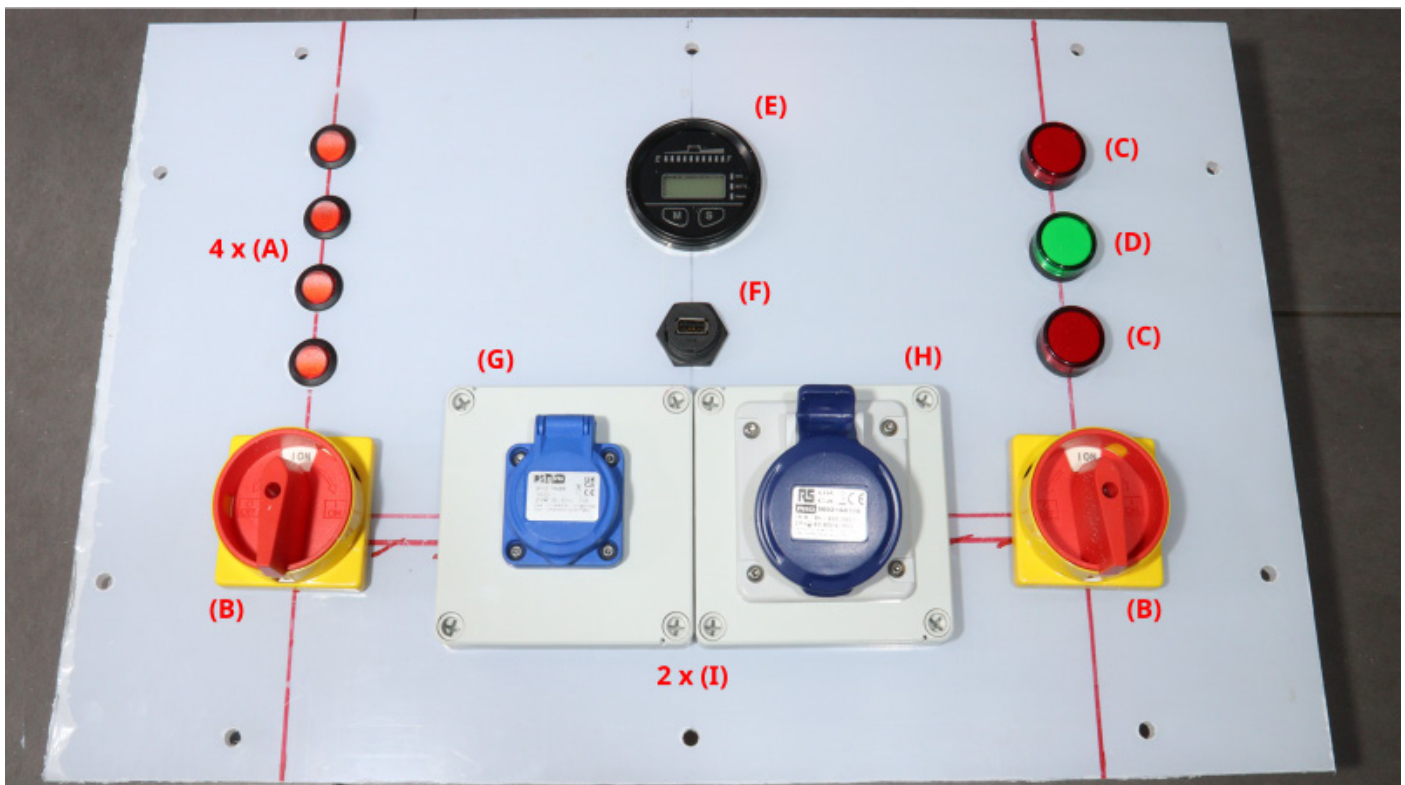

# PANEL, FRONT SIDE

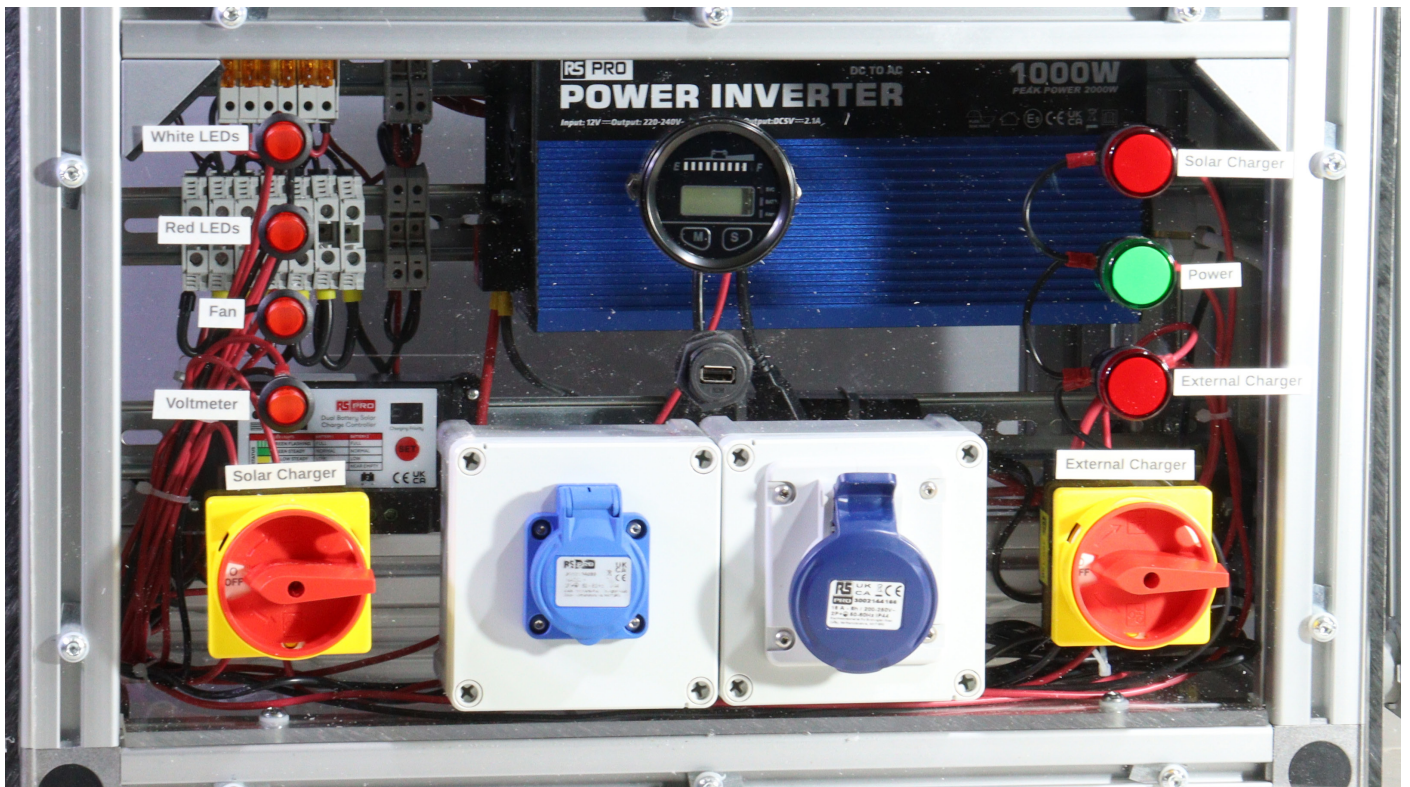

# PANEL, RIGHT

## Ref. Description

- A 6x 483-9672 M6x16 pan head screw
- B 6x 232-6860 Nylon Zinc plated washer
- C 6x 767-5654 T-nut M6
- D 1x 325-4840 Battery isolator switch
- E 2x 483-9688 M6x20 screw
- F 2x 525-919 M6 Nut
- G 1x 174-5456 Panel-mount IEC-connector C8

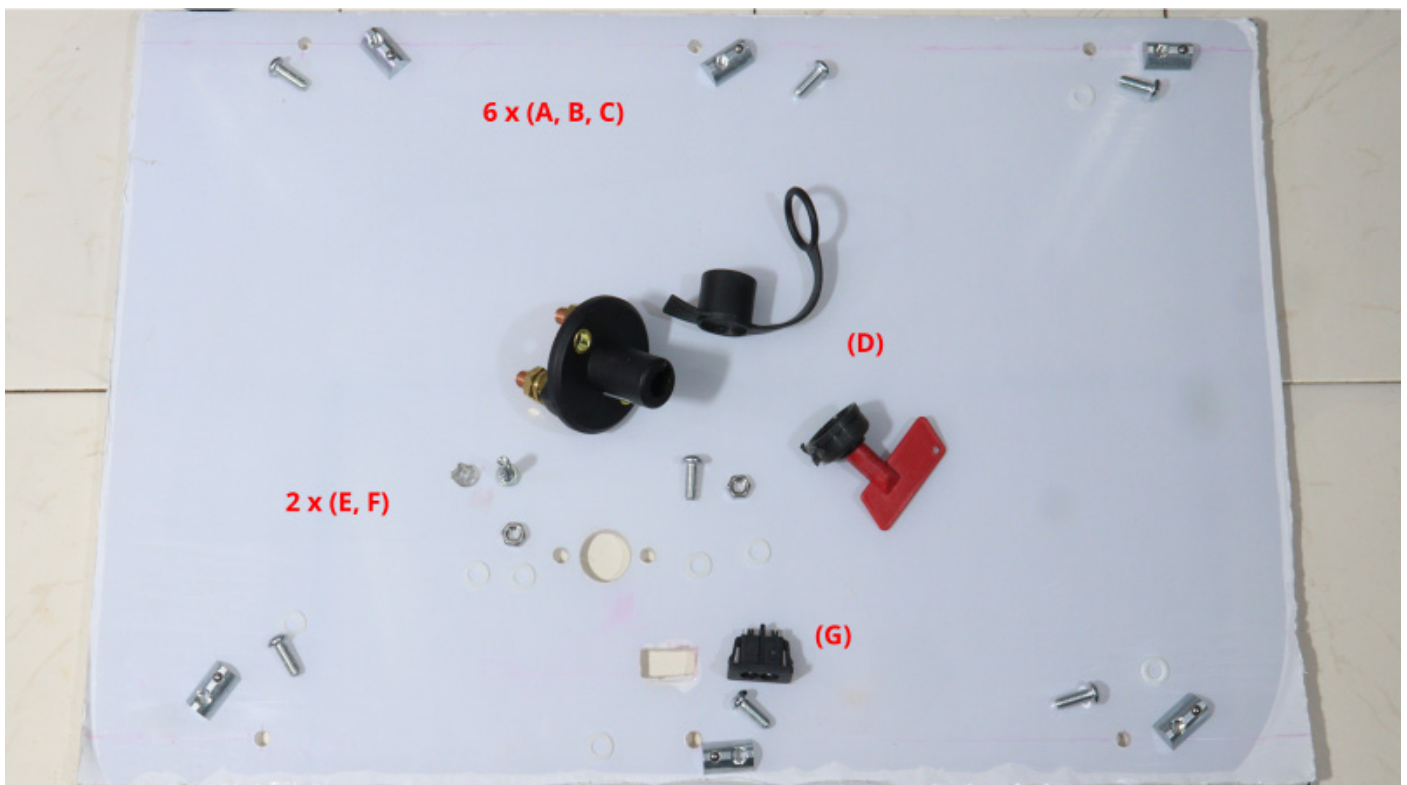



# PANEL, LEFT

## Ref. Description

- A 6x 483-9672 M6x16 pan head screw
- B 6x 232-6860 Nylon Zinc plated washer
- C 6x 767-5654 T-nut M6
- D 1x 668-8839 Fan
- E 4x 560-619 M3x16 pan head screw
- F 4x 560-293 M3 Nut

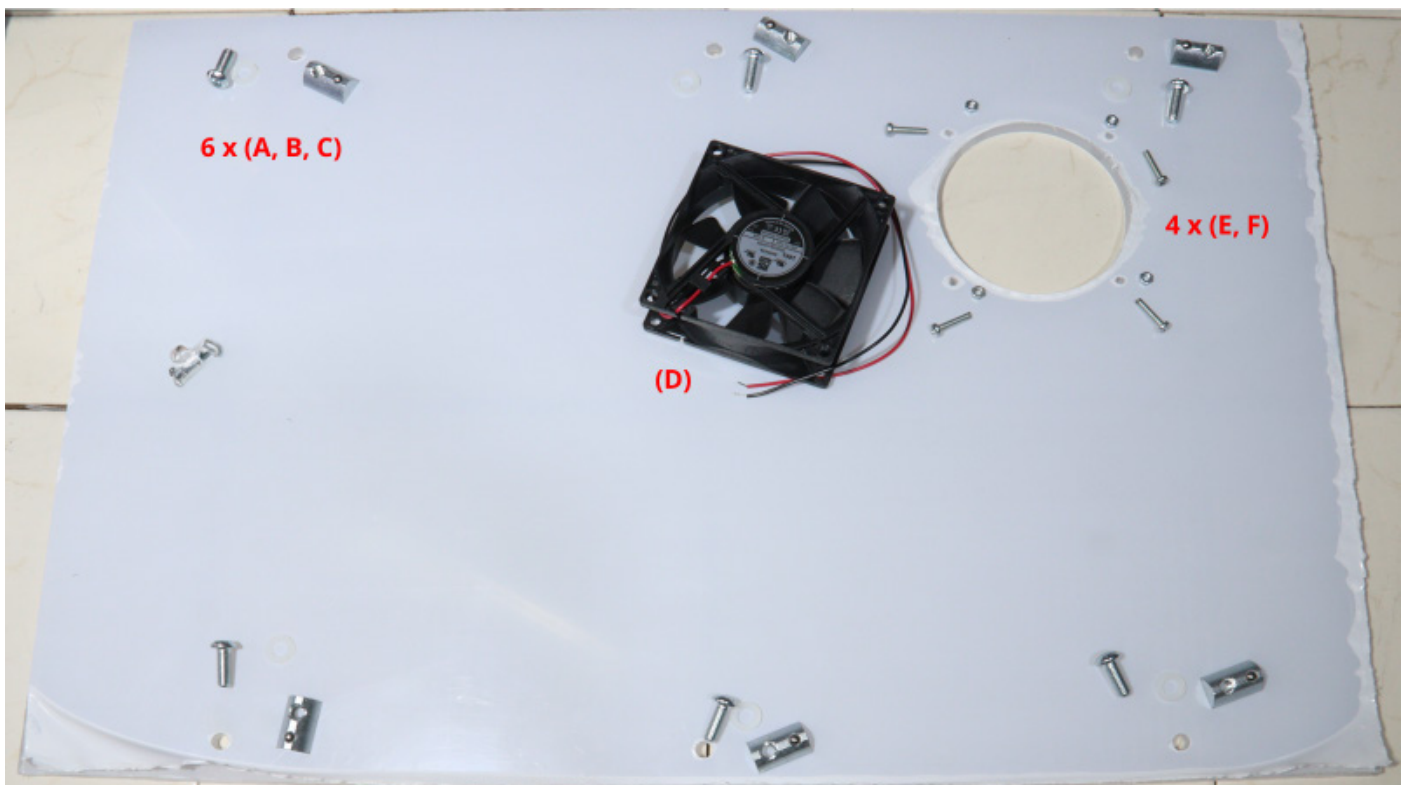

# PANEL, BACK SIDE

## Ref. Description

- A 4x 483-9672 M6x16 pan head screw
- B 4x 232-6860 Nylon Zinc plated washer
- C 4x 767-5654 T-nut M6

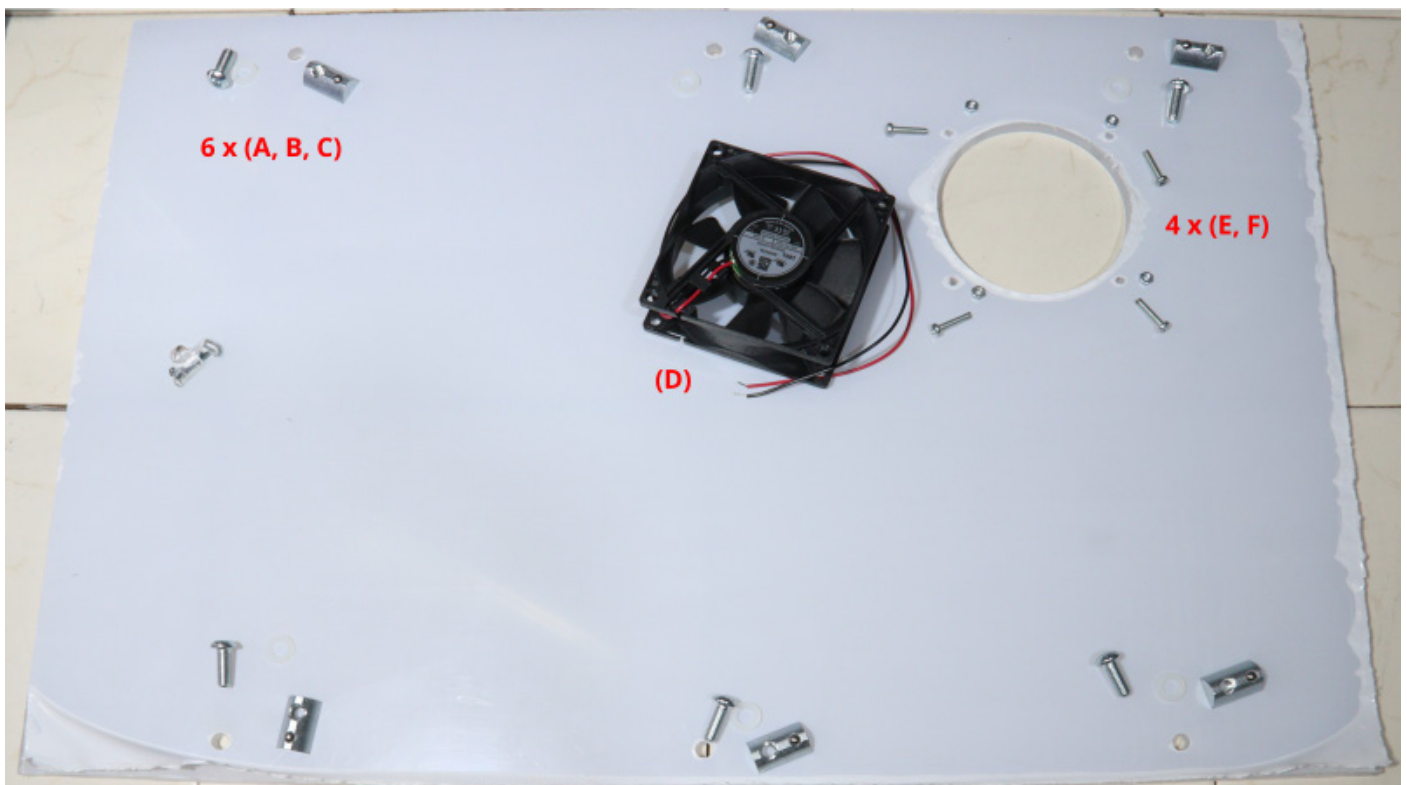

# PANEL, TOP

## Ref. Description

- A 7x 483-9672 M6x16 pan head screw
- B 7x 232-6860 Nylon Zinc plated washer
- C 7x 767-5654 T-nut M6





# BUFFER FOOT

## Ref. Description

- A 6x 126-4959 Anti-vibration buffer foot
- B 6x 525-919 M6 Nut



# WIRING: SOLARPANELS AND CHARGER

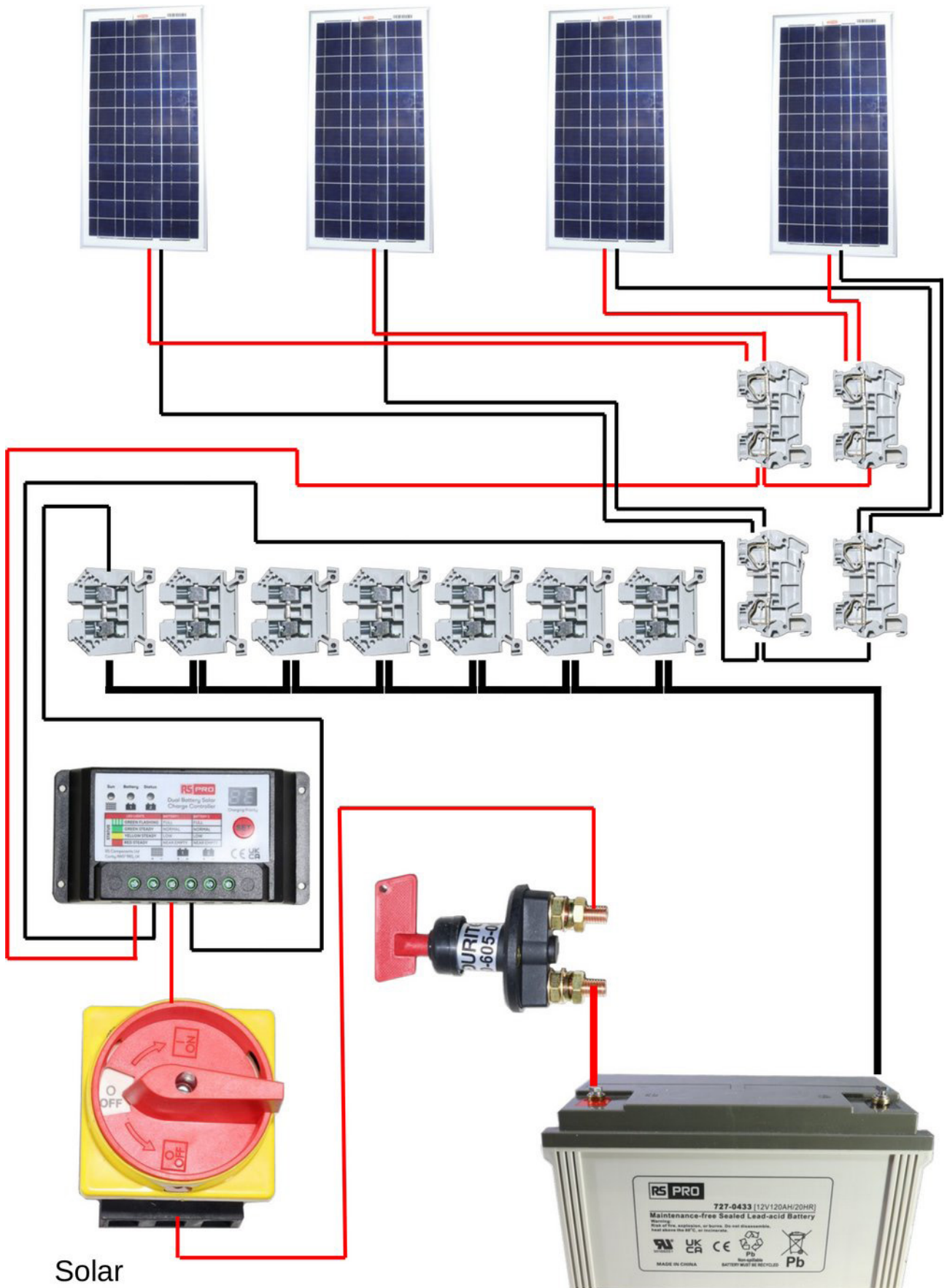

# WIRING - INDICATORS

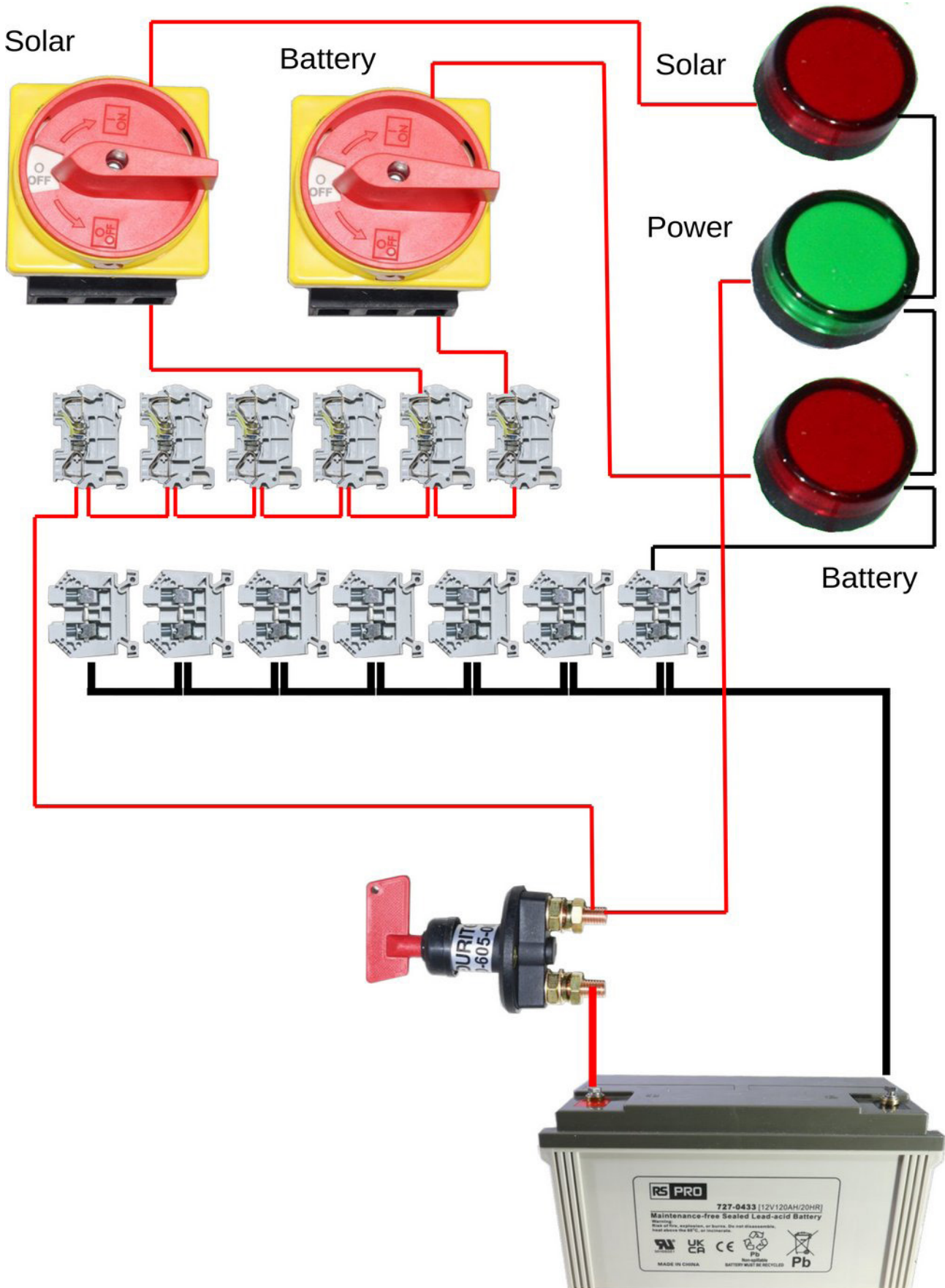



# WIRING - EXTERNAL CHARGING FUNCTION

The mains cable of the charger must be soldered to the IEC socket. To do this, the plug on one of the supplied mains cables must be cut off.

The clamps for connecting to the battery poles must be disconnected. The connection to the battery poles are shown in the drawing below.

Ensure that the polarity is correct!

The cable to the positive pole of the charger is marked, while the negative pole is not labelled.

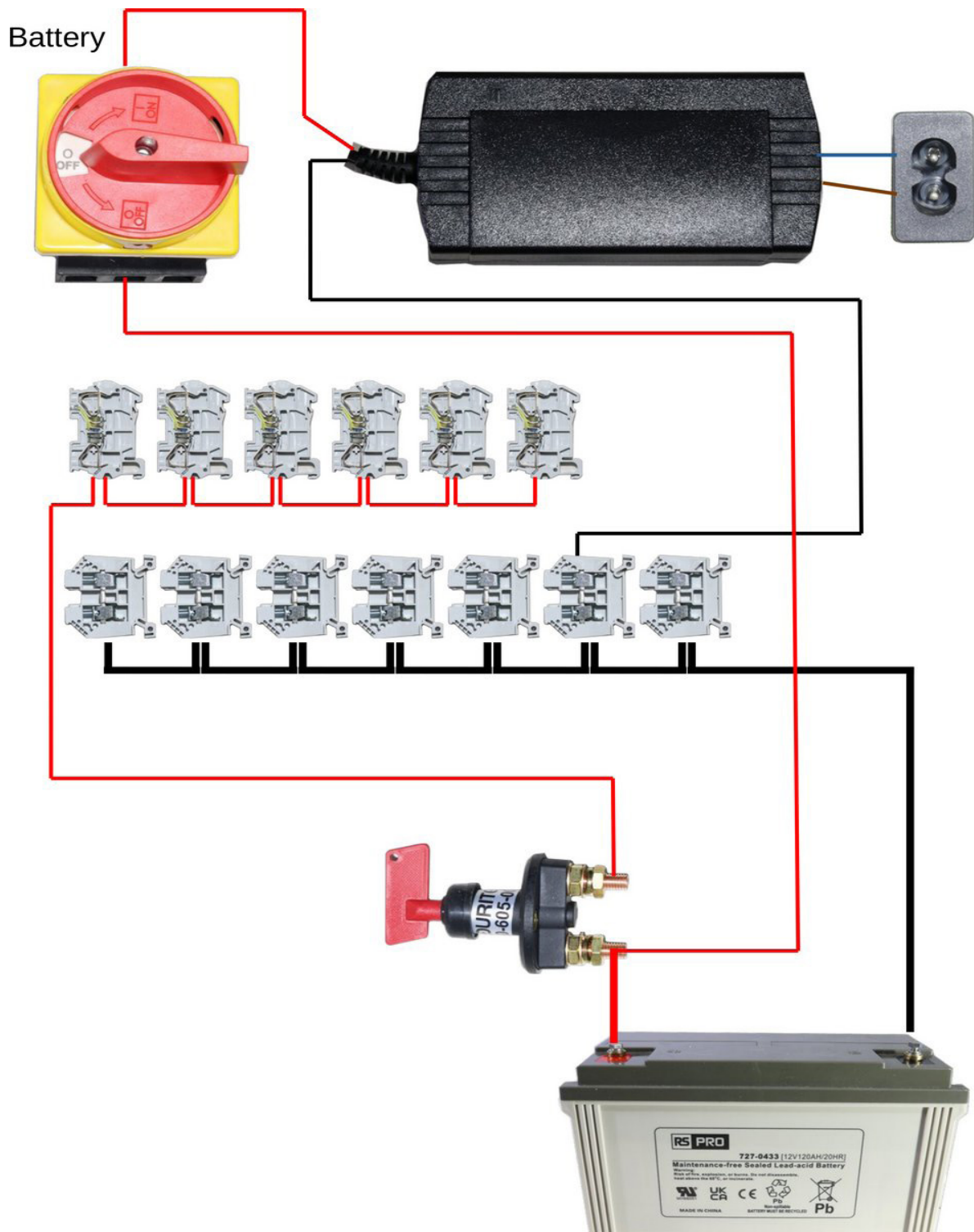

# WIRING - ADDITIONAL FEATURES

Ground is connected to pin 1 of the voltmeter, the positive pole of the battery is connected to pin 4 of the voltmeter via the rocker switch.

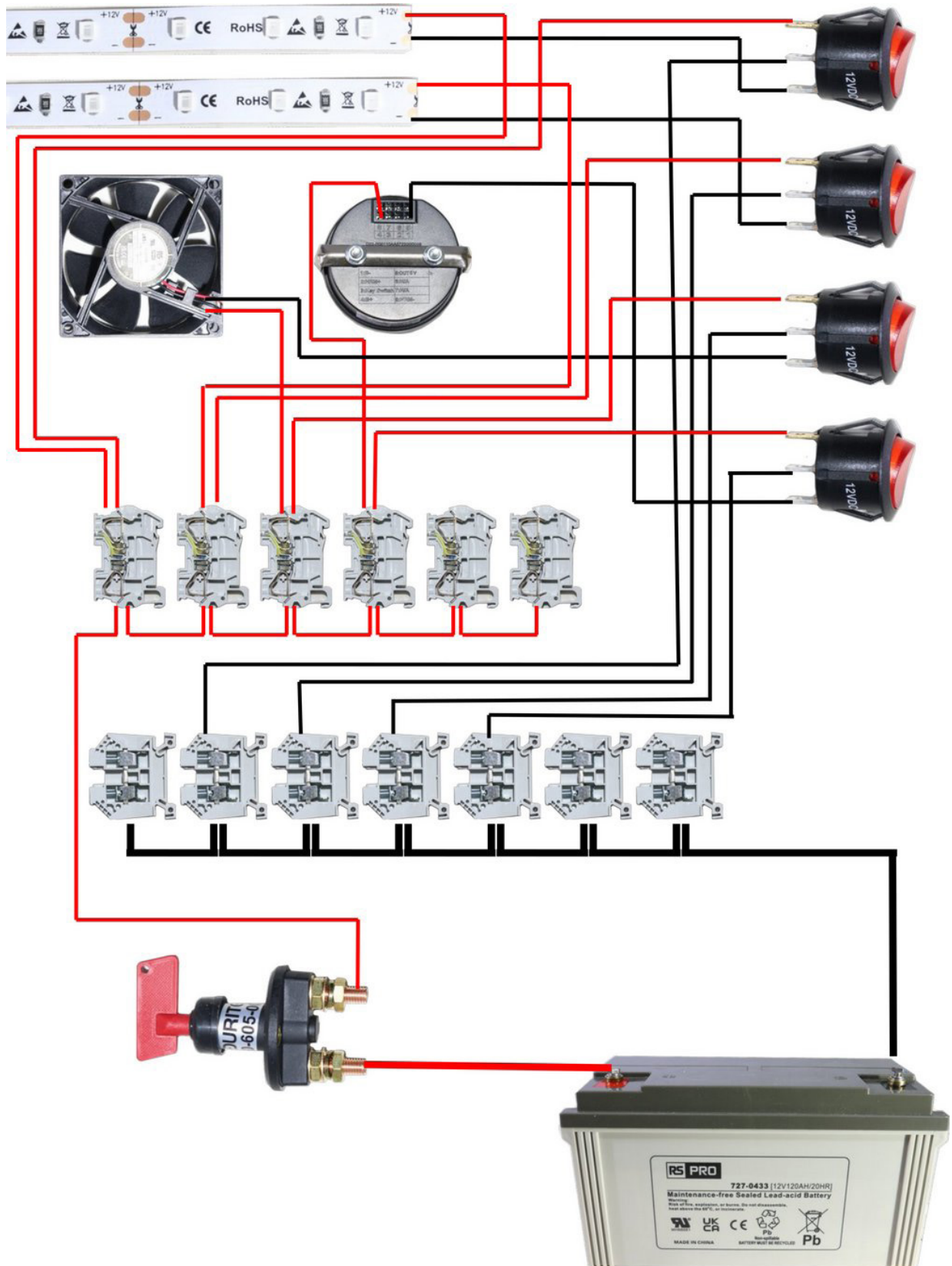

# WIRING - INVERTER 230V

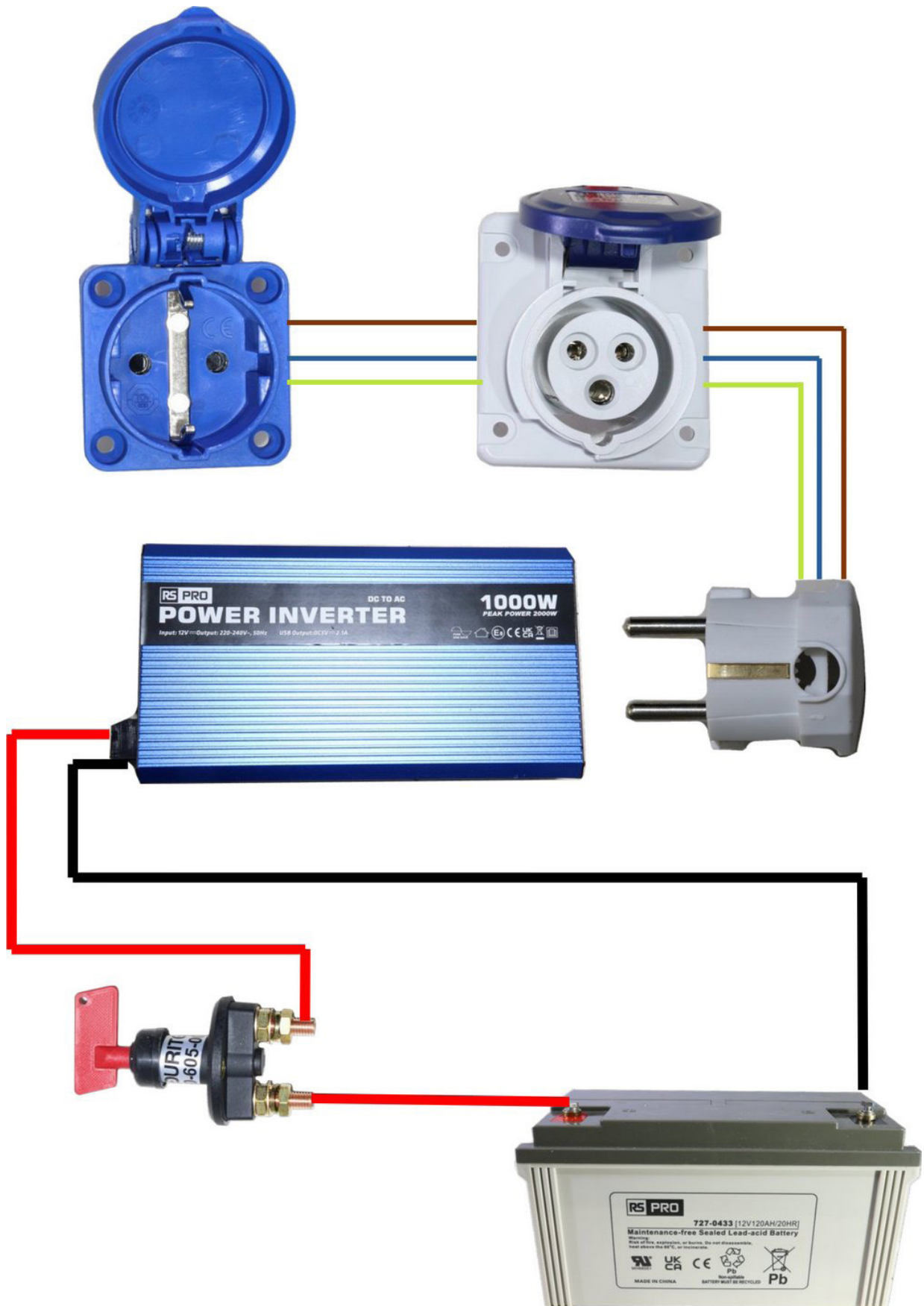



# CONNECTION OF THE BATTERY

## Ref. Description

A 1x 727-0433 Sealed lead acid battery, 12V 120Ah

**Before installing or removing the battery, set the isolator switch to the "OFF" position!**

To install the battery, the rear panelling must be removed. Then the U-shaped subframe can be unscrewed (screws left and right in the cube connectors).

Now insert the battery and assemble the subframe again.

The cable lugs can then be screwed to the battery terminals. **When doing this please ensure the correct polarity! (Red cable to positive, black cable to negative).**

Finally, the rear panelling can be screwed back on.

The solar generator is ready for use when the isolating switch is set to the "ON" position.

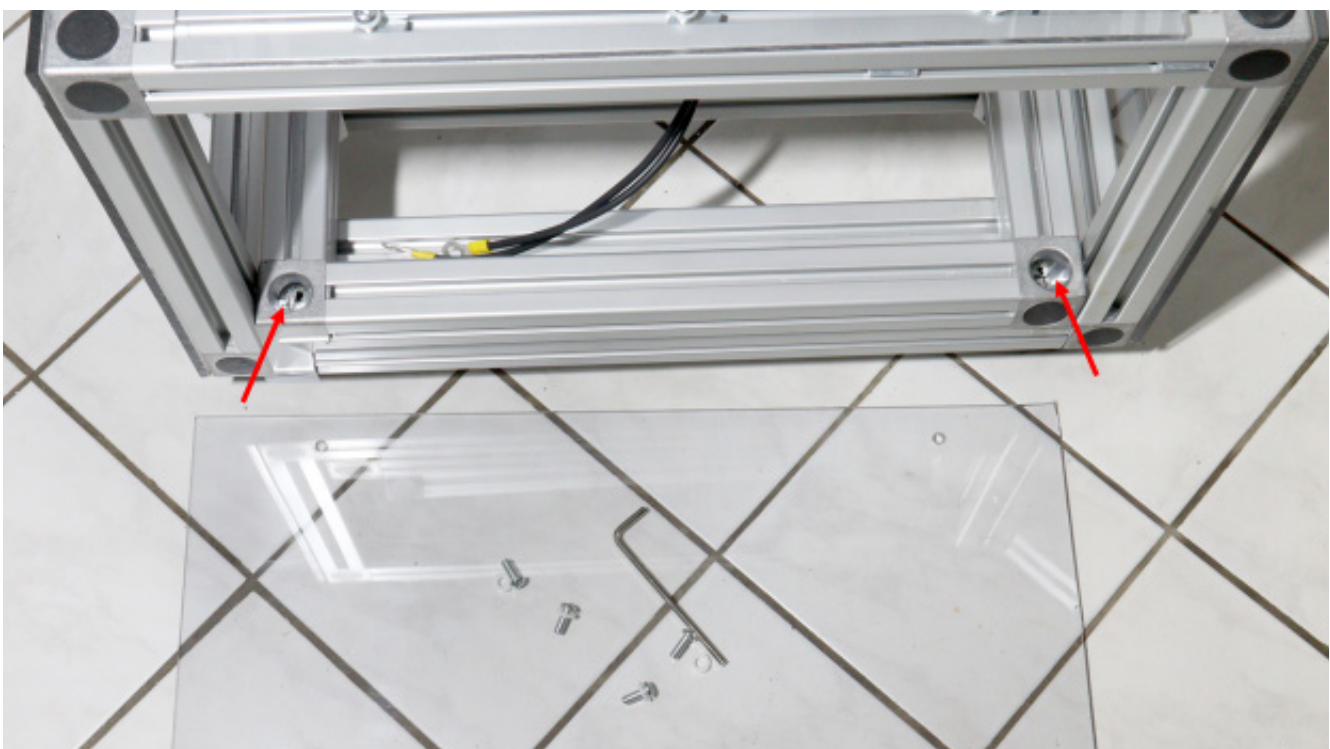

# CONNECTION OF THE BATTERY

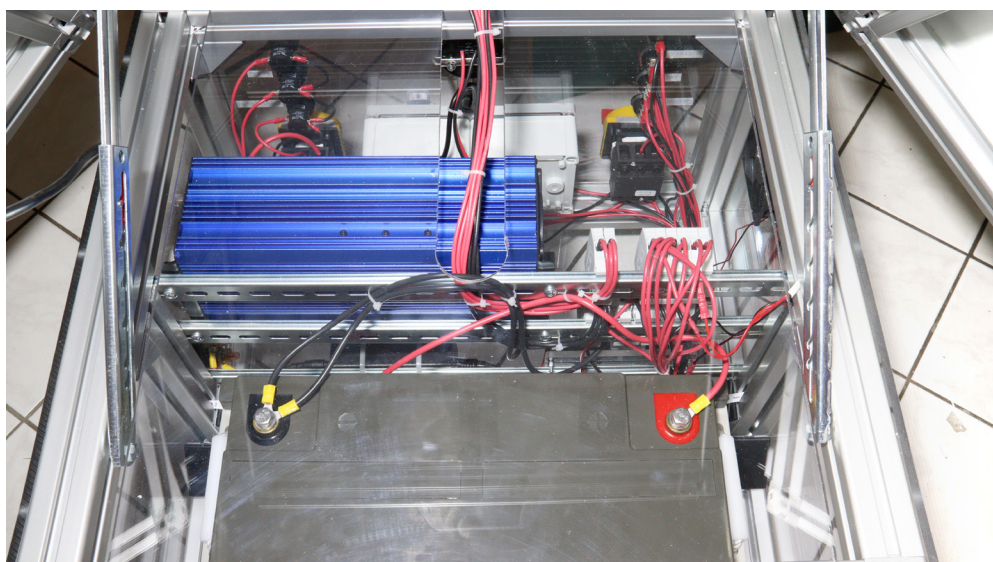
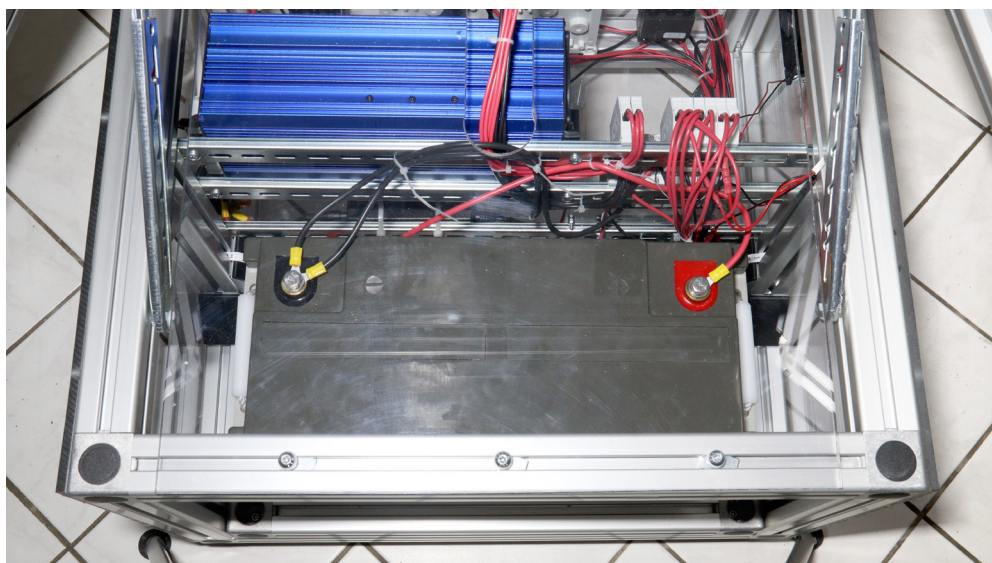
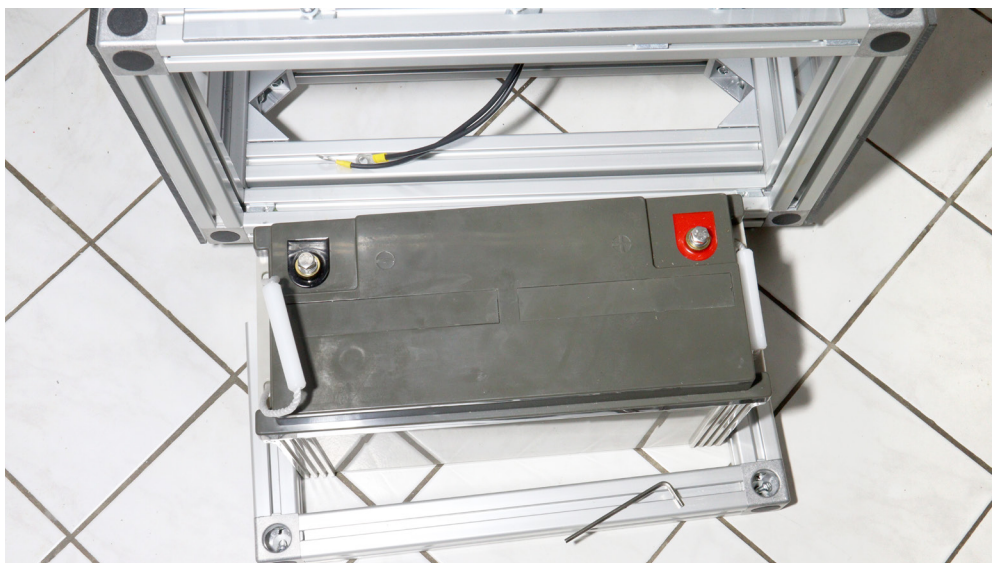



# COMMISSIONING

To unfold the solar panels, first fold the left and right panels upwards using the handles. Tighten the screws of the pivot joints so that the panels remain in position. The centre panel can now be set up using the plastic handle.





# COMMISSIONING

The battery isolator switch on the right-hand side of the box can now be switched on (horizontal position).

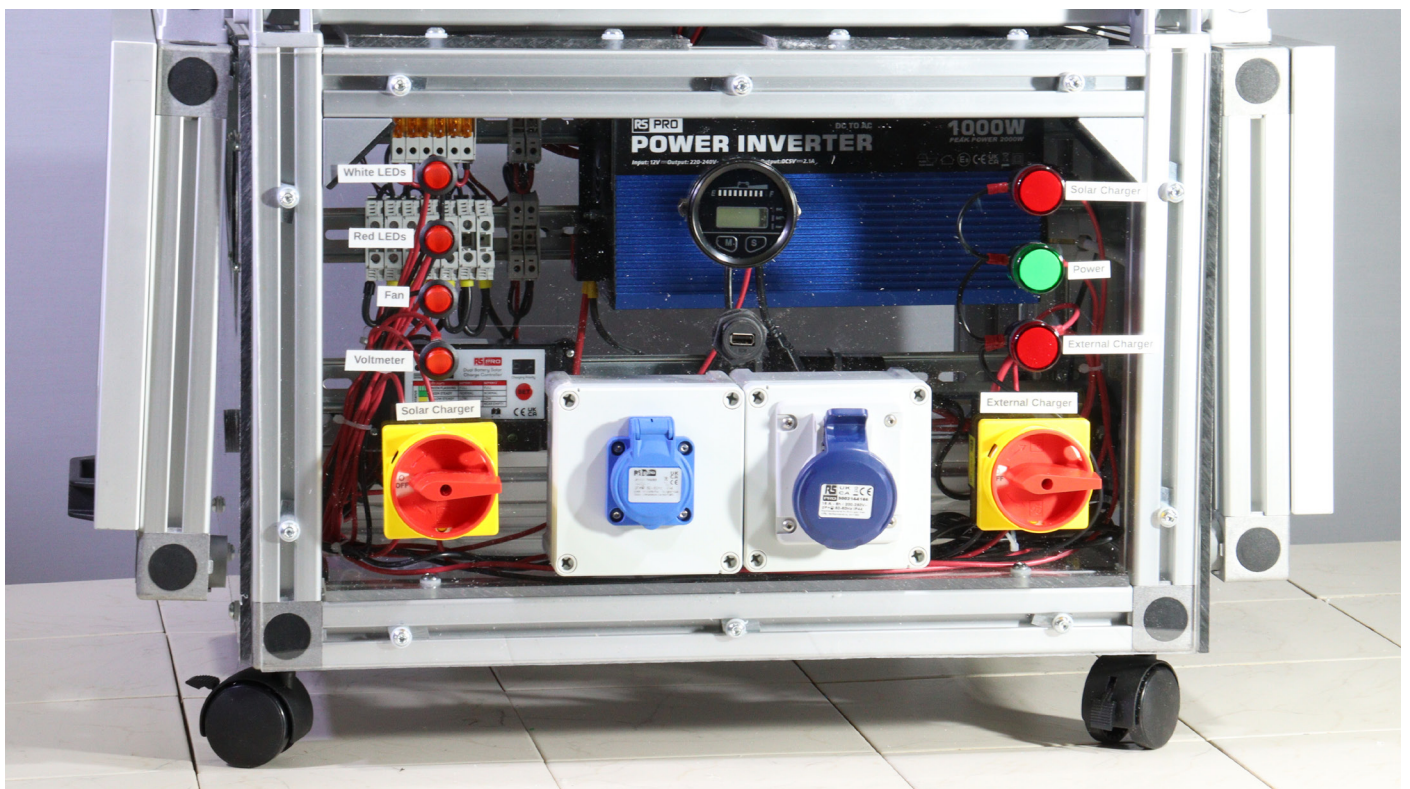

# COMMISSIONING

**The right isolator switch on the front panel should be set to “OFF” when the generator is in operation.**

Otherwise, the inverter may go into error mode (red LED on the inverter).

The solar charger can be switched on using the left isolator switch.

If the battery is sufficiently charged, devices can be connected and operated via the two 230V outlet sockets. The total power of the connected devices must not exceed 1000W.

**Please note that the switch on the inverter must be in the “ON” position!**

The LED stripes (white and red), a fan and the voltmeter can be switched on and off via the left rocker switches.

**Charge the battery using the built-in charger:**

To charge the battery, the battery isolating switch on the right panel of the box should be set to “OFF” position. This disconnects all consumers from the battery.

The right isolator switch on the front panel of the charger can now be set to “ON” and the charger can be connected to the mains via the IEC socket on the right panel of the box.