



DOUBLE CONTOUR HANGER

ASSEMBLY INSTRUCTIONS



DOUBLE CONTOUR HANGER Recommended Tools

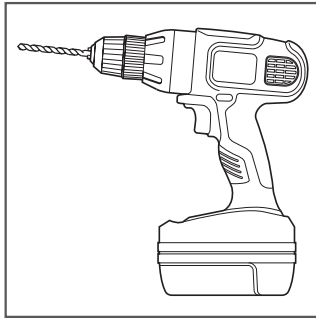

Drill with 1/8", 1/4", and 3/8"
Drill Bits, 1-1/8" Forstner
Bit or 1-1/8" Spade Bit, and
Phillips Bit

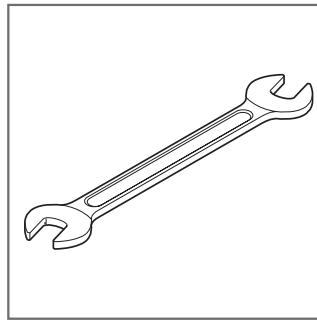

9/16" and 5/8"
Combination Wrench

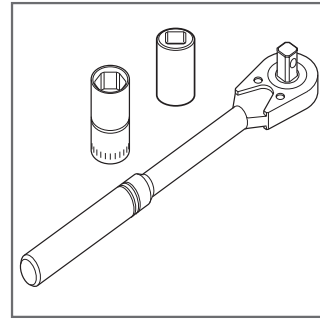

Socket Wrench with
9/16" and 5/8" Sockets

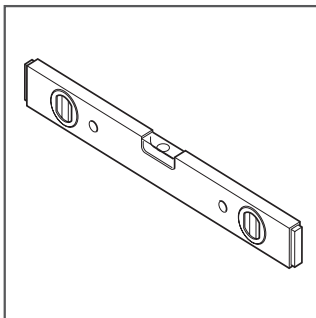

Level

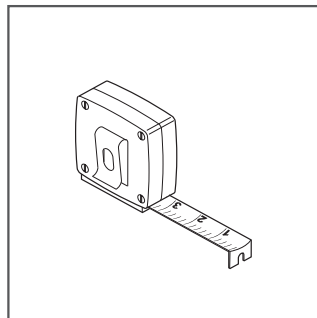

Tape Measure

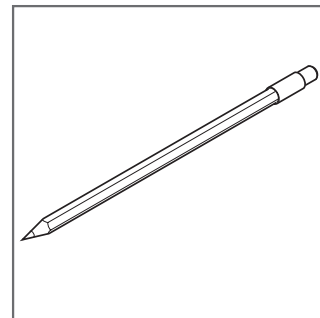

Pencil

DOUBLE CONTOUR HANGER Specifications

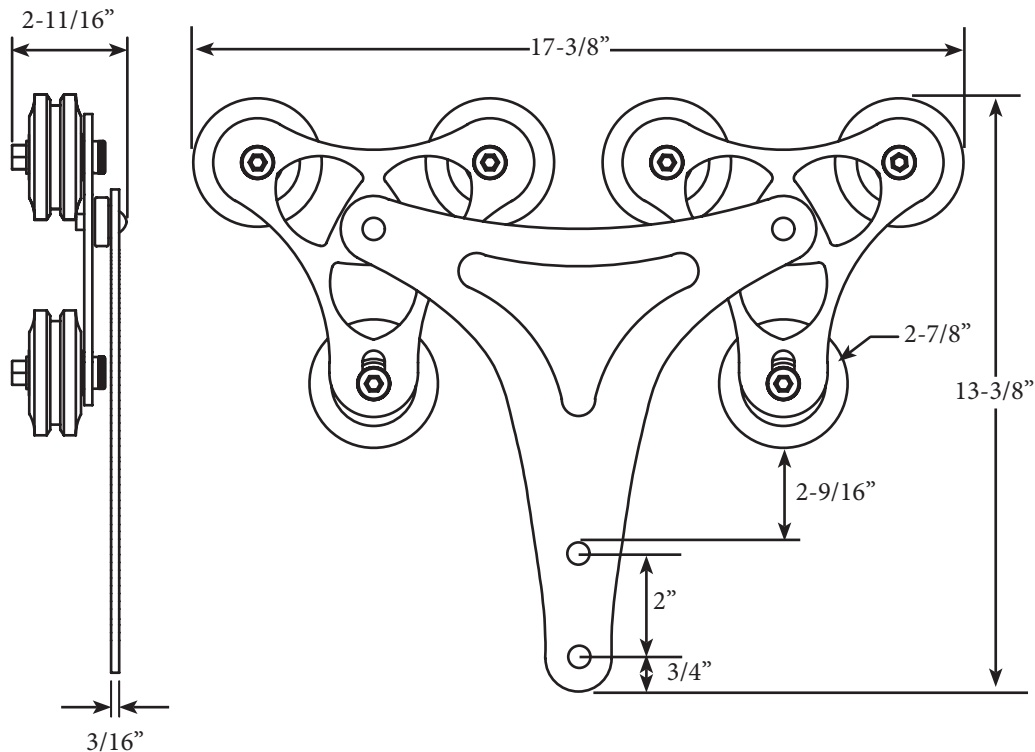

DOUBLE CONTOUR HANGER Parts

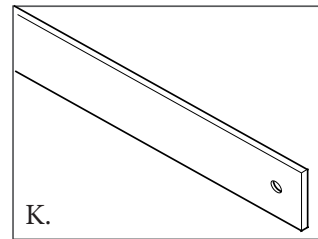
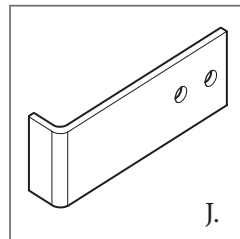
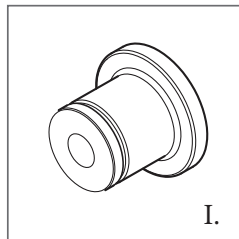
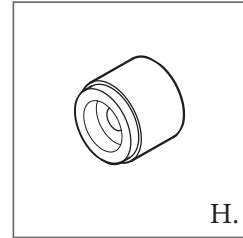
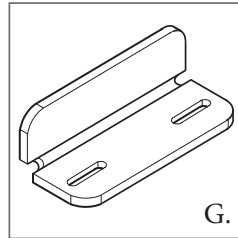
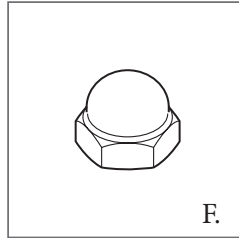
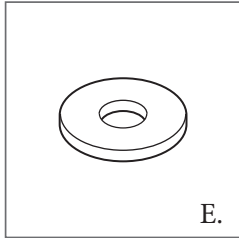
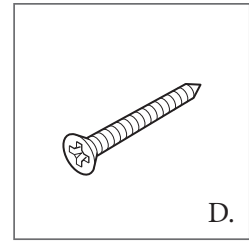
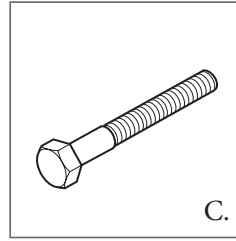
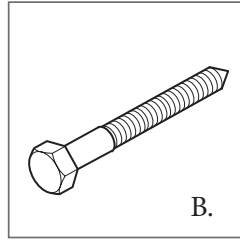
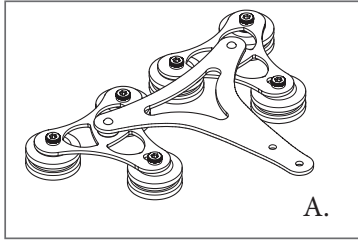

- PARTS
- A. Hanger Assembly
 - B. Lag Screw
 - C. Hex Bolt
 - D. Phillips Head Screw
 - E. 1" Washer
 - F. Acorn Nut
 - G. Door Guide
 - H. Soft Stop
 - I. Spacer
 - J. Anti-Jump Bracket
 - K. Track

**USE TEAMWORK - WE RECOMMEND
TWO PEOPLE FOR THIS BUILD.**

DOUBLE CONTOUR HANGER Assembly Instructions

NOTE:

Doors using Floor Mount Door Guides will have a groove on the bottom. Ensure this groove is on the opposite end of the Door Hanger Installation.

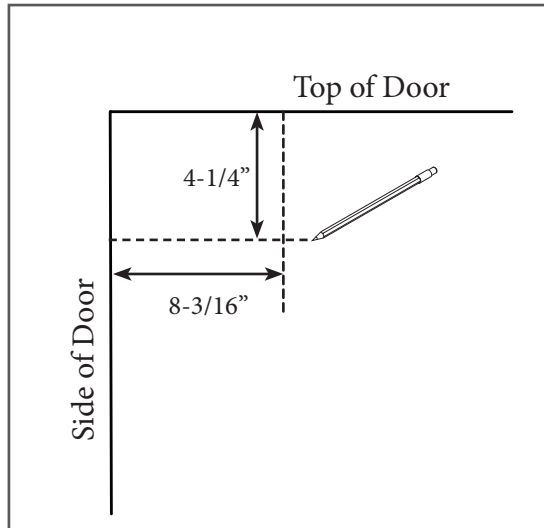
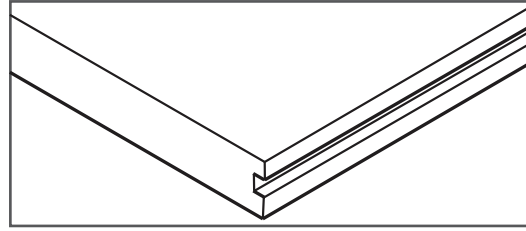

Figure 1

1. Lay the door face up on a smooth, level surface. Measure and mark 8-3/16" from the side edge of the door. Measure and mark 4-1/4" from the top edge of the door ensuring lines from both measurements intersect (Figure 1).

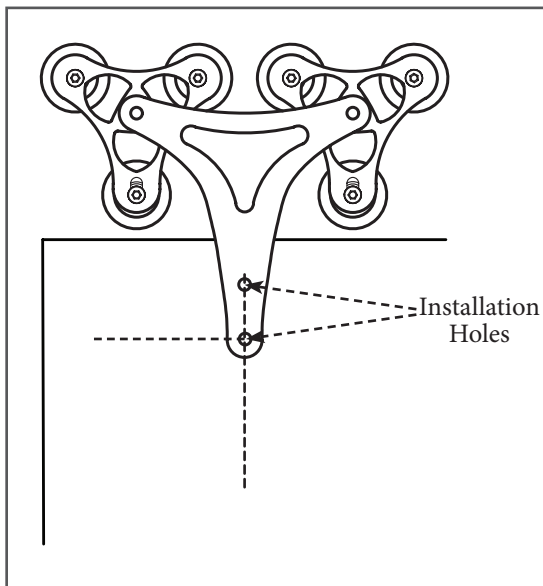

Figure 2

2. Place the hanger on the front of the door facing up with the lower installation hole over the intersecting mark (Figure 2).

3. Repeat steps 1 and 2 for the opposite end of the door. Set the hangers aside.

DOUBLE CONTOUR HANGER Assembly Instructions

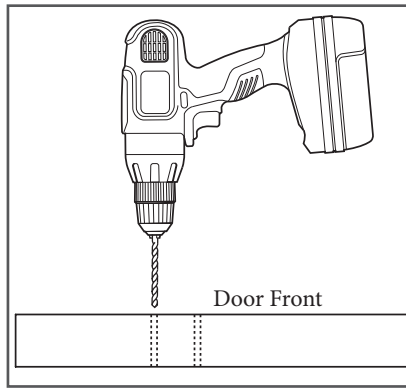

Figure 3

6. Drill two pilot holes all the way through the door for each hanger using a drill with an 1/8" drill bit (Figure 3).

7. Turn the door over. Using a 1-1/8" Forstner bit*, drill a 7/16" deep hole into each pilot hole (Figure 4).

*A 1-1/8" Spade bit may be used in place of a Forstner bit.

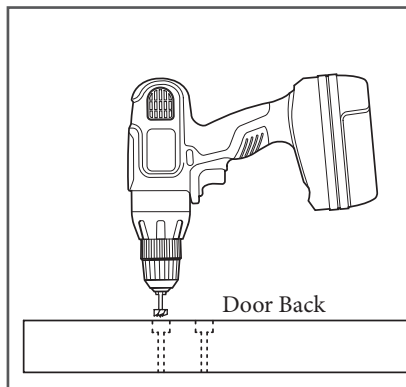

Figure 4

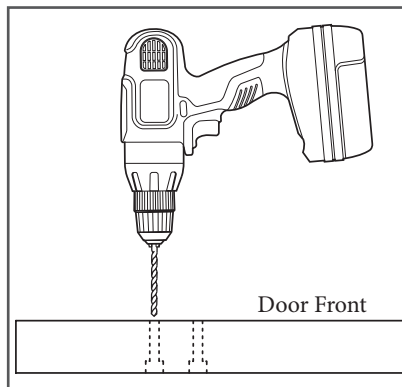

Figure 5

8. Turn the door over, returning it to the face-up position. Drill all the way through the pilot holes using a drill with a 3/8" drill bit (Figure 5).

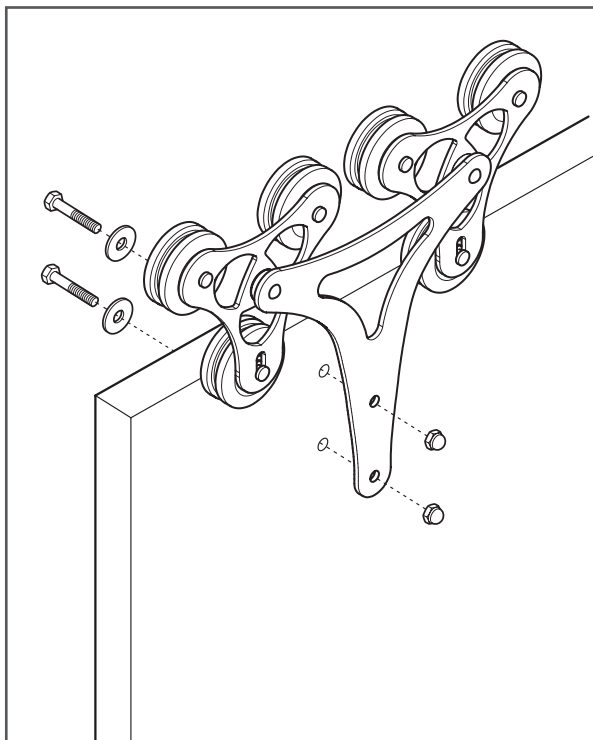

Figure 6

9. Install the hangers to the front of the door using hex bolts, washers, and acorn nuts (provided) (figure 6).

DOUBLE CONTOUR HANGER Installation Instructions

FIRST THINGS FIRST

Check to see if the floor below the track area is level. If the floor rises more than 1/2" the door may rub or not slide open completely. If the floor is not level, measure from the highest point of the floor surface to the recommended track placement and adjust track placement accordingly.

Ensure the track will be installed onto wall studs. If wall studs are not lining up with the installation a header will be required to provide the necessary strength and stability for the track and door.

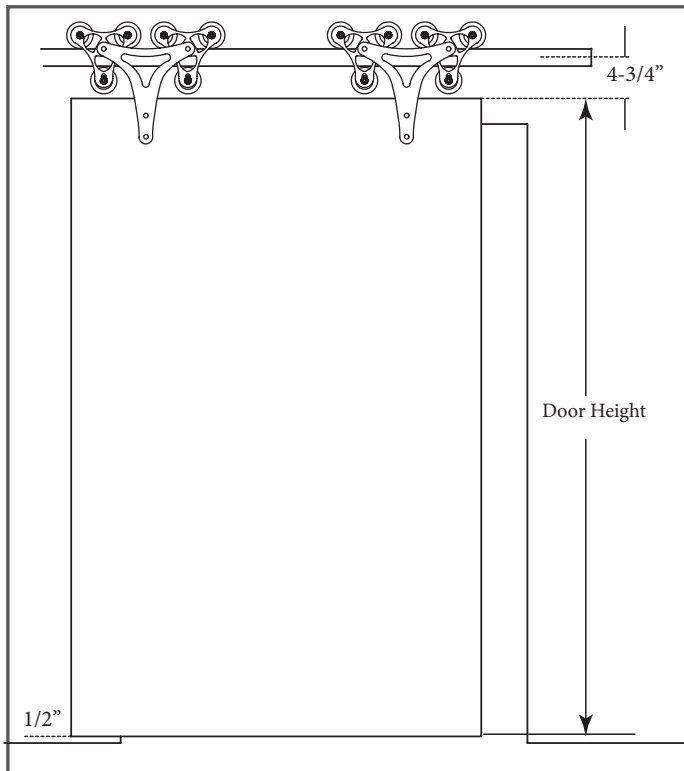

Figure 1

TRACK & DOOR INSTALLATION

1. To determine where the track should be installed, first measure the height of the door, then add 5-1/4" to the door height. 1/2" will be for the clearance between the bottom edge of the door and the floor. 4-3/4" will be from the top edge of the door to the center of the track. (Figure 1).

2. Using a level and a pencil, make a line above the doorway the same length as the track.

3. Hold the track up to where the pencil line is visible through the holes in the track (Figure 2).

SUGGESTION:
Use pieces of double stick tape on the back of the track to help hold the track in place while completing steps 2 and 3.

4. Mark an intersecting line in the center of each track hole (Figure 2).

5. Take the track down, remove double stick tape (if used) and set the track aside.

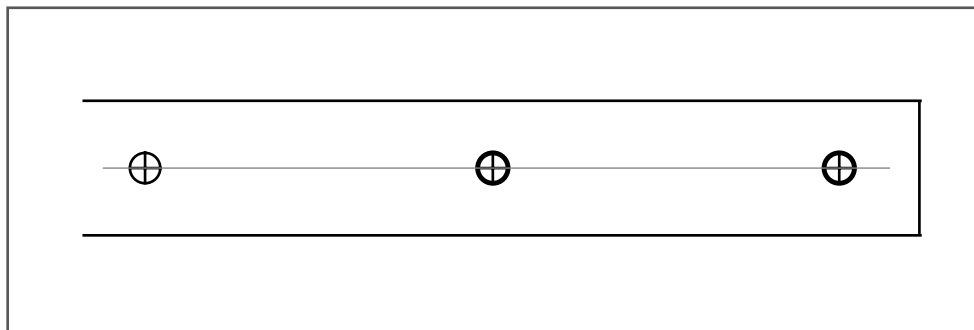

Figure 2

DOUBLE CONTOUR HANGER Installation Instructions

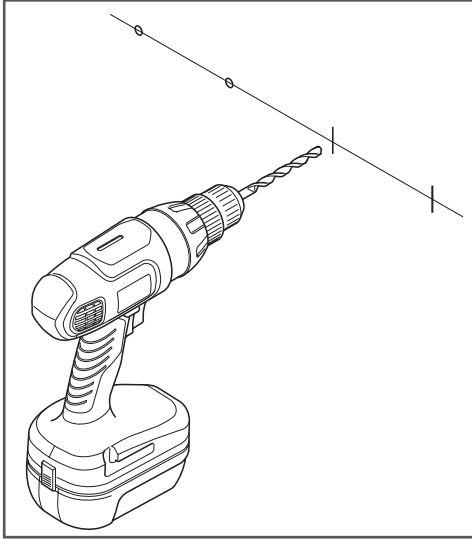

Figure 3

6. Drill out the marked holes using a drill with a 1/4" drill bit (Figure 3).

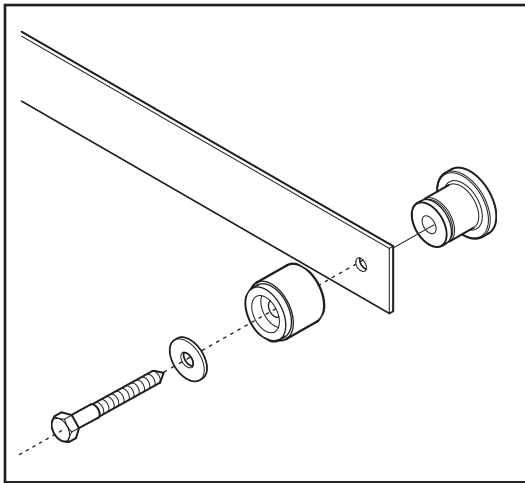

Figure 4

7. Attach one end of the track to the wall with one soft stop, one lag screw, and one washer (provided) using a socket wrench with 9/16" socket (Figure 4). Do not tighten.

8. Repeat step 7 for the other end of the track.

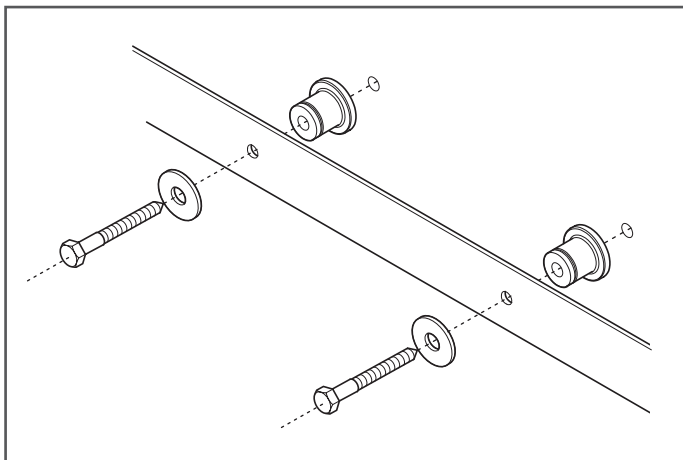

Figure 5

9. Install remaining spacers with lag screws and washers (provided) using a 9/16" socket wrench (Figure 5). Tighten all lag screws.

DOUBLE CONTOUR HANGER Installation Instructions

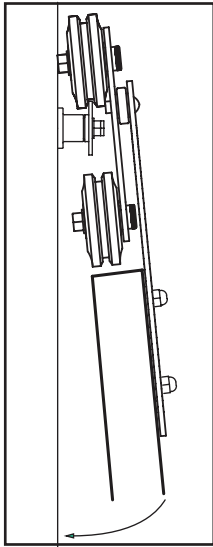

Figure 6

11. Hang the door, ensuring that all eight (8) wheel grooves have contact with the track (Figure 6).

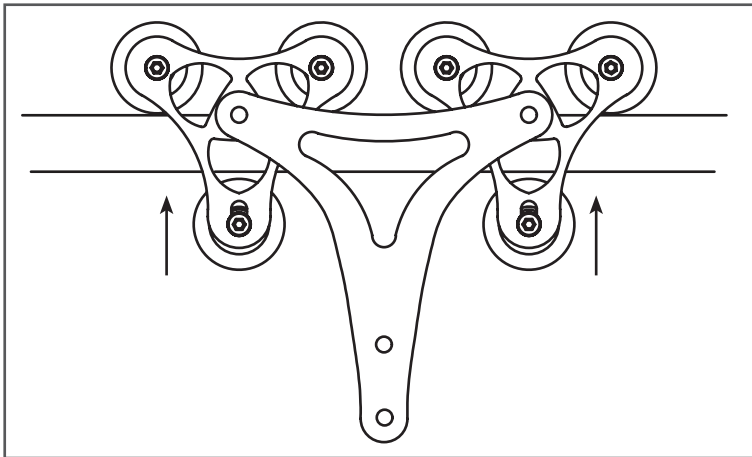

Figure 7

12. Adjust the lower wheels by loosening the nuts on the wheel and sliding the wheel up until the interior groove makes contact with the track. Tighten the nuts (Figure 7).

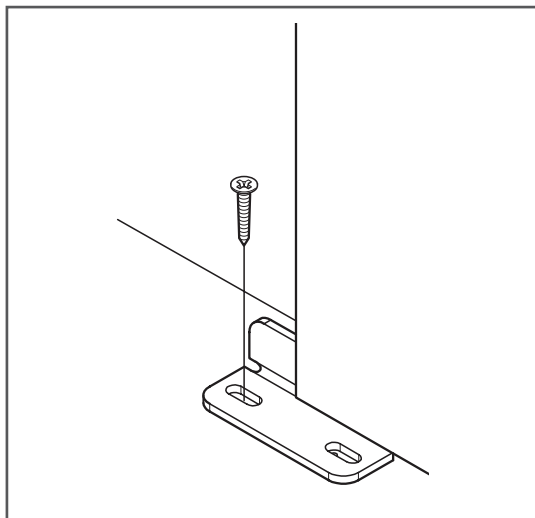

Figure 8

DOOR GUIDE INSTALLATION

13. With the door in the closed position, ensure the door is hanging straight using a bubble level.

14. Position the Door Guide part way into the groove in the bottom of the door (Figure 8).

SUGGESTION:
Use double stick tape on the bottom of the door guide to hold the guide in place.

DOUBLE CONTOUR HANGER Installation Instructions

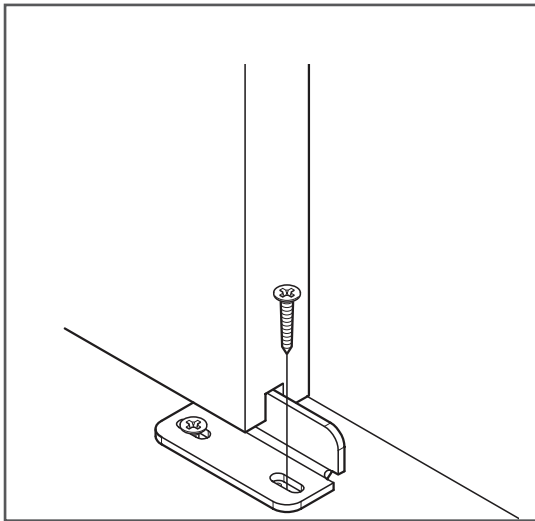

Figure 9

15. Install the Door Guide using a 1" phillips screw (provided) and a drill with a phillips bit.

16. Slide the door toward the open position until the other side of the Door Guide is exposed.

17. Install the second 1" phillips screw (provided) using a drill with a phillips bit (Figure 9).

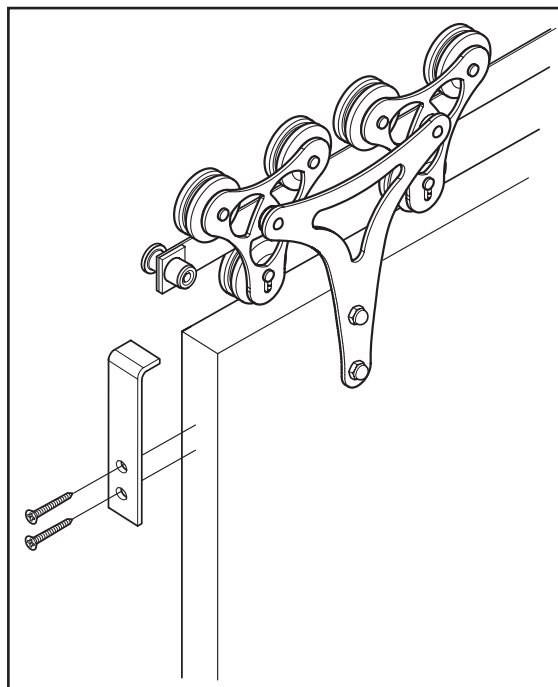

Figure 10

ANTI-JUMP GUIDE INSTALLATION

18. Place the Anti-Jump bracket on the door side, moving the bracket up until it is between 1/8" and 1/16" from the bottom edge of the rail. Mark the placement with a pencil.

SUGGESTION:

Use double stick tape on the back of the anti-jump bracket to hold it in place on the door.

19. Install the bracket to the door edge with 2 phillips screws (provided) using a drill with a phillips bit (Figure 10).

20. Repeat steps 18 and 19 for the opposite end of the door.

WE LOVE WHAT YOU ARE DOING WITH THE PLACE

CONGRATULATIONS ON YOUR DECISION TO BRING HOME
AN AMERICAN MADE PRODUCT OF THE HIGHEST QUALITY.
WE HOPE YOUR DOUBLE CONTOUR HANGER BRINGS ART AND FUNC-
TION INTO YOUR LIFE.

DESIGNED AND CRAFTED
ENTIRELY IN THE

U.S.A.



DON'T BE A STRANGER. FOLLOW US
ON SOCIAL MEDIA.



support@rusticahardware.com