

Z Combination Door

Assembly Instructions



Assembly Instructions

Tools Needed

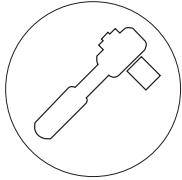

Ratchet with socket

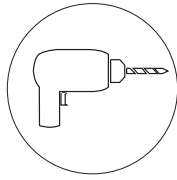

Drill with Phillips bit

If any of the slats have been damaged during shipping, call us at 800-891-8312 and we will expedite a replacement slat. Lay out your Door parts according to the illustration shown below to accurately identify which part needs to be replaced, if any.

Lay all parts out on a flat surface as shown here.

PLEASE NOTE: These instructions are specific to a particular door size and type. Adjustments may be needed on your part for changes in specifications and measurements, as well as door types that are different from these.

Parts Included

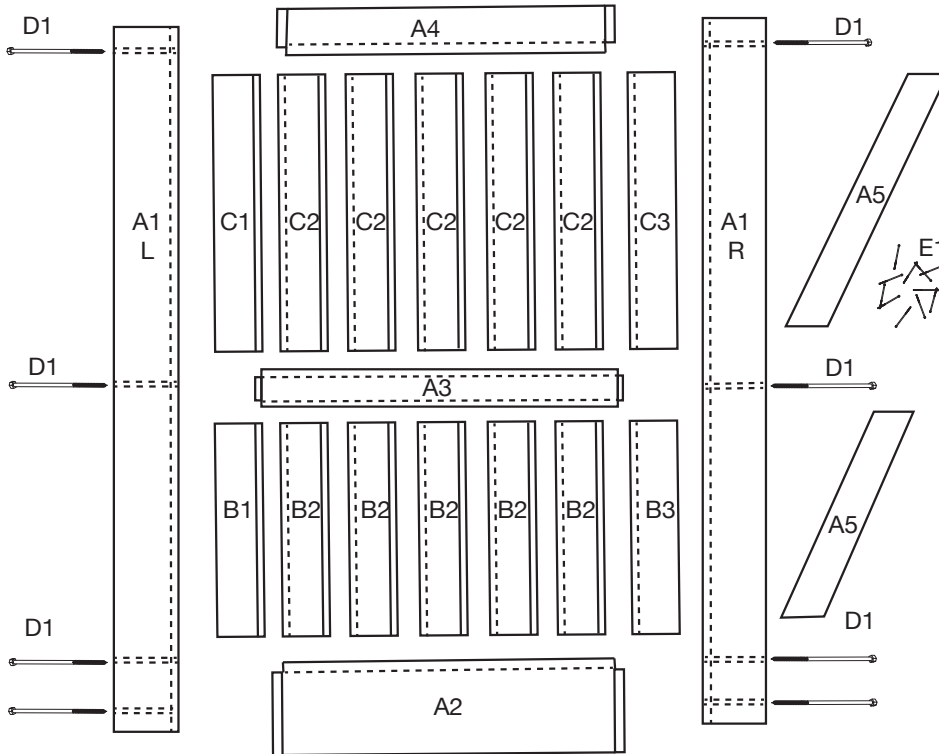

	Description	Qty
A1 L	Side Stile Left	1
A1 R	Side Stile Right	1
A2	Bottom Rail	1
A3	Middle Rail	1
A4	Top Rail	1
A5	Diagonal Rails	2
B1, C1	Outer Slats, lower	1 ea
B2, C2	Tongue & Groove Slats	1 ea
B3, C3	Outer Slats, upper	6 ea*
D1	6" Lag Bolts	6*
E1	1-1/4" Grabber Screws	13*

* Quantities will vary depending on Door size. All quantities in this table are for an average-size single Door order.



Assembly Instructions

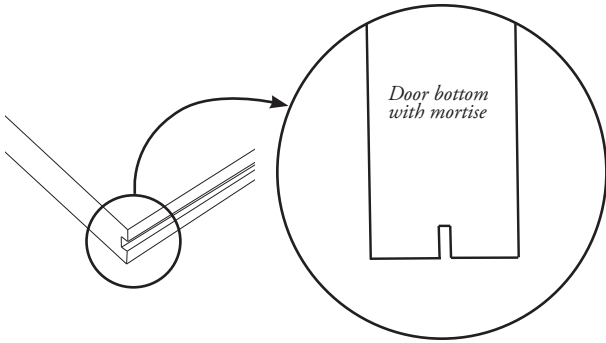

NOTE: If you are installing a Floor Mount Door Guide, your door will have a mortise (a groove that runs along the bottom of your door). Make sure this mortise is facing down towards your floor and that you install the Door Hangers on the other end.

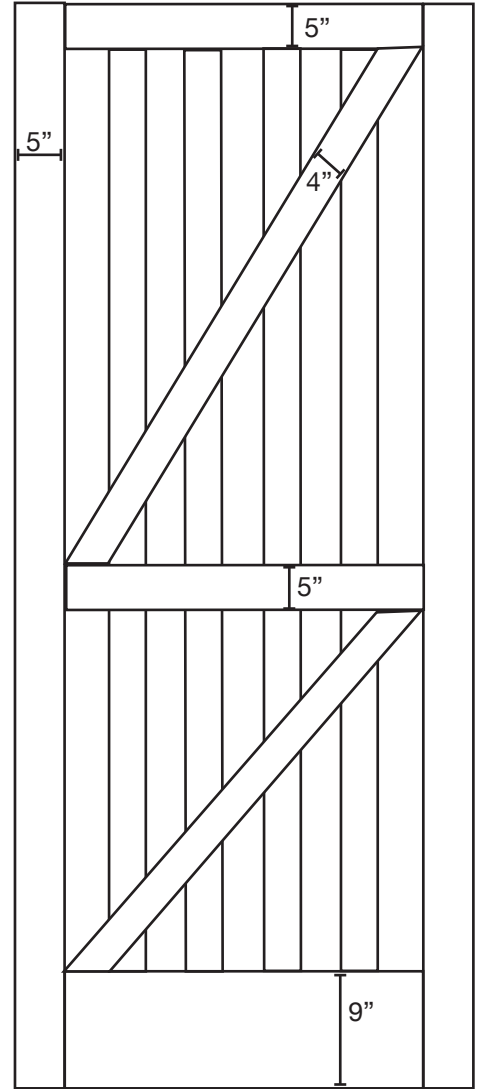

Assembly Instructions

Assembling Your Door

We recommend a dry assembly. It is recommended you not use glue or adhesive of any kind.

1. Lay out A1 R and A2 Bottom Rail. Square the sides with the bottom, then fasten them together with a 6" Lag Bolt (D1). Have someone help keep the door square as you attach with the Lag Bolt, going into the bottom of A1 R and into the Bottom Slat, A2. Have the Lag Bolt go straight in, no angle whatsoever, using your hands first, then a ratchet.

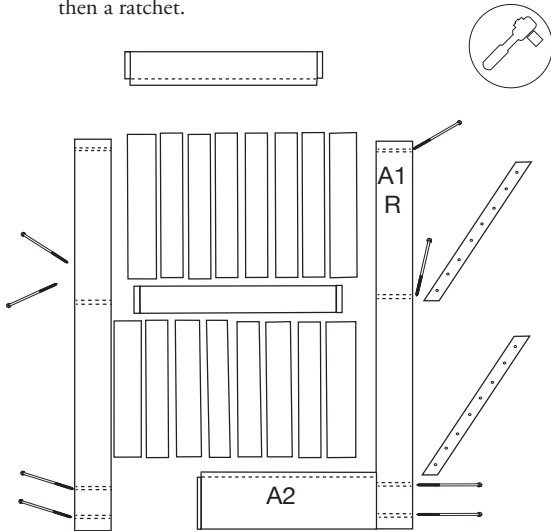

PLEASE NOTE: These instructions are specific to a particular door size and type. Adjustments may be needed on your part for changes in specifications and measurements, as well as door types that are different from these.

2. Slide B1, B2, and B3 slats' tongues into A1 R and A2 grooves.

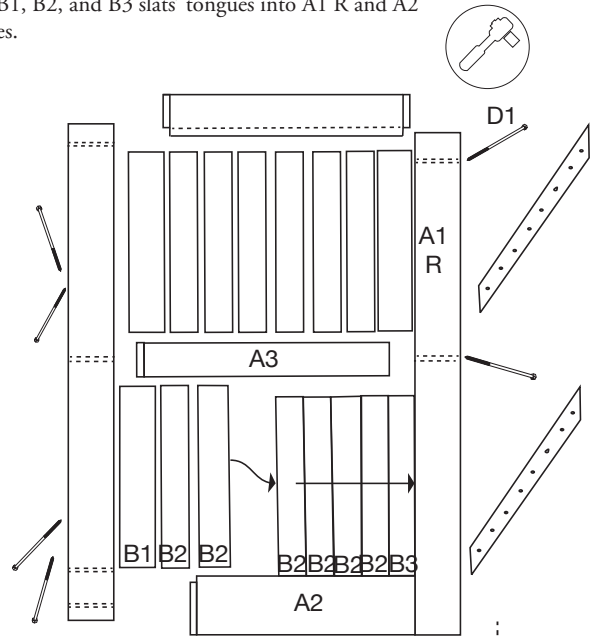

3. Once all of the lower slats have been positioned, place the A3 Center Rail onto the B slats and in the A1 R grooves. Fasten A3 into place with the center Lag Bolt, first with your hand, then tighten with a ratchet.

Next, slide all C Slats down and to the right.

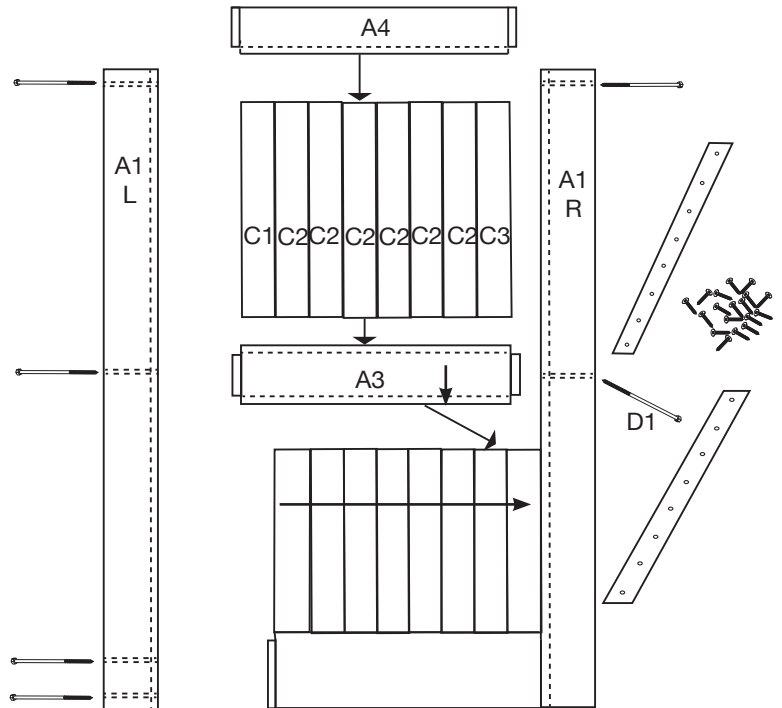

Assembly Instructions

5. Slide Top Rail A4 into place, to cover the tops of the C Slats. Install a Lag Bolt into the top remaining hole on Side Stile A1 R. Tighten by hand then with a ratchet.

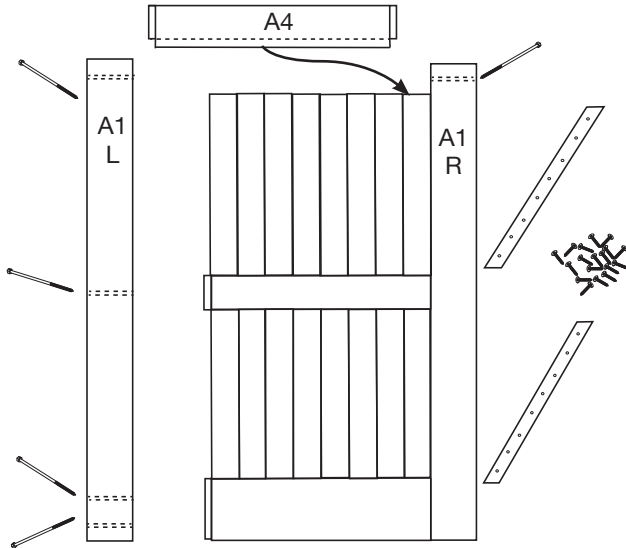

5. Slide Side Stile A1 L into place, attaching with remaining three 6" Lag Bolts, tightening by hand. Once again, have someone help you keep all of the slats straight. Once you have determined all are in place straight, tighten Lag Bolts with a ratchet.

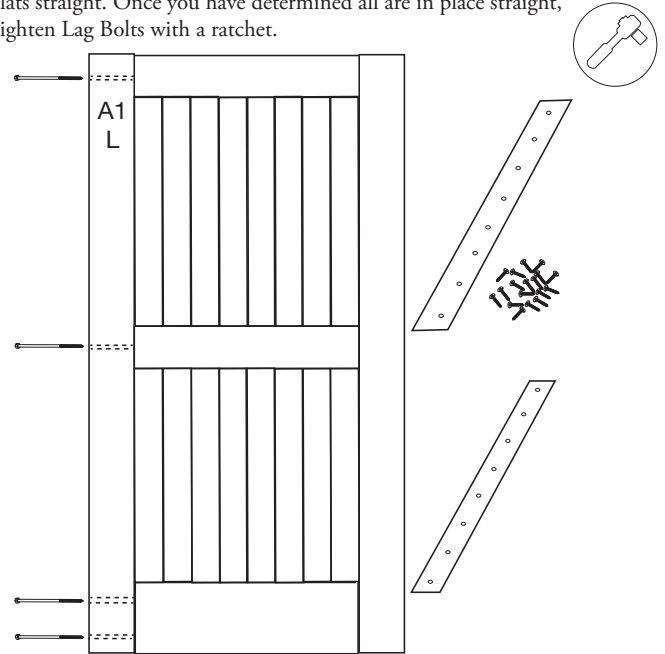

6. When the Door is assembled, place A5 Rails (Diagonal Rails) onto the door so the predrilled holes are facing up and so they run the same way, from corner to corner. Attach using the 1-1/4" Grabber Screws and a drill with a Phillips bit.

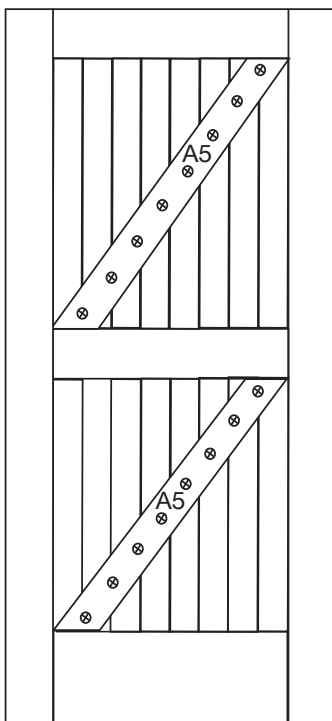

7. Attach the Door Pull of your choice and your Door is ready to hang.

