

# Double X Door

## Assembly Instructions



# Assembly Instructions

## Tools Needed

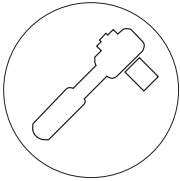

Ratchet with socket

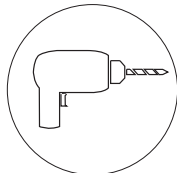

Drill with Phillips bit

If any of the stiles, slats or rails have been damaged during shipping, call us at 800-891-8312 and we will expedite a replacement. Lay out your Door parts according to the illustration shown below to accurately identify which part needs to be replaced, if any.

Lay out all Door parts as shown here.

## Parts Included

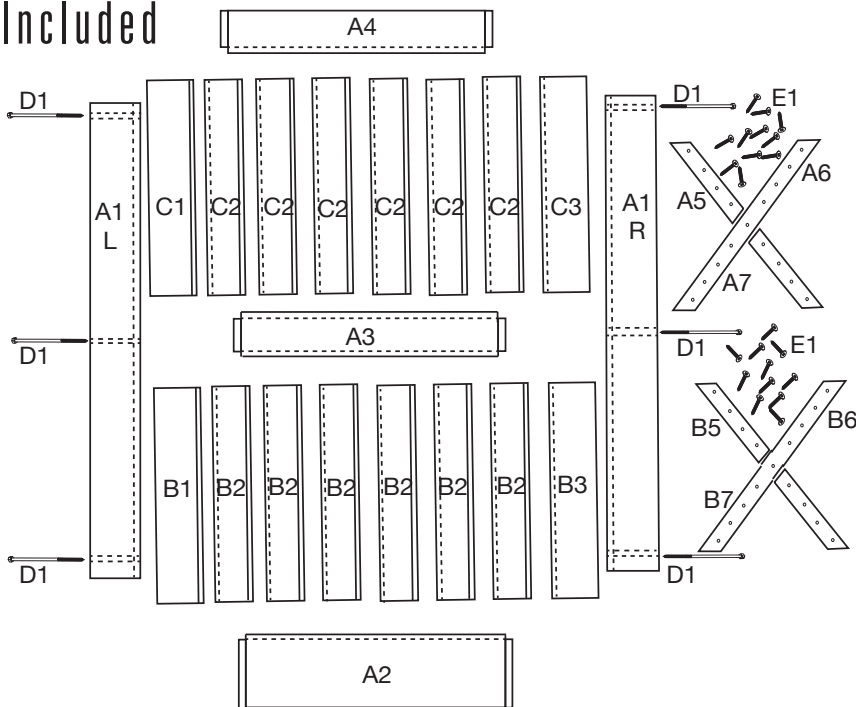

**PLEASE NOTE:** These instructions are specific to a particular door size and type. Adjustments may be needed on your part for changes in specifications and measurements, as well as door types that are different from these.

	Description	Qty		Description	Qty
A1 L	Side Stile Left	1	B1, C1	Left Edge Slats	1 each
A1 R	Side Stile Right	1	B3, C3	Right Edge Slats	1 each
A2	Bottom Rail	1	B2, B3	Upper Tongue & Groove Slats	6 each*
A3	Middle Rail	1	C2, C3	Lower Tongue & Groove Slats	6 each*
A4	Top Rail	1	D1	6" Lag Bolts	6*
A5, A6, A7	Upper Diagonal Rails	1 each	E1	1-1/4" Grabber Screws	varies*
B5, B6, B7	Lower Diagonal Rails	1	E1	1-1/4" Grabber Screws	varies*

\* Quantities will vary depending on Door size.  
All quantities in this table are for an average-size single Door order.



# Assembly Instructions

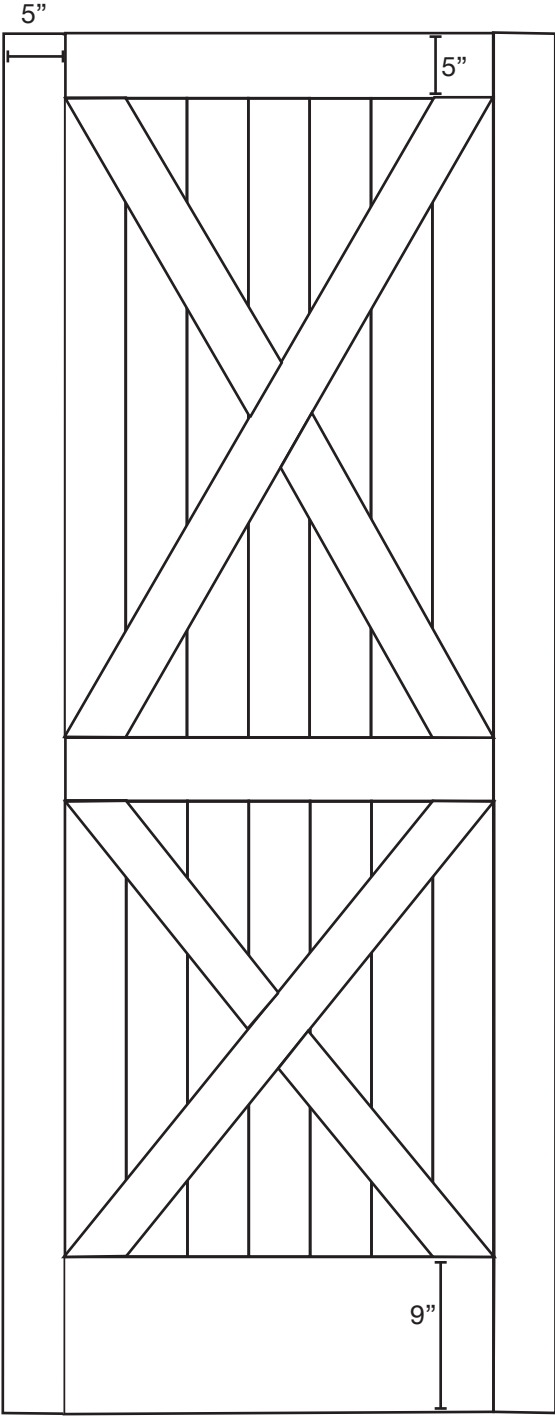

# Assembly Instructions

## Assembling Your Door

We recommend a dry assembly. It is recommended you not use glue or adhesive of any kind.

**PLEASE NOTE:** These instructions are specific to a particular door size and type. Adjustments may be needed on your part for changes in specifications and measurements, as well as door types that are different from these.

1. Lay out all Door parts as shown here. Slide bottom rail A2 so its right end goes into the groove on A1R (stile).

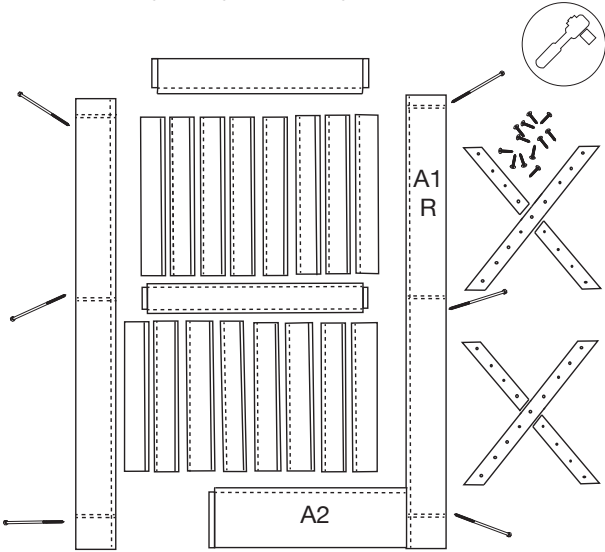

2. Slide B1, B2, and B3 slats' tongues into A1R and A2 grooves.

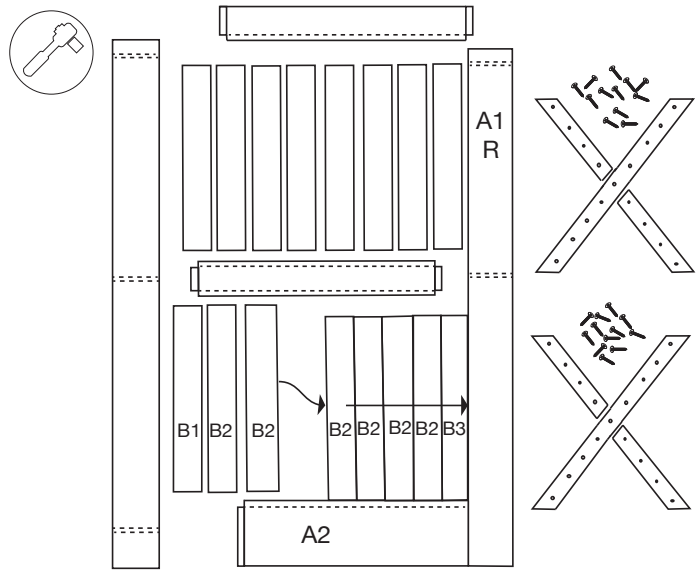

3. Slide all remaining B slats into place. Now slide A3 Middle Rail down the A1 R grooves until it rests on the B Slats. Attach using a 6" Lag Bolt, making sure it is going straight into the predrilled hole, not at an angle. If necessary, have someone help you hold all slats and rails in place while you are fastening the Lag Bolts.

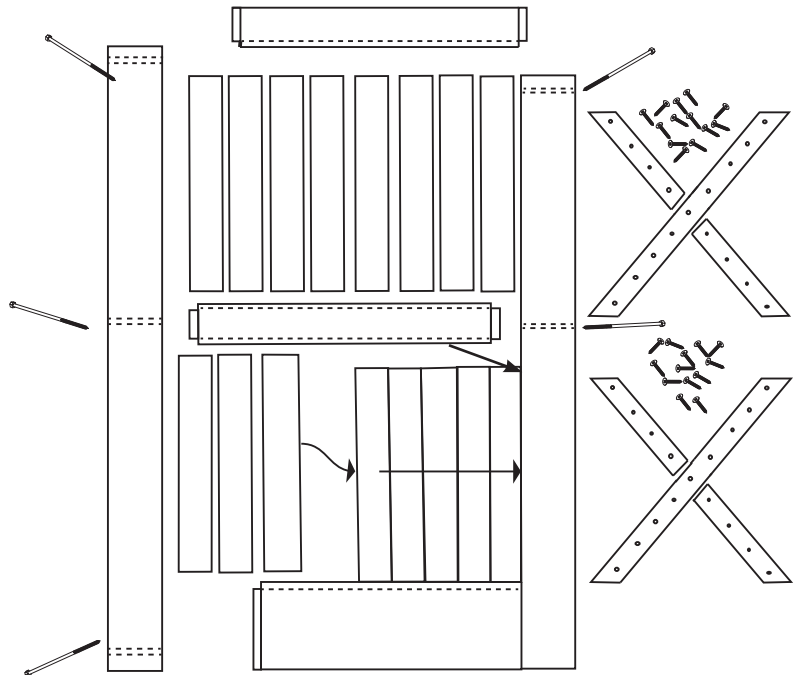

# Assembly Instructions

4. Slide all C Slats into A1 R and A3 grooves. Once all of the slats have been positioned, place the A4 Top Rail onto the C slats and in the A1 R grooves. Fasten A4 into place with a Lag Bolt, first with your hand, then tighten with a ratchet. Be sure the Lag Bolt is going straight in and not at an angle. Fasten by hand, then with a ratchet.

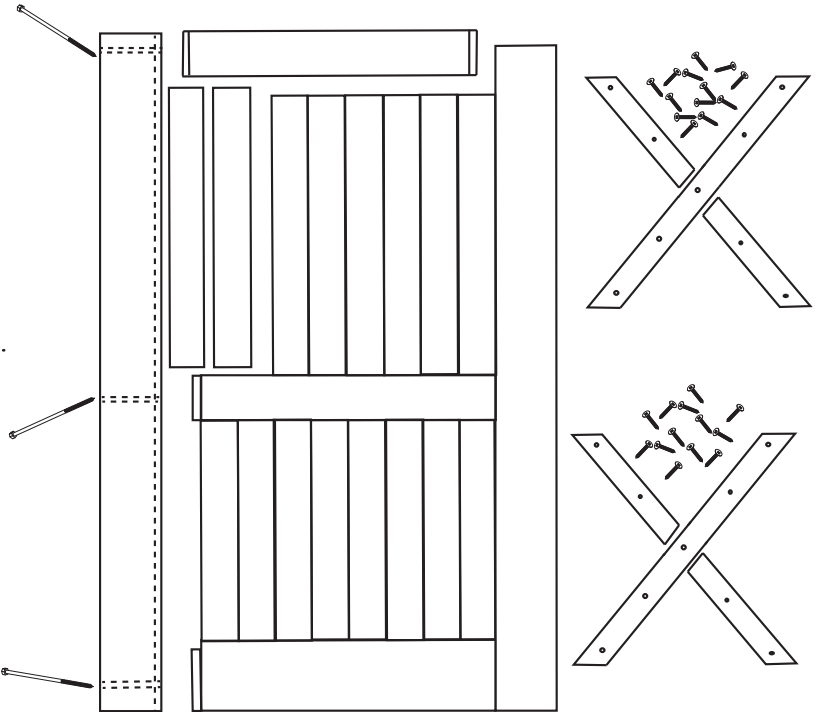

5. Slide Side Stile A1 L into place, attaching with 6" Lag Bolts, tightening by hand. Once you have determined all are in place straight, tighten Lag Bolts with a ratchet.

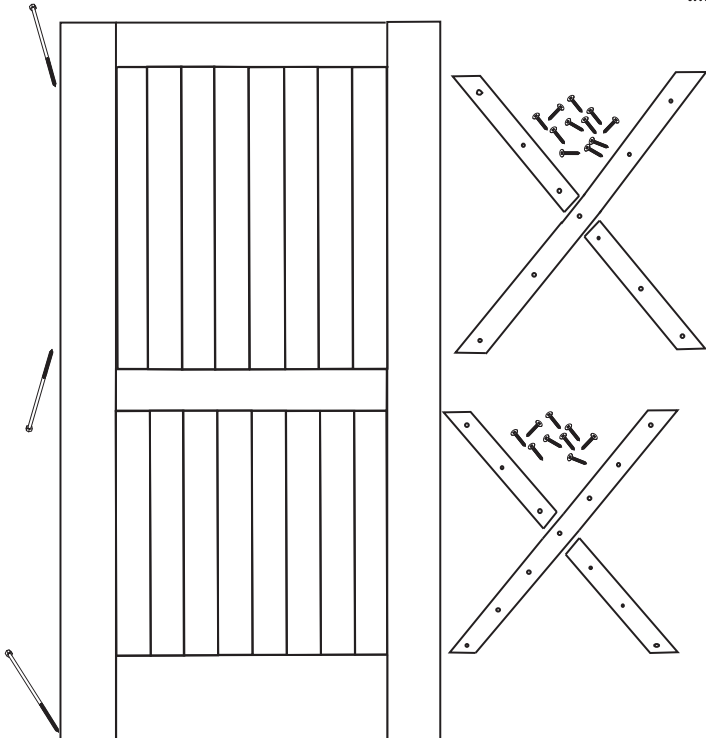

6. When the Door is assembled, place A5, A6 and A7 (Top Diagonal Rails) onto the door so the predrilled holes are facing up and so they form an X that runs from corner to corner. Attach using the 1-1/4" Grabber Screws and a drill with a Phillips bit. Your Door is ready to hang.

Repeat for B5, B6, and B7 (Lower Diagonal Rails).

