

"NO SHOW" BARN DOOR HARDWARE

INSTALLATION INSTRUCTIONS

Bi-Parting or Double Barn
Doors will have extra
steps identified at the end
of the instructions



CONGRATULATIONS ON YOUR DECISION TO BRING HOME AN
AMERICAN MADE PRODUCT OF THE HIGHEST QUALITY.

1-800-891-8312
support@rustica.com
www.Rustica.com

DESIGNED AND CRAFTED ENTIRELY IN THE
U.S.A.



DON'T BE A STRANGER.
FOLLOW US ON SOCIAL MEDIA.



NO SHOW BARN DOOR HARDWARE Installation Instructions

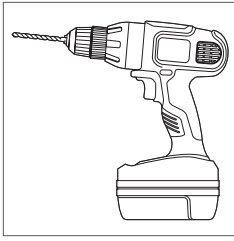

Drill with 3/32",
3/8" and Phillips
Bit or
Screwdriver

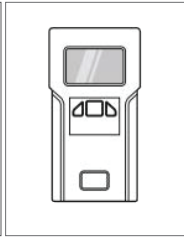

Stud Finder

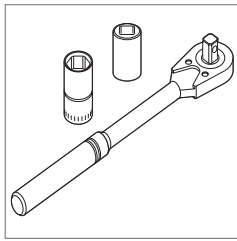

Socket Wrench
with 9/16" & 5/8"
Sockets

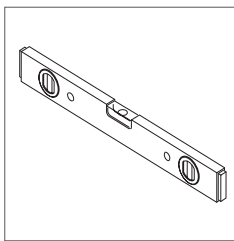

Level

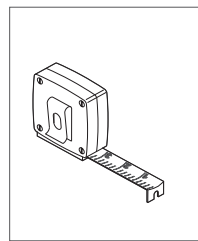

Tape Measure

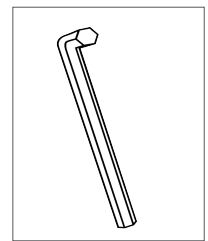

Allen Wrench

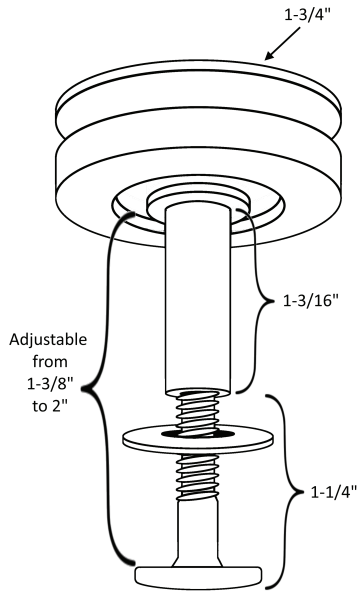

PARTS

- A. Hanger/Wheel Assembly
 - a. Wheel
 - b. Female Bolt
 - c. Washer
 - d. Male Bolt
- B. Lag Screw
- C. Washer
- D. Track
- E. Spacers
 - a. 1/2"
 - b. 3/8"
- F. Anti-Jump Block
& Bi-Parting Stops
- G. Door Stop
- H. Door Guide
- I. Phillips Screw

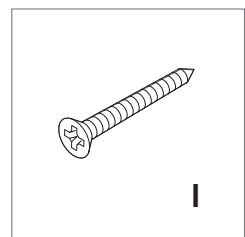
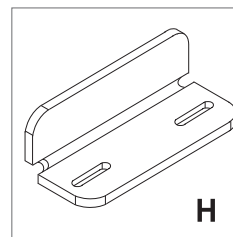
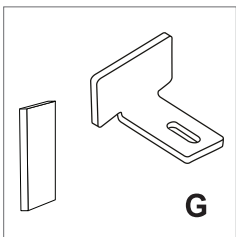
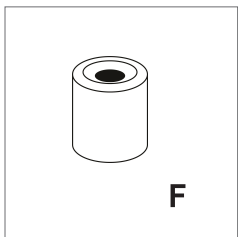
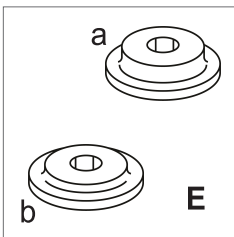
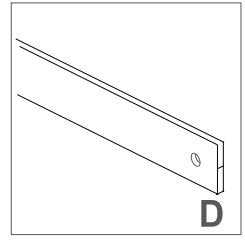
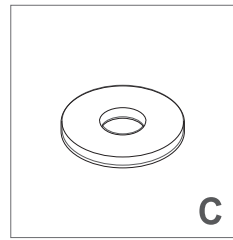
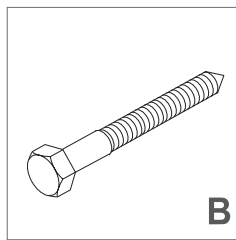
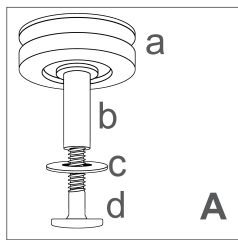

STAG HANGER Assembly Instructions

NOTE:

Doors using Floor Mount Door Guides will have a groove on the bottom. Ensure this groove is on the opposite end of the Door Hanger Installation.

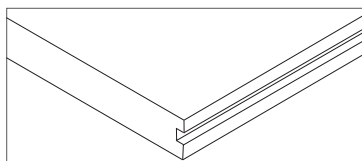

HANGER INSTALLATION

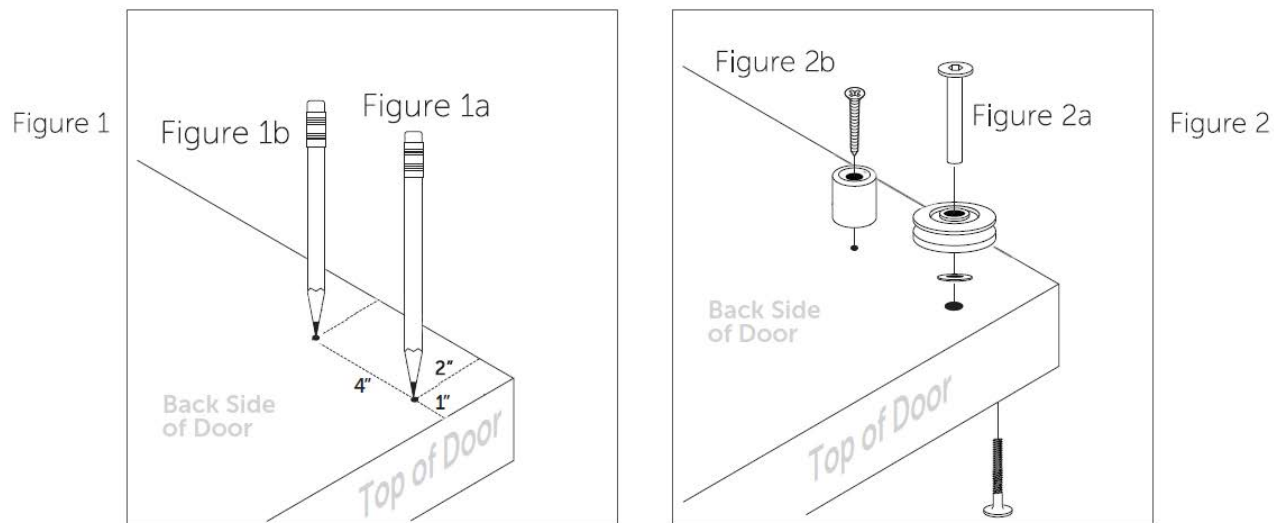

1. Lay the door with the back facing up on a flat, level surface.
2. Measure holes for the wheels 1" down from the top and 2" in from each side and mark the location. (Figure 1a). Please note that the distance "in" from the side is important when installing bi-parting doors.
3. Measure location of the anti-jump 1" from each side of the door and 4" from the top of the door (Figure 1b).
4. From the back side, drill a small pilot hole only 1/4" deep for each anti-jump using the 3/32" drill bit. Do NOT drill the pilot hole for the anti-jump all the way through the door. Drill a hole all the way through the door for the wheels at both marked spots using the 3/8" drill bit.
5. Slide the female bolt through the wheel from the narrow side of the wheel. Slide the spacer over the female bolt. Slide the female bolt (with washer and wheel) through the back side of the door. Note the female bolt may not pass all the way through. Slide the male bolt into the female bolt from the front of the door. Hand tighten with Allen wrench (Figure 2a).
6. Place the anti-jumps over the pilot hole and tighten with a Phillips screw into the pilot hole. (Figure 2b).

NOTE: If you are installing on a Rustica Metal Framed Barn Door please center the anti-jump stop on the middle of the side rail 1-3/4" from the top of the door.



Use teamwork. We recommend two people for this build.

FIRST THINGS FIRST

Check to see if the floor below the track area is level. If the floor rises more than 1/2" the door may rub or not slide well. If the floor is not level, measure from the highest point of the floor surface to the make sure the door clears the floor.

Ensure the track will be installed onto wall studs or in wall blocking. If wall studs are not lining up with the installation a header will be required to provide the necessary strength and stability for the track and door.

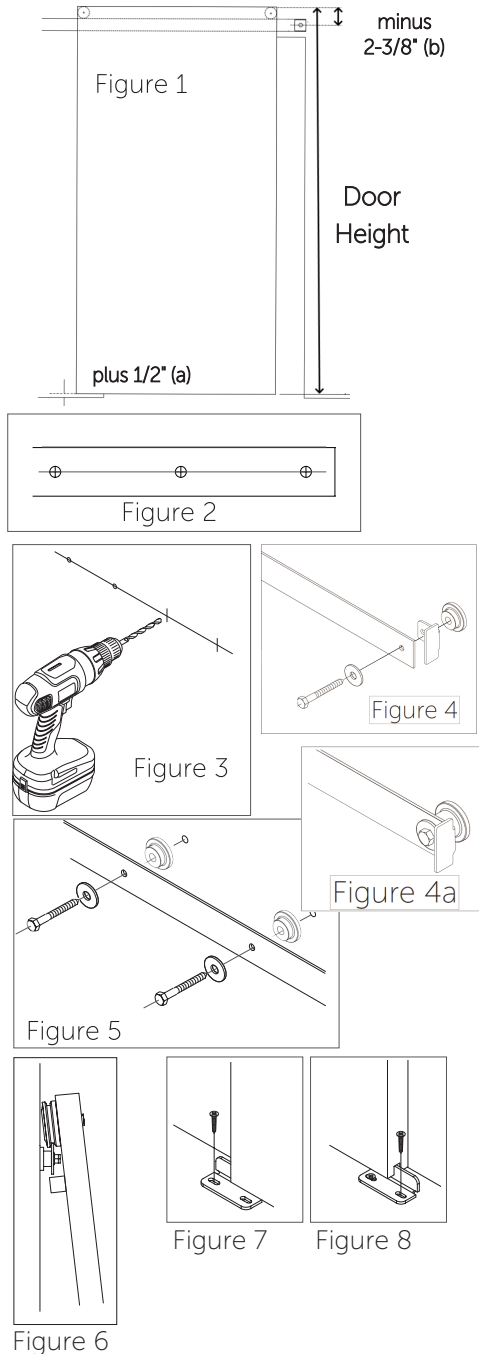

1. To determine where the track should be installed, first measure the height of the door, then subtract 1-7/8" from the door height. Plus 1/2" (a) will be for the clearance between the bottom edge of the door and the floor. Minus 2-3/8" (b) will be from the top edge of the door to the center of the track. (Figure 1).
2. Using a level and a pencil, make a line on the wall at this height. It will be the centerline of the track.
3. Hold the track up to where the pencil line is visible through the holes in the track (Figure 2).
4. Mark an intersecting line in the center of each hole (Figure 2).
5. Take the track down, drill out the marked holes using a drill with a 1/4" drill bit (Figure 3).
6. Attach one end of the track to the wall with one standard stop, one lag screw, and one washer, using a socket wrench with 9/16" socket (Figure 4). Do not tighten.
7. Repeat step 7 for the other end of the track.
8. Attach the rubber bumper to the inside of the stop. Repeat for the stop on the other end of the track (Figure 4a).
9. Install remaining spacers with lag screws and washers using a 9/16" socket wrench (Figure 5). Tighten all lag screws.
10. Hang the door by angeling the bottom away from the wall, slipping the wheel over and onto the track with the ani-jump sliding under the track (Figure 6).

DOOR GUIDE INSTALLATION

11. With the door in the closed position, ensure the door is hanging straight using a bubble level.
12. Position the Door Guide part way into the groove in the bottom of the door (Figure 7).
13. Install the Door Guide using a 1" phillips screw (provided) and a drill with a phillips bit.
14. Slide the door toward the open position until the other side of the Door Guide is exposed.
15. Install the second 1" phillips screw (provided) using a drill with a phillips bit (Figure 8).

BiParting or Double Barn Door Installation Extra Steps

1. The center of the track does not get the standard end stop even if the track is spliced. Instead an extra set of Anti-Jumps/Bi-Parting Stops are included.
2. The pair of Anti-Jumps/Bi-Parting Stops should be set on each side of the middle of the track and "stop" the wheel.
3. If installed per the instructions these stops will sit next to each other. If variations or modifications are needed simply mark where the edge of the wheel where the door needs to stop and install each Bi-Parting Stop where indicated so that it stops the door in the correct location.

