

## DS-3WF03C Outdoor Wireless Bridge

DS-3WF03C wireless bridge can be applied in industries, such as wireless video surveillance, railway, transportation, power and other industries, wireless video/data transmission, wireless coverage, carrier wireless backbone network construction, Wi-Fi wireless coverage, rural information construction, and wireless network coverage. The long-distance transmission of the device can guarantee multi-channel HD video transmission.



### Feature and Function

- Up to 15 km wireless transmission distance.
- 300 Mbps 802.11n wireless.
- Built-in 15 dBi 2x2 MIMO antenna.
- Point-to-Point, Point-to-Multipoint.
- Smooth video enhanced by TDMA technology.

### Package Content

- DS-3WF03C
- Power Adapter (24 V, 0.5 A)
- Power Cord
- Hoop
- Quick Start Guide



## Specification

Model	DS-3WF03C
<b>Wireless</b>	
Standard	IEEE802.11 a/n
Operating frequency	5745~5825 MHz (Note: Available channel may vary depending on local regulations)
Antenna	Built-in antenna: gain 15 dBi, H: 40°, V: 15°
Output power	27 dBm (Note: Maximum output power may vary in different channels depending on local regulations)
Receive sensitivity	-72 dBm@54 Mbps, -85 dBm@MCS0
Wireless Link Rate	300 Mbps
Maximum power consumption	10.1 W
<b>Hardware</b>	
Power supply	24 V/0.5 A Passive PoE
Passive PoE power supply distance	Up to 60 meters with Cat.5e or better
Interface	10/100 Mbps Base-TX × 2
Operating temperature	-30°C ~75°C (-22°F ~167°F)
Storage temperature	-40°C ~85°C (-40°F ~185°F)
Operating humidity	5%~95%RH non-condensing
Dimensions	270mm × 41mm × 88mm (10.6×1.6×3.5 in)
LED indicator	Power indicator / LAN / WLAN / signal strength indicator
Net weight	283.5g
Gross weight	708.0g
<b>Software</b>	
Encryption	WPA-PSK/WPA2-PSK
Security	IP/MAC filter, SSID hidden
Network protocol	TCP/UDP/ARP/ICMP/HTTP/NTP
Management and Logs	NTP, Syslog, SNMP
Configuration Management	Support web configuration, Support SNMP management
Firmware update	Support update firmware by Web page
Bandwidth	20 M/40 MHz



## Physical Interface



Physical Interface	Description
Reset	Restore default factory settings
LAN	Access to the camera, information distribution screen and other equipment
PoE	PoE port connection with PoE power supply

## Indicator Description



Indicator	Description
	Power indicator. If the green light is steady on, it indicates that the power is on.
LAN	Network connection light. The light indicates there is one IPC or other network device connects to the LAN port of PoE adapter. Blinking means sending data.
WLAN	Wireless indicator light. The light indicates that the wireless is enabled. Blinking means sending data.
	Signal strength indicator light. Red light on, indicating that the signal is weak or no signal. Yellow and red lights on, indicating signal level is medium. Green, yellow and red lights on, indicating the wireless signal level is strong

## Available Model

- DS-3WF03C

**Dimension (unit: mm)**

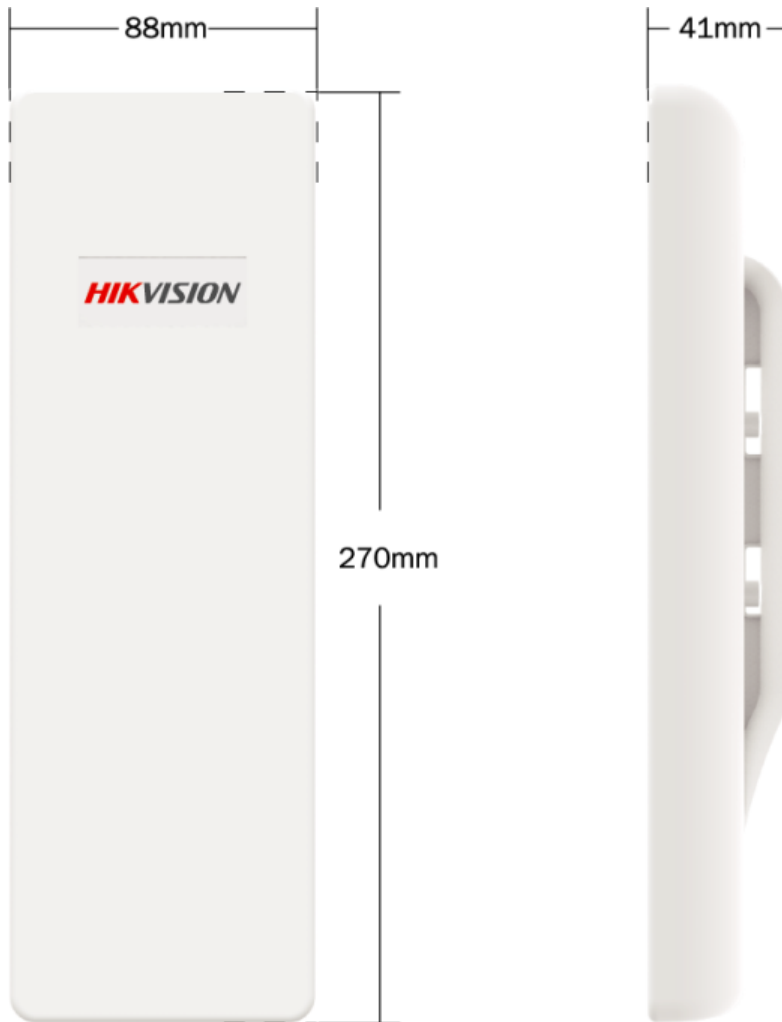

## Typical Application

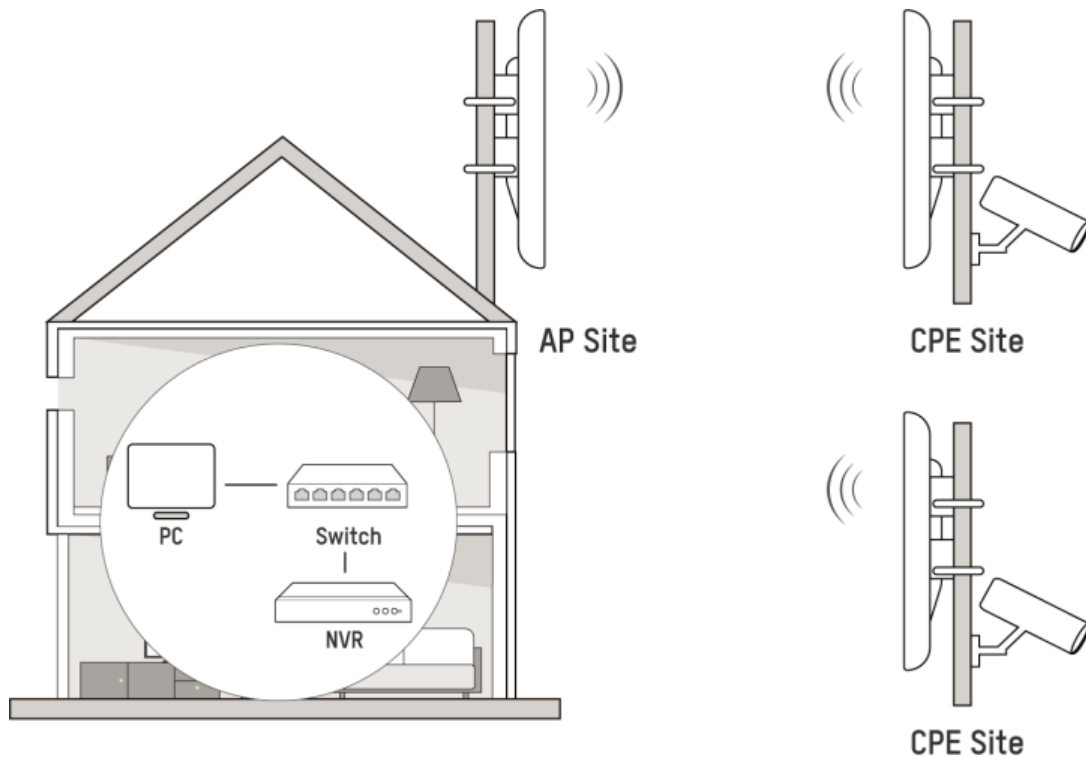

Distributed by



## HIKVISION

### Headquarters

No.555 Qianmo Road, Binjiang District,  
Hangzhou 310051, China  
T +86-571-8807-5998  
overseasbusiness@hikvision.com

**Hikvision USA**  
T +1-909-895-0400  
sales.usa@hikvision.com

**Hikvision Australia**  
T +61-2-8599-4233  
salesau@hikvision.com

**Hikvision India**  
T +91-22-28469900  
sales@pramahikvision.com

**Hikvision Canada**  
T +1-866-200-6690  
sales.canada@hikvision.com

**Hikvision Thailand**  
T +662-275-9949  
sales.thailand@hikvision.com

**Hikvision Europe**  
T +31-23-5542770  
sales.eu@hikvision.com

**Hikvision Italy**  
T +39-0438-6902  
info.it@hikvision.com

**Hikvision Brazil**  
T +55 11 3318-0050  
Latam.support@hikvision.com

**Hikvision Turkey**  
T +90 (216)521 7070- 7074  
sales.tr@hikvision.com

**Hikvision Malaysia**  
T +601-7652-2413  
sales.my@hikvision.com

**Hikvision UK & Ireland**  
T +01628-902140  
sales.uk@hikvision.com

**Hikvision South Africa**  
Tel: +27 (10) 0351172  
sale.africa@hikvision.com

**Hikvision France**  
T +33(0)1-85-330-450  
info.fr@hikvision.com

**Hikvision Kazakhstan**  
T +7-727-9730667  
nikia.panfilov@hikvision.ru

**Hikvision Vietnam**  
T +84-974270888  
sales.vt@hikvision.com

**Hikvision UAE**  
T +971-4-4432090  
salesme@hikvision.com

**Hikvision Singapore**  
T +65-6684-4718  
sg@hikvision.com

**Hikvision Spain**  
T +34-91-737-16-55  
info.es@hikvision.com

**Hikvision Tashkent**  
T +99-87-1238-9438  
uzb@hikvision.ru

**Hikvision Hong Kong**  
T +852-2151-1761  
info.hk@hikvision.com

**Hikvision Russia**  
T +7-495-669-67-99  
saleru@hikvision.com

**Hikvision Korea**  
T +82-(0)31-731-8817  
sales.korea@hikvision.com

**Hikvision Poland**  
T +48-22-460-01-50  
info.pl@hikvision.com

**Hikvision Indonesia**  
T +62-21-2933759  
Sales.Indonesia@hikvision.com

**Hikvision Colombia**  
sales.colombia@hikvision.com