

CONTENTS

1. Description of Machine	2
2. Sewlight	3
3. Installing Head into Cabinet.....	3
4. Threading the Machine & Needle	4
5. Threading the Bobbin Case	5
6. Inserting and Removing the Bobbin Case	6
7. Cleaning the Shuttle Race	7
8. Preparing for Sewing	8
9. Starting Sewing.....	8
10. Setting the Needle	9
11. Pushbutton Drop Feed (Feed Dog Position Regulator).....	9
12. Regulating the Thread Tension	10
13. Pushbutton Darner (Presser Foot Pressure Regulator)	11
14. Winding the Bobbin.....	12
15. Regulating the Stitch Length for Forward Sewing	13
16. Regulating the Stitch Length for Reverse Sewing	13
17. Regulating the Stitch Length for Zig-Zag Sewing	13
18. Regulating Width of Zig-Zag Stitch	14
19. Regulating Length of Zig-Zag Stitch.....	14
20. Inserting the Disc	15
21-22. Sewing Design.....	16, 17
23. Oiling.....	18
24. Button Sewing	19
25. Making Buttonholes.....	20
26. Darning, Embroidering & Monogramming	21
27. Narrow Hemmer	22
28. Sewing Braids.....	23
29. Felling	23
30. Cloth Guide.....	24
31. Quilting.....	24
32. Causes of Common Difficulties.....	25
33. Needle & Thread Size	26

Description of Machine

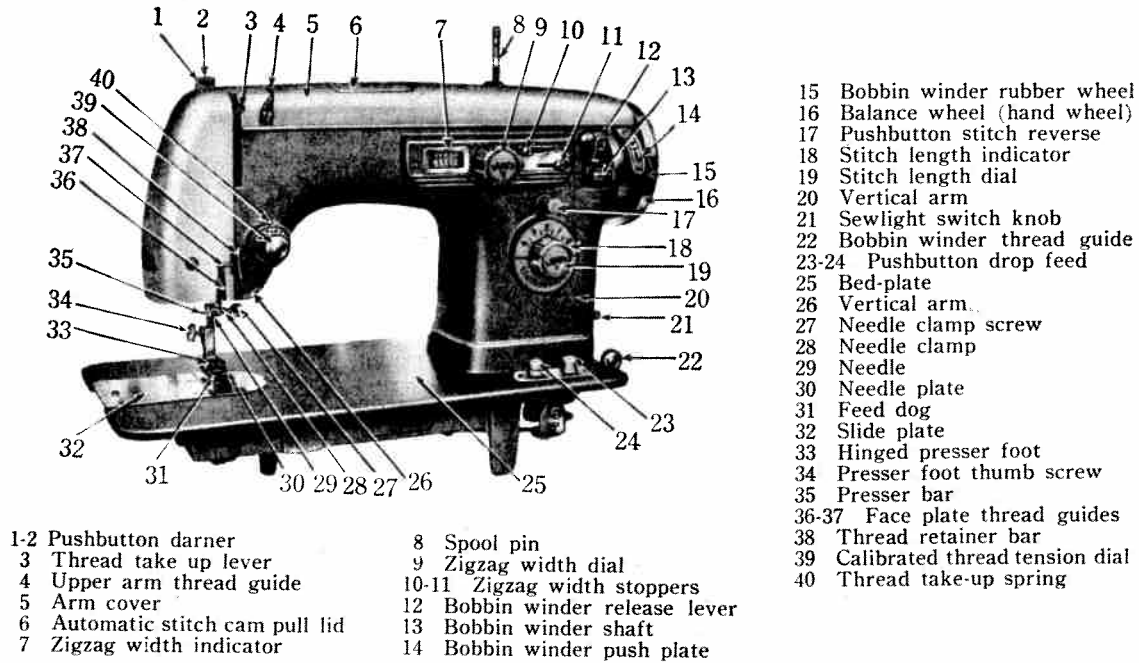

- 1-2 Pushbutton darning
- 3 Thread take up lever
- 4 Upper arm thread guide
- 5 Arm cover
- 6 Automatic stitch cam pull lid
- 7 Zigzag width indicator

- 8 Spool pin
- 9 Zigzag width dial
- 10-11 Zigzag width stoppers
- 12 Bobbin winder release lever
- 13 Bobbin winder shaft
- 14 Bobbin winder push plate

- 15 Bobbin winder rubber wheel
- 16 Balance wheel (hand wheel)
- 17 Pushbutton stitch reverse
- 18 Stitch length indicator
- 19 Stitch length dial
- 20 Vertical arm
- 21 Sewlight switch knob
- 22 Bobbin winder thread guide
- 23-24 Pushbutton drop feed
- 25 Bed-plate
- 26 Vertical arm
- 27 Needle clamp screw
- 28 Needle clamp
- 29 Needle
- 30 Needle plate
- 31 Feed dog
- 32 Slide plate
- 33 Hinged presser foot
- 34 Presser foot thumb screw
- 35 Presser bar
- 36-37 Face plate thread guides
- 38 Thread retainer bar
- 39 Calibrated thread tension dial
- 40 Thread take-up spring

Sewlight

The lamp housing is located at the front side of the arm under the arm cover (Fig. 2). The light switch knob is located at the right side of the vertical arm. To switch on the light turn the light-switch knob clockwise or counter-clockwise. To switch off the light turn the light-switch knob clockwise or counter-clockwise. In order to replace a burnt out bulb with a new one, loosen the two screws on the top of the arm-cover and remove the cover. Bulbs (15w) may be obtained at dealers, department stores and electrical stores.

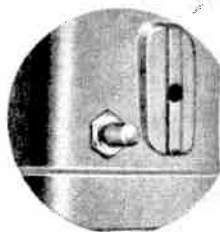

Sewlight Switch knob

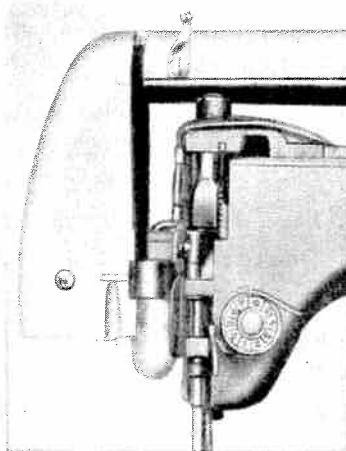

Fig. 2

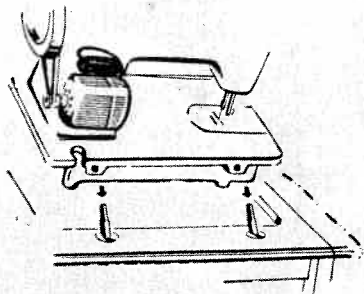

Fig. 3

Installing Head into Cabinet

1. Loosen the two hinge screws under the holes in the rear edge of the machine bed. (Fig. 3)
2. Raise hinge pins in the cabinet cutout. Slip machine head on to the pins and tighten hinge screws securely.
3. Lower machine head to front cabinet flap.

Threading the Machine & Needle

1. Turn the balance wheel toward you to raise the needle bar to its highest position.
2. Place a spool of thread on the spool pin.
3. Lead the thread through the arm thread-guide (Fig. 4).
4. Draw the thread down through the thread-guide to the tension discs from right to left and up.
5. Draw the thread up through the check spring.
6. Draw the thread under the thread retainer bar and take the thread up, and run the end through the eye of the thread take-up lever from right to left.
7. Draw the thread down through the face plate guides and then through the needle clamp thread guide.
8. Draw the end of the thread through the eye of the needle **FROM LEFT TO RIGHT**, drawing it through about 3 or 4 inches. You are now ready to sew.

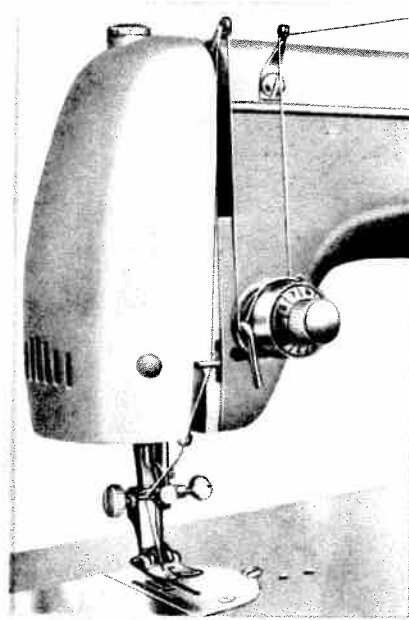

Fig. 4

Threading the Bobbin Case

Before threading the bobbin case, study Fig. 5, 6 and 7 to get a general idea as to how it is done.

1. Hold the bobbin case with your left hand and put the bobbin into the bobbin case with your right, leaving about two inches of the thread end unwound (Fig. 5). As the bobbin is being inserted in the bobbin case, the thread flow, you will note, is clockwise (Fig. 5).

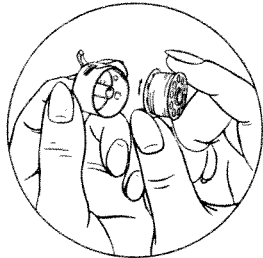

Fig. 5

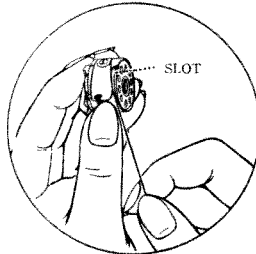

Fig. 6

2. While holding the bobbin case as before, grasp the thread end with your right hand, guide it into the cross slot (Fig. 6).
3. Then pull it through under the tension spring of the bobbin case (Fig. 6) until it enters the delivery eye (Fig. 7).

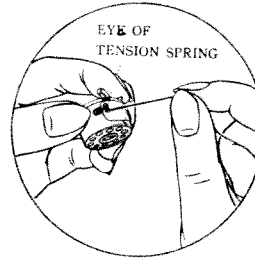

Fig. 7

2. While holding the bobbin case as before, grasp the thread end with your right hand, guide it into the cross slot (Fig. 6).

Inserting and Removing the Bobbin Case

1. Raise the presser bar by lifting the presser bar lifter.
2. Raise the needle bar to its highest position by turning the balance wheel toward you.
3. Pull out slide plate (Fig. 8).
4. After threading the bobbin case, hold its latch (Fig. 9) between the thumb and forefinger of left hand, with its position finger

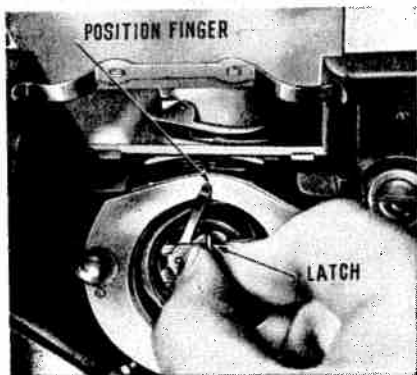

Fig. 9

opposite the notch at the top of the shuttle race and replace it on the center stud of the shuttle (Fig. 9).

5. Then release the latch and press the bobbin case back until the latch catches the groove near the end of the stud.
6. Allow the end of the thread to hang free.
7. Pull back slide plate.

To remove the bobbin case do all the above in reverse order.

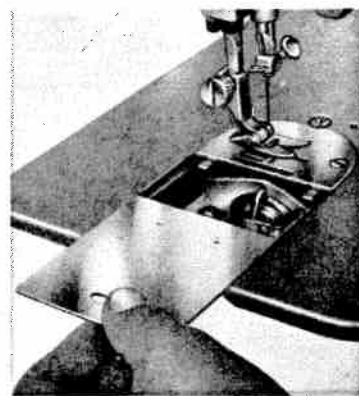

Fig. 8

Cleaning the Shuttle Race

When the thread is tangled in the race or lint gets into the space between the shuttle and shuttle-race, this will cause abrupt heavy running or complete stoppage of the machine. When this occurs:-

1. Raise the needle bar to its highest position and take the bobbin case out.

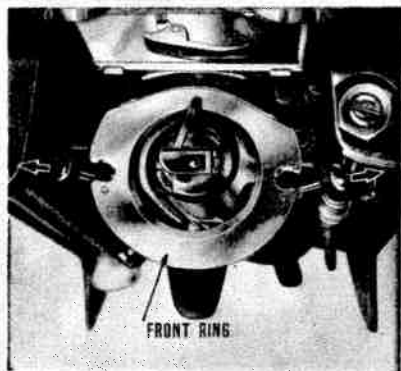

Fig. 11

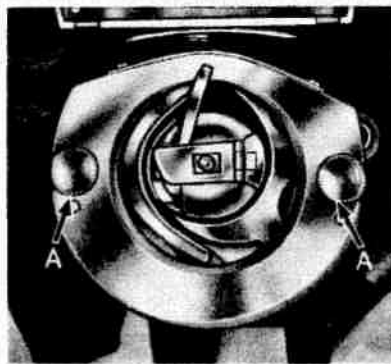

Fig. 10

2. Pull the KNOBS (A) on both side of shuttle race (Fig. 10 & 11) aside, then take out the outside ring and the shuttle body with your fingers.
3. After shuttle-race and bobbin case have been cleaned, put all of them back in reverse order

Preparing for Sewing

1. Hold the end of the upper-thread with the left hand, leaving it slack from the hand to the needle.
2. Turn the balance wheel toward you to raise the needle bar to its highest position.
3. Pull the thread you are holding, as the lower thread will be brought up with it through the hole in the needle plate, as shown (Fig. 12).
4. Place both ends of the upper and lower thread to the back of the presser foot (Fig. 13).

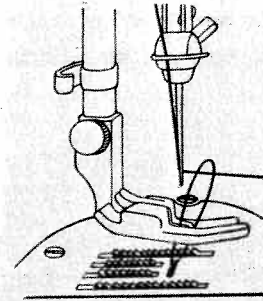

Fig. 12

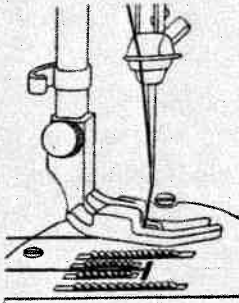

Fig. 13

Starting Sewing

1. Place the fabric to be sewn beneath the presser foot.
2. Lower the presser foot by lowering the presser bar lifter.
3. Start sewing by slowly turning the balance wheel in direction toward you while gradually working the foot or knee control.

ALWAYS TURN BALANCE WHEEL TOWARD YOU!

Setting the Needle

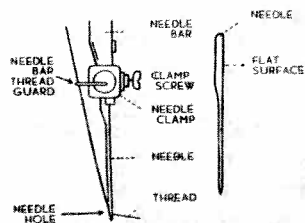

Fig. 14

1. Turn the balance wheel toward you, raising needle bar to its highest position, and loosen the needle clamp screw.
2. Hold the needle in the left hand with the point down, and insert the needle up into the needle clamp as far as it will go, with its flat surface to the right; then retighten the clamp screw (Fig. 14).

Pushbutton Drop Feed (Feed Dog Position Regulator)

The PUSHBUTTON DROP FEED is located on the bed of the machine. (Fig. 15)
It regulates the position of the feed dog for sewing very thin material and for darning and embroidering.

1. For sewing very thin material, push down the left side knob (B) until the red mark line reaches the surface of the plate.
2. For darning, embroidering and monogramming, push down the left side knob (B) completely and the feed mechanism will be lowered under the lever of the stitch plate, so that the material can be moved freely.
3. For normal sewing, push down the right knob (A) completely.

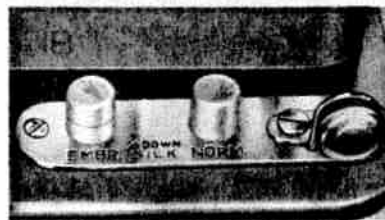
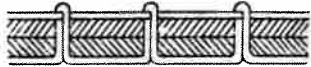

Fig. 15



Correct Stitch



Needle Thread Tension too strong

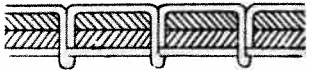

Needle Thread Tension too weak

Fig. 18

As all machines are correctly adjusted before leaving the factory and readjusted before the dealer delivers them to you, the lower tension seldom requires to be altered, but, if this becomes necessary, tighten the screw in the tension spring on the outside of the bobbin case for more tension, or loosen the screw slightly for lesser tension (Fig. 16).

Regulating the Thread Tension

For ordinary stitching the tension of the upper and lower threads should be equal so as to lock both threads in the center of the material (Fig. 18). If one tension is stronger than the other, imperfect stitching will result. Fine materials require a light tension, while heavy materials require more tension to obtain a perfect stitch.

TO INCREASE the tension, turn the thread tension dial (Fig. 17) clockwise.

TO LESSEN the tension, turn the thread tension dial in the opposite direction. (When regulating the tension always have the presser foot down).

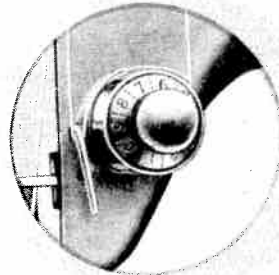

Fig. 17

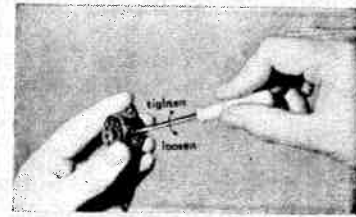

Fig. 16

Pushbutton Darnner (Presser Foot Pressure Regulator)

The PUSHBUTTON DARNER is located on top of the machine directly over the presser bar (Fig. 19 & 20). It regulates the pressure of the presser foot for sewing very heavy material, very thin material, and for darning and embroidering.

1. To eliminate the pressure of the presser foot for darning, embroidering and monogramming, push down the OUTSIDE RING of the PUSHBUTTON DARNER (A) and the material can be moved by hand while the machine is running at a fair speed. (Fig. 19)
2. To increase the pressure of the presser foot for sewing very heavy material, normal material and very thin material, push the PUSHBUTTON DARNER (B) gradually down to increase the pressure of the presser foot accordingly. (Fig. 20)



Fig. 19

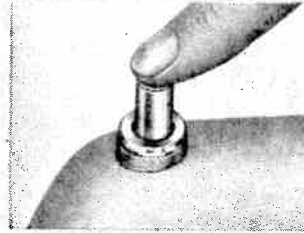

Fig. 20

Winding the Bobbin

1. To wind the bobbin, the balance wheel must be disconnected from the stitching mechanism. Hold the balance wheel with your left hand and turn the stop motion knob (Fig. 22) toward you with your right hand. This will permit the balance wheel to turn freely while the needle bar remains motionless. The balance wheel is now disconnected for the bobbin winding operation.
2. Place a spool of thread on the spool pin. Draw thread from the spool over arm guide down ward across machine from left to right. (Fig. 21)
3. Pass the thread through the tension disc of the bobbin winder thread guide located at the right corner of the machine bed.
4. Now wind the end of the thread around an empty bobbin seven or eight times and place the threaded bobbin on the spindle of the bobbin winder.
5. By pressing on the bobbin winder lever, the small rubber wheel is brought in contact with the balance wheel. To lock into position, press bobbin winder lever until a click is heard. The bobbin winder stop latch is now touching the shaft of the bobbin. It holds the bobbin in place.
6. Now manipulate your foot control or knee control in the same manner as in sewing and when the bobbin is completely full it will release automatically and stop turning. Detach bobbin from spindle. Hold balance wheel firmly with left hand and with the right hand turn stop motion knob away from you until it can not be moved any further and the needle bar moves with the turning of the balance wheel.

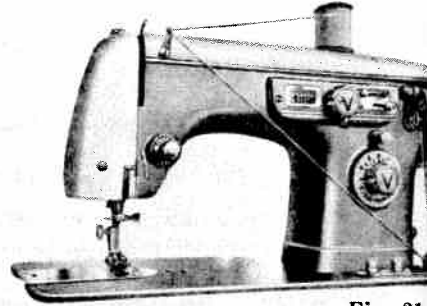

Fig. 21

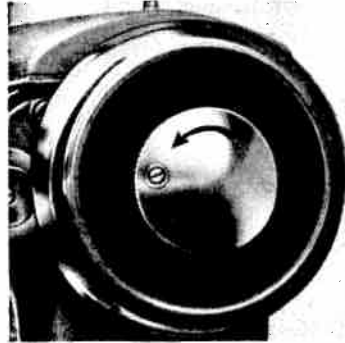

Fig. 22

Regulating the Stitch Length for Forward Sewing

The length of the stitch can be changed with the stitch length dial (Fig. 23). In order to set a certain length of stitch, turn the dial from 0~4 until the selected number on the scale is facing the alignment mark on the stitch length dial. The length of the stitch is increasing from 0~4. The normal stitch is 2.

Regulating the Stitch Length for Reverse Sewing

- a. Regulate the length of the stitch as for forward sewing (see above).
- b. Push reverse stitch button located above the stitch length (Fig. 23) as far as it will go. The machine will then sew in reverse with the same stitch length as previously selected. During reverse sewing, push the reverse stitch button all the time. After release the machine resumes forward sewing with the same stitch length.

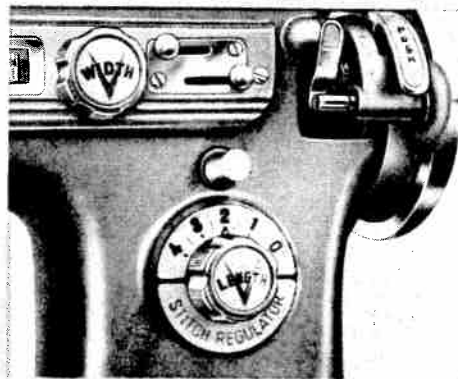

Fig. 23

Regulating the Stitch Length for Zig-Zag Sewing

The stitch length dial regulates the length of the zigzag stitch for zigzag sewing in the same manner as for straight sewing. In order to produce the "Satin Stitch" which is the closest zigzag stitch, set the stitch length dial close to 0.

Regulating Width of Zig-Zag Stitch

The width of the zigzag stitch is regulated by the zigzag width dial (Fig. 24). By turning the zigzag width dial, the zig-zag width indicator appearing in the zigzag width window, will move from 0~4 and the width of the zigzag stitch will increase accordingly. In order to revert to the previously used zigzag width, for example, for sewing on buttons, making buttonholes, tacking, etc., use the two stoppers located above the zigzag width window. Untighten the stoppers by turning the lock screw to the left. The stoppers can be moved freely and set at the desired stitch width number. Tighten the stoppers and fix them at the desired stitch width number by turning the lock screw to the right.

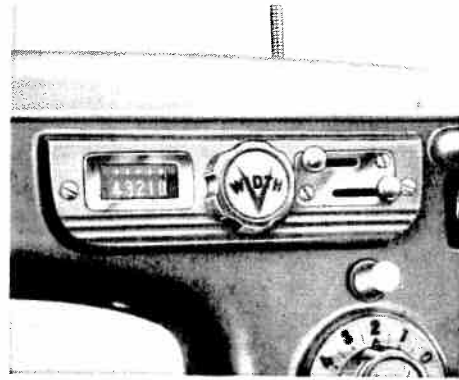

Fig. 24

Regulating Length of Zig-Zag Stitch

The stitch length dial regulates the length of the zigzag stitch for zigzag sewing in the same manner as for straight sewing (See page 13). To produce the "Satin Stitch" which is the closest zigzag stitch, set the stitch length dial close to 0 and adjust the pushbutton drop feed (feed dog position regulator) according to the material you are sewing. (See page 9)

Inserting the Disc

To insert a zig zag disc into the machine follow these instructions:

1. Pull lid (A) open.
2. Push zig zag width dial (B) to the extreme right, and keep it there during insertion.
3. Insert disc onto axle (C). Turn disc until it slips down and the retaining pin (D) enters hole (E) in disc.
4. Release dial (B).
5. Close lid (A).

To remove the disc, open the lid, push dial (B) to the right and pull disc up.

Now you can insert another disc to produce another design.

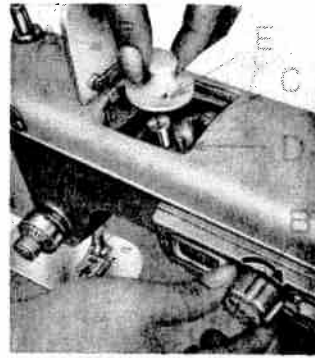
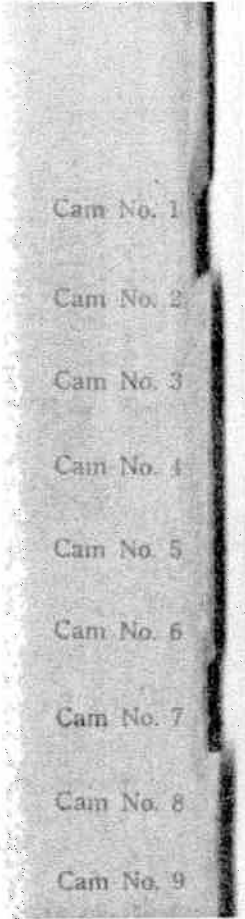
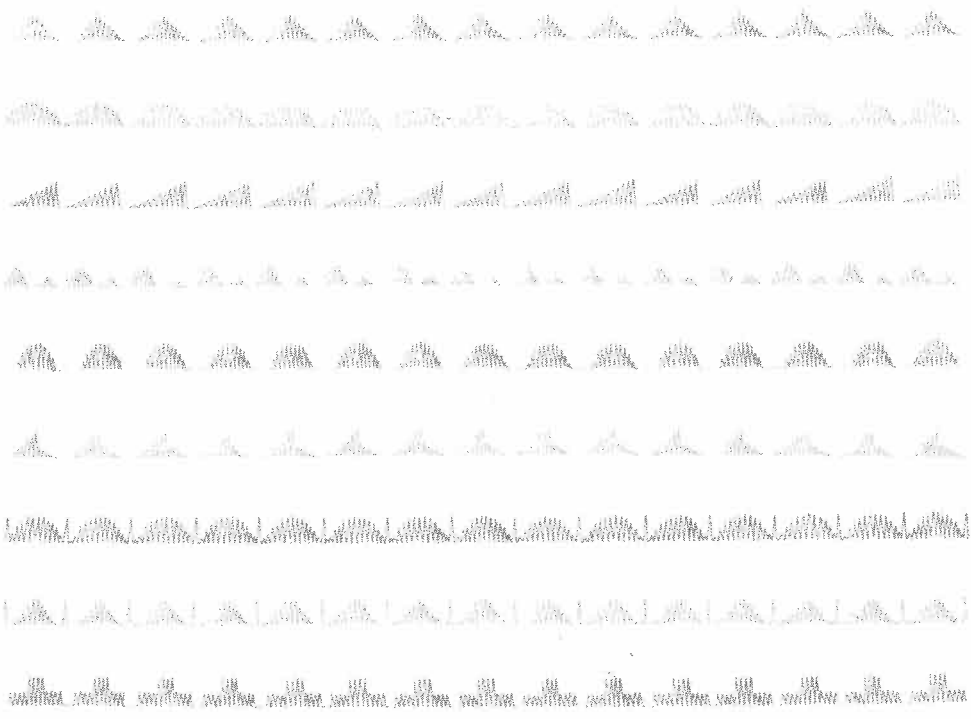

Fig. 25

Cams attached to the machine)



SEWING DESIGNS



Cam No. 1

Cam No. 2

Cam No. 3

Cam No. 4

Cam No. 5

Cam No. 6

Cam No. 7

Cam No. 8

Cam No. 9

SEWING DESIGNS

m No. 10



m No. 11

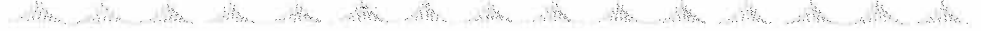

m No. 12



m No. 13

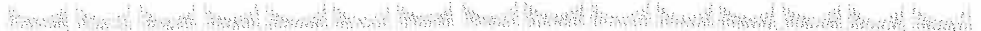

m No. 14



m No. 15



m No. 16



m No. 17



m No. 18



Oiling

To see that your machine is always in smooth running condition you must keep it oiled at all times. No grease is required. Just a drop of oil is sufficient at each time of oiling. Points to be oiled are illustrated in Fig. 28A & 28B. To oil your machine thoroughly, it will be necessary for you to open arm cover and to turn the machine over to get to parts underneath the bed.

After oiling, run the machine at high speed for a few minutes to let the oil penetrate to all parts.

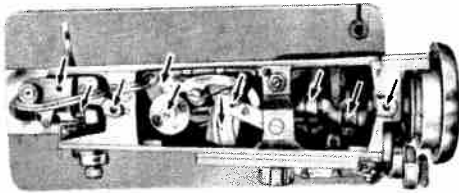

Fig. 28A

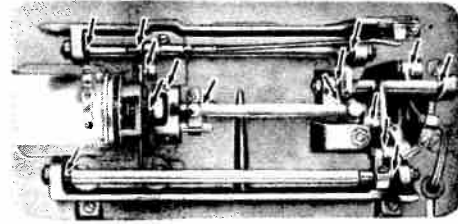

Fig. 28B

Button Sewing

Turn balance wheel toward you to get needle to its highest position. Raise presser bar and remove regular presser foot, attach button sewing foot instead, as shown in Fig. 29. Drop the feed dog as required for darning and embroidering. Upper and lower thread tensions remain the same as for ordinary sewing. Place material or garment with button under the presser foot, so that holes in button line up with oblong hole in presser foot. Adjust width of zigzag stitch to permit needle to pass through center of holes in button.

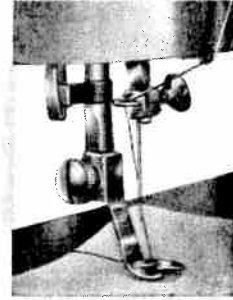

Fig. 29

Before sewing with power, turn balance wheel by hand (toward you) making one stitch into each hole in the button and be sure that needle will not hit same. Then sew five to six stitches to attach button.

When attaching four-hole buttons, first sew one set of two holes, then stitch into second set of two holes and lock thread with two or three plain stitches in last hole same as described above.

Making Buttonholes

1. Set zig-zag width between marking 1 and 2. Loosen lock screw and set the stoppers, then tighten lock screw securely.
2. Raise presser foot and turn balance wheel toward you to bring needle to its highest position. Remove regular presser foot from presser bar by loosening thumb screw. Instead attach special buttonhole foot shown on Fig. 30. Tighten thumb screw.
3. Set stitch length to obtain closely spaced forward stitches. Best length of stitch for buttonhole is when indicator is placed between markings 0 and 1 on dial. Adjust length of stitch, if necessary, to get best possible appearance of buttonhole.
4. Slightly tighten needle thread tension, turning thread tension to the right. If appearance of buttonhole should not prove satisfactory, slightly vary tension until the desired results are obtained.

NOTE: It is suggested that you make one or two sample buttonholes on a clipping of fabric, same as your garment, to test adjustments of machine and to make corrections, if needed. Also mark with pencil or chalk the position and exact length of buttonhole on garment.

To sew buttonhole, place garment under the buttonhole presser foot and start the work with one end of the mark

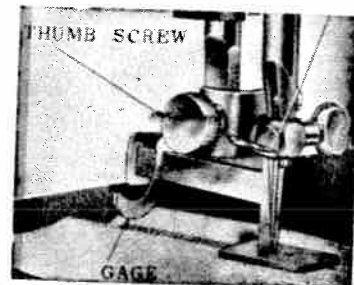

Fig. 30

in center of half-moon shaped stitch hole of the presser foot. End of marking must point toward you. Now start sewing left buttonhole seam and continue sewing until it reaches the gauge of the buttonhole foot. (This gauge must be set in advance of sewing. Its distance from the needle should be equal to the desired length of your buttonhole). Leave needle in fabric, raise presser foot and sewing garment half-way around in clockwise direction. Let presser foot down and set zigzag width as far as it can be moved. Sew four or five stitches which constitute the bar at one end of the buttonhole. Return zig-zag width to the position between markings 1 and 2 and sew other side of buttonhole. When arriving at end of buttonhole, again set zig-zag width for sewing second bar with also four to five stitches.

Remove garment from machine and open buttonhole with buttonhole cutter included in accessories, or use buttonhole scissors. Work cutting blades only against wooden block and be careful to avoid cutting the buttonhole stitching. To make reinforced buttonholes introduce gimp of proper size into small hole right in front of the half-moon shaped stitch hole of the buttonhole presser foot.

Sew over gimp as machine makes buttonhole seams. For flat buttonholes leave thread tension pretty much the same as for ordinary sewing.

Darning, Embroidering & Monogramming

Push down left pushbutton of your pushbutton drop feed, then the feed dog of the machine will drop and permit the work to be moved by hand in any direction desired. Also remove presser foot and raise foot lifting lever into horizontal line, and your machine is ready for embroidering and darning. Embroidery will be done most successfully when material is stretched in an embroidery hoop. Hold the hoop closely on the machine base with both hands and press the material with your left index finger in the vicinity of the needle. This will help in holding down the material and will prevent the machine from making skip stitches. Manipulate work carefully and be sure to keep finger out of path of needle to avoid injury. Adjust thread tensions for best appearance of embroidery work and slightly increase the lower thread tension (bobbin thread) to avoid the lower thread from being pulled up.

Narrow Hemmer

Turn balance wheel toward you until needle reaches its highest point. Raise presser bar and remove regular presser foot.

Attach hemmer foot (Fig. 31). Now handle material as follows:

1. Fold over edge of material approximately $\frac{1}{8}$ " wide, then fold it over again in the same way for a length of about 2". Insert this folded end from beneath into spiral formed opening (scroll) of hemmer foot. Move material back and forth until the hem forms itself in the scroll.
2. Pull material toward you until the beginning of the hem is just below the needle.
3. Lower presser foot and begin to sew. Guide material into hemmer foot while proceeding with work (Fig. 31).

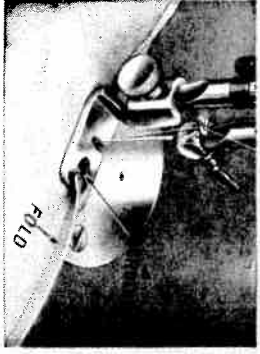

Fig. 31

NOTE: Do not crowd material into scroll and do not leave scroll only partly filled by material. Feed just enough material into the hemmer foot to fill out the scroll.

Instead of a straight stitch, you can also use a zig-zag stitch for this hemming operation. Be sure however, to adjust the width of the zig-zag stitch to be as wide as the hem itself. Using a very long stitch and tight tensions will produce a shell stitch.

Sewing Braids

Remove ordinary presser foot from the machine and attach braiding foot, as shown in Fig. 32. Introduce braid through small hole at front of foot. Adjust width of zig-zag stitch and length of stitch to obtain a covering of the braid which appears most desirable for the material you are sewing. Using needle thread of a contrasting color will enhance the beauty of your braiding.

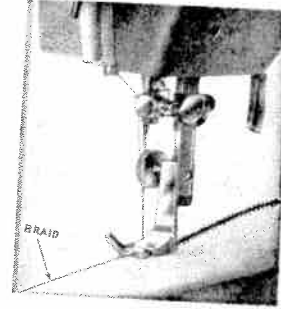

Fig. 32

Felling

Use the hemmer foot for doing felling and proceed in the following manner:

1. Lay two pieces of cloth one on top of the other with their RIGHT sides facing each other. The right edge of the bottom piece must extend about $\frac{1}{8}$ inch beyond the right edge of the top piece. See Fig. 33.
2. Sew both pieces of cloth together using the hemmer foot like a regular presser foot. Use the right edge of long toe of hemmer foot to guide the bottom piece of material, while the left edge of the same toe serves as a guide for the top piece of material. Fig. 33 shows this detail.

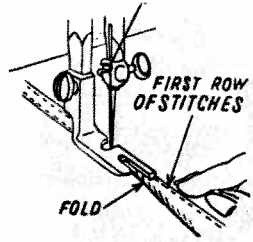

Fig. 34

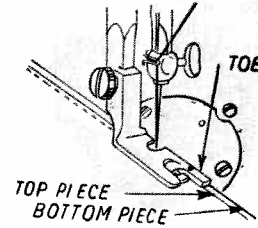

Fig. 33

3. Open and spread out material and put back on machine right sides downward. Make sewn edges of material stand up.
4. Fold over the edges to the left and insert them into the scroll of the hemmer foot. Sew as you would do ordinary hemming. Use left edge of long toe of hemmer foot as guide, having original seam run alongside of it (Fig. 34).

Cloth Guide

The cloth guide (Fig. 35) serves as a guide for straight stitching when making wide hems, deep tucks or seam widths which are greater than presser foot allows. It is attached to machine as illustrated.

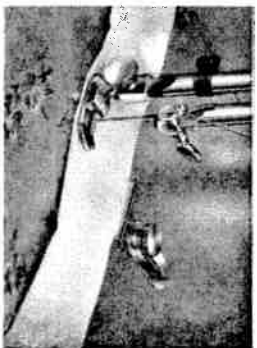

Fig. 35

Quilting

The quilter (Fig. 36) will enable you to sew equi-distant lines on padded fabrics without the necessity of marking them in advance.

To attach the quilter to the presser bar of the machine, first pull long wire hook out of horse-shoe shaped clamp. Slide the clamp on the presser bar from behind and above ordinary presser foot, and push the wire hook into its previous place.

Adjust wire hook to desired distance from needle and bring it to press into fabric. Then tighten thumb screw extending backward from horse-shoe shaped clamp to lock quilter attachment into place. When sewing, wire hook should follow preceding line of stitching.

Zig-zag stitch quilting is done the same as straight stitch quilting with the exception of the position of the zig-zag stitch dial which should be set for any desired width of zig-zag stitch.

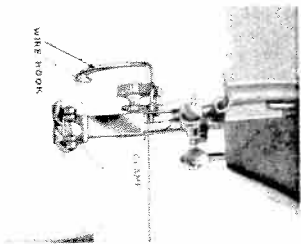

Fig. 36

Causes of Common Difficulties

BREAKING OF THE UPPER THREAD:

- | | |
|--|--|
| 1. Incorrect threading | 2. Upper thread tension too tight |
| 3. Faulty needle, or needle set incorrectly | 4. Needle brushing against presser foot or other attachments |
| 5. Needle eye too small for thread used | 6. Starting the machine suddenly or with a jerk |
| 7. Starting the machine with the take up lever at its highest position | |

BREAKING OF THE LOWER THREAD:

- | | |
|---|--|
| 1. Incorrect threading of the bobbin case | 2. Lower thread tension too tight |
| 3. Bobbin being wound too fully | 4. Rough edge of hole in needle plate caused by improper needle action |

BREAKING OF THE NEEDLE:

1. Pulling the fabric while machine is running, thus causing the needle to strike the needle plate
2. Using bent needle

SKIPPING STITCHES:

- | | |
|---|--------------------------------|
| 1. Using bent or blunt needles | 2. Needle inserted incorrectly |
| 3. Needle threaded improperly | 4. Using wrong sized needle |
| 5. Pressure of presser foot insufficient, especially when sewing heavy material | |

UNEVEN STITCHES:

- | | |
|---|---|
| 1. Presser foot not resting evenly on material | 2. Feed dog not being high enough |
| 3. Too short stitches used | 4. Pulling the cloth while the machine is running |
| 5. Using a too fine a needle with a too coarse thread | |

NEEDLE AND THREAD SIZES (USE 15×1 NEEDLE ONLY)

Sizes & Grades of Needles	Type of Fabric and Work to be Done	SIZE OF THREAD		
		Cotton	Silk	Linen
B or 11 (Medium-Fine)	Medium light-weight and summertime fabrics. For house dresses, children's dresses, washable cotton dresses, aprons, curtains.	80 to 100	0 Twist	
½ or 14 (Medium)	Dress silks and cottons, light weight woolens, draperies, fabric furnishings. For general household sewing, fine men's shirts, smocks, window draperies and fabric decorations.	60 to 80	A & B Twist	
1 or 16 (Light-Heavy)	Heavy cretonne, madras, muslin, brocades and quilts. For men's work shirts, sturdy smocks and aprons, heavy quilting and fabric furnishings.	40 to 60	C Twist	
2 or 18 (Medium-Heavy)	Heavy woven coating, light weight canvas, bed ticking, upholstery and awning materials, slipcover fabrics. For work or sports uniforms, suits made of strong linen or cotton fabrics, awnings, slip covers and mattresses.	30 to 40	D Twist	
3 or 19 (Heavy)	Heavy woven suiting, coating, duck, ticking, drilling, canvas and sacking. For heavy wash uniforms, bedding supplies for hospitals, hotels and camps.	10 to 30	E Twist	60 to 80
4 or 21 (Extra-Heavy)	For bags, canvas, coarse cloths and heavy goods.	Very Coarse		40 to 60

Printed in Japan