

INSTRUCTIONS
FOR USING

SINGER

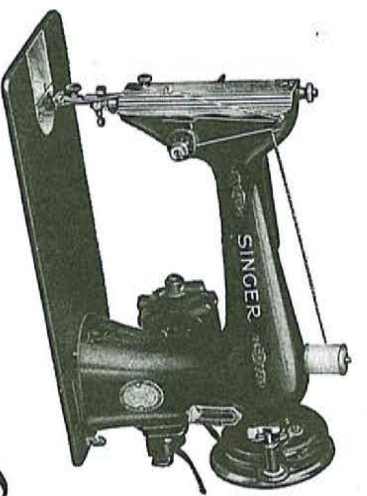

SEWING MACHINE

66-16

The SINGER 66-16 is another in a long line of products resulting from the skill and ability of SINGER craftsmen.

Form 20238
(Rev. 7-76)

*A Trademark of THE SINGER COMPANY
Copyright © 1954 by The Singer Co.
All Rights Reserved Throughout the World

Printed in U.S.A.

AS THE OWNER OF THIS
SINGER SEWING MACHINE:

You have a machine made with the same care and craftsmanship that have been the hallmark of SINGER products for more than a century. We are acutely aware that SINGER Sewing Machines have become an American tradition and are intensely proud of, and determined to continue, this heritage.

Your SINGER "66" is the product of this pride, determination and the unsurpassed technical skill of SINGER. This smooth-running machine, combined with your own skill, will bring you a new world of sewing enjoyment. Exclusive dresses for yourself, clothing for your family and a multitude of items for your home will be yours—all at a fraction of their ready-made cost.

WHAT SINGER SERVICE MEANS TO YOU

Over 1400 SINGER SEWING CENTERS in the United States alone serve women who sew. INSTRUCTION by skilled teachers is given to purchasers of new SINGER SEWING MACHINES at no extra charge. Budget courses in home dressmaking, home decoration and Fashion Stitching are also available.

REPAIR SERVICE is as convenient as your telephone. Whenever your machine needs adjustment, a trained SINGER representative will call at your home. SINGER* Service assures excellent workmanship, guaranteed repairs and SINGER* parts. A written estimate is given for your approval.

And remember, your SINGER SEWING CENTER and the SINGER Service car are identified by the famous SINGER Red "S"

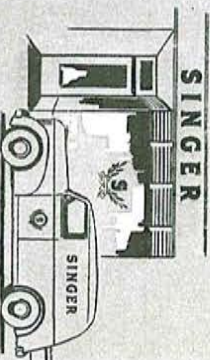
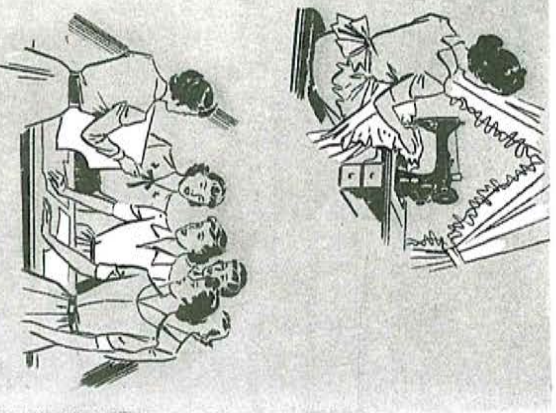

ELECTRICAL INFORMATION

The SINGER* Electric Motor is located at the back of the machine and can be operated on either alternating or direct current. The standard windings of the motor are for 110-120 volts, and motors can be furnished for any voltage between 95 and 250. Special motors can be furnished for 32 volts direct current, and for 50 volts alternating or direct current.

Before Inserting Electric Plug
Be sure voltage and number of cycles stamped on motor nameplate are within the range marked on the electric meter installed by the electric power company.

To Connect the Machine to Electric Service Line
Push three-pin terminal plug on three-pin terminal block at right of machine and connect plug at other end of cord to nearest electric outlet.

4

THE LIGHT

The light is turned "on" or "off" by turning switch A, Fig. 2 to the right.

To Remove the Bulb

Grasp light socket so that thumb extends over switch A. Press shade with thumb at B to release it from two catches and slide it halfway out of shade holder D. Do not attempt to unscrew bulb. Press it into socket and at same time turn bulb over from the machine in direction shown in Fig. 2B to unlock bulb pin C, Fig. 2, then withdraw bulb.



Fig. 2A

5

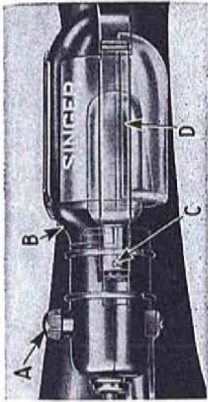

Fig. 2. The Light

To Replace the Bulb

Press new bulb into socket with bulb pin C, Fig. 2 entering slot of socket and turn it over toward the machine in direction shown in Fig. 2B to lock bulb pin in position. Return shade to position shown in Fig. 2.

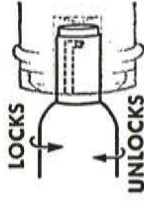

Fig. 2B

CHART SHOWING RELATIONSHIP OF TYPES OF FABRICS, THREAD AND NEEDLE SIZES AND MACHINE STITCH SETTINGS

TYPES OF FABRICS	THREAD SIZES	NEEDLE SIZES	MACHINE STITCH SETTINGS	
			Inside Seams	Top Stitching
Filmy materials comparable to net, marquisette, organdy, nigan.	100 Cotton 60 and 000 Silk	9	20	30
Sheer materials comparable to lawn, dimity, voile, bobble, chiffon, rayon sheer, rayon crepe.	80 to 100 Cotton 0 Silk	11	16	20
Lighthweight materials comparable to gingham, chambray, sheer wool crepe, toffeto.	50 Mercerized 60 to 80 Cotton A and B Silk	14	12	18
Medium lightweight materials comparable to poplin, pique, percale, cretonne, chintr, faille, bengaline, wool flannel, wool crepe, wool jersey.	50 Mercerized 50 to 70 Cotton B Silk	14	12	16
Medium heavy materials comparable to crash, gabardine, rep, corduroy, velveteen.	Heavy Duty Mercerized 40 to 50 Cotton C Silk	16	10	12
Heavy materials comparable to sailcloth, denim, ticking.	30 to 40 Cotton 24 to 30 Cotton D Silk	18 19 18 or 19	8	10
Very heavy materials comparable to overcoating.	40 to 60 Linen 20 to 24 Cotton E Silk	21	6	8
Plastic materials.	Mercerized Cotton	11	10	12

When ordering needles, always specify "Class and Variety 15 x 1" and state the size and quantity required. You will obtain the best stitching results from your Sewing Machine if it is fitted with a SINGER* Needle.

6

TO REMOVE THE BOBBIN

Raise needle to its highest point. Draw the slide in bed of machine to the left and press down on bobbin ejector J, Fig. 3. This will raise bobbin so that it can be easily removed from bobbin case.

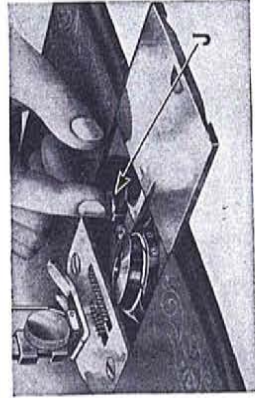

Fig. 3. Removing the Bobbin

TO WIND THE BOBBIN

To stop motion of needle, hold hand wheel K, Fig. 4 and loosen knurled screw L by turning it toward you.

Place bobbin on bobbin winder spindle, as shown in Fig. 5, as far it will go.

Press bobbin winder against hand wheel until latch N, Fig. 5 drops down and holds bobbin winder pulley P against the hub of the hand wheel.

Place spool of thread on spool pin.

Lead thread through guide 1 on arm of machine, and into the lower notch of bobbin winder thread guide 2 at the front of machine bed.

7

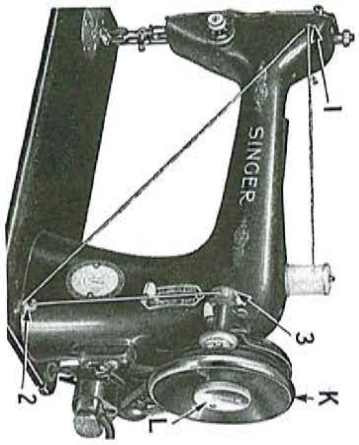

Fig. 4. Machine Threaded for Winding the Bobbin

Pass thread back of guide 2 and into its upper notch, and through hole M, Fig. 5, in left side of bobbin 3 from the inside.

Hold end of thread and press controller as for sewing. The end of the thread must be held until it breaks off. Fig. 5 shows bobbin winder in position for winding.

Allow guide 2 to control flow of thread so that it winds on bobbin in uniform level rows.

When bobbin is filled, the bobbin winder is automatically released.

8

TO REPLACE THE BOBBIN

Hold bobbin between thumb and forefinger of left hand, the thread leading on top from right to left, as shown in Fig. 6.

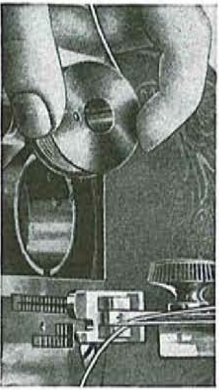

Fig. 6. Replacing the Bobbin

10

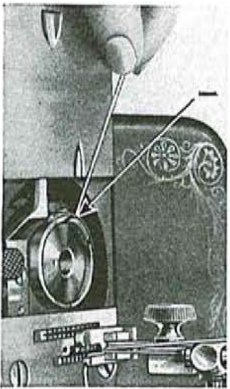

Fig. 7. Threading the Bobbin Case

Place bobbin into bobbin case and draw thread into slot 1, Fig. 7 in bobbin case, as shown. Draw thread backward between bobbin case and tension spring until it reaches notch 2, Fig. 8, then pull thread toward the right, as shown

Remove bobbin from spindle and retighten knurled screw L, Fig. 4. If thread does not wind evenly on bobbin, loosen the screw which holds bobbin winder thread guide 2, Fig. 4 on bed of machine. Turn this guide to the left if bobbin winds high on the right. Turn guide to right if bobbin winds high on the left. When guide is properly centered, thread will wind evenly across bobbin. Then tighten thread guide screw. If pressure of bobbin winder pulley P, Fig. 5 against hub of hand wheel is insufficient for winding bobbin, press down on bobbin winder until latch N drops and loosen adjusting screw Q. Then press pulley P firmly against hand wheel and press down latch N while tightening screw Q.

9

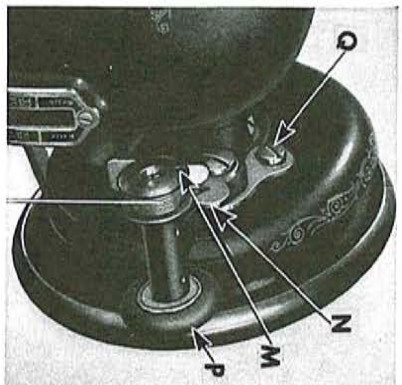

Fig. 5. Bobbin Winder Adjustment

in Fig. 8. When closing the slide, see that the thread is in slot 3, Fig. 9 in right edge of slide, as shown.

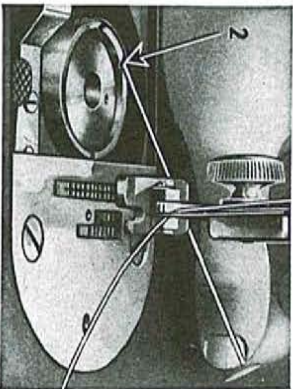

Fig. 8. Bobbin Case Threaded

11

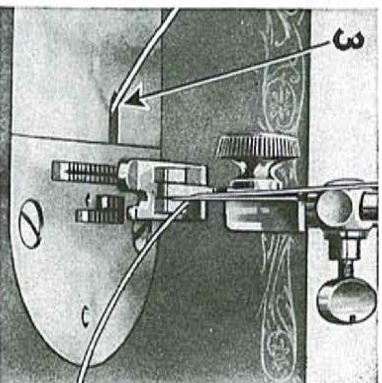

Fig. 9. Under Threading Completed

NEEDLES AND THREAD

For perfect stitching, thread should be selected according to fabric to be stitched. Needle must be correct size for thread which must pass freely through eye of needle.

Select correct needle according to chart on page 6.

Be sure that needle is not blunt or bent.

TO SET THE NEEDLE

Raise needle bar to its highest position and loosen thumb screw H, in needle clamp.

12

Insert needle with its flat side to the right up into needle clamp as far as it will go, then tighten thumb screw H.

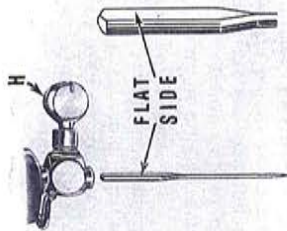

Fig. 10. To Set the Needle

13

UPPER THREADING

See Fig. 11

1. Raise take-up lever 5 to its highest point.
2. Place spool of thread on spool pin
3. Lead thread into thread guide 1
4. Down and from right to left between tension discs 2
5. Into the loop of take-up spring 3
6. Under slack thread regulator 4 (not through eye in thread regulator)
7. Up and from right to left through hole in take-up lever 5
8. Down through guide 6 on face plate
9. Down through lower wire guide 7
10. From left to right through eye of needle 8.
11. Draw about two inches of thread through eye of needle.

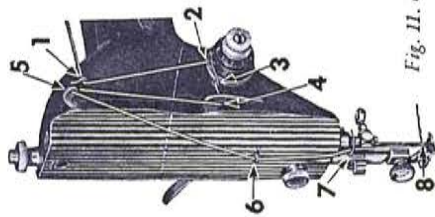

Fig. 11. Upper Threading

TO PREPARE FOR SEWING

Hold end of needle thread with left hand and turn hand wheel over toward you until needle moves down and up

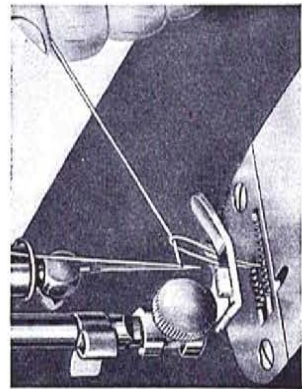

Fig. 12. Drawing Up the Under Thread

14

TO START SEWING

Be sure to have thread take-up lever 5, Fig. 11 at its highest point.

Place material beneath presser foot R, turn hand wheel to bring point of needle into material, then lower presser foot by means of presser bar lifter S, and start to sew. Press controller to start machine. The speed depends upon amount of pressure on controller.

Most materials require only guiding for best sewing results. However, the miracle fabrics such as nylons, dacrons, orlons, blends with various rayons, puffed weaves, sheers, jerseys and tricots, which, by their nature, require light pressure, also require support in the form of holding the material taut at

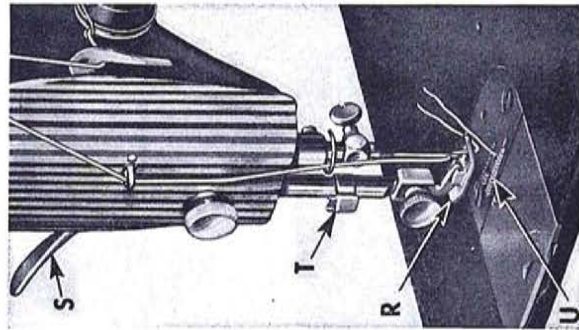

Fig. 13. To Start Sewing

15

the back and front of the needle as the needle enters the fabric. This support assures a smooth, even seam.

Never pull the material when sewing.

The machine will sew its own thread when sewing from one piece of material to another. However, avoid operating a threaded machine with presser foot up and without fabric under the foot.

TO TURN A CORNER

Stop machine when eye of needle reaches material on its upward stroke. Raise presser foot and, using needle as a pivot, turn material as desired. Then lower presser foot and resume sewing.

BASTING

The longest stitch, No. 6 on the stitch indicator, is satisfactory for basting. The basting stitches are easily removed by clipping every sixth stitch and withdrawing the long continuous thread.

Machine basting is firmer, more even and much quicker than hand basting.

TO SEW BIAS SEAMS

Use a shorter stitch when sewing bias or curved seams to increase the elasticity of the seam and to prevent seam failure under pressure. No change in tensions is required.

TO REMOVE THE WORK

Stop machine with thread take-up lever 5, Fig. 11 at its highest point.

Raise presser foot by means of presser bar lifter S, Fig. 13, draw fabric back and to the left and sever threads on thread cutter T, Fig. 13. Place ends of threads under presser foot. When machine is not in use, raise presser foot to prevent injury to presser foot and feed U, Fig. 13.

TO REGULATE LENGTH OF STITCH

The machine is adjustable to make from 6 to 25 or more stitches per inch, as indicated by the numerals on stitch indicator plate V, Fig. 14.

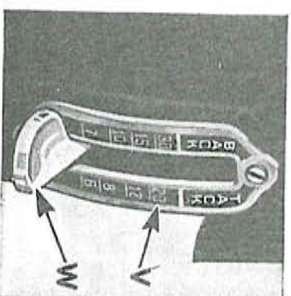

Fig. 14. To Regulate Stitch Length

To change length of stitch, set lever W, Fig. 14 with its upper side in line with the numeral representing the desired number of stitches per inch.

TO REVERSE THE DIRECTION OF FEED

To feed the material toward you, raise the lever W, Fig. 14 to the upper portion of the stitch indicator plate V, Fig. 14 marked "Back Tack". The machine will then stitch in a reverse direction, thus making it easy to "back tack" and to fasten ends of seams.

TO REGULATE PRESSURE ON PRESSER FOOT

For average materials, the pressure of the presser foot on the material seldom requires changing. Heavy materials require more pressure than light weight materials. The pressure should be only heavy enough to prevent side creeping of material and still obtain a uniform length of stitch.

To increase pressure, turn thumb screw X, Fig. 15 clockwise or downward. To lighten pressure, turn thumb screw X so that it screws upward.

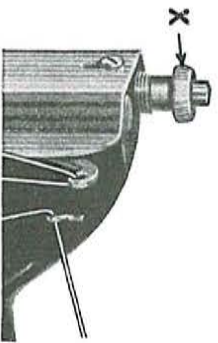

Fig. 15. Thumb Screw for Regulating Pressure on Presser Foot

Thread Tensions

For perfect stitching, the tension on needle and bobbin threads must be heavy enough to pull threads to center of thickness of material and make a firm stitch, as shown in Fig. 16.

If needle thread lies straight along top side of material, tension on needle thread is too heavy or tension on bobbin thread is too light, as shown in Fig. 17.

If bobbin thread lies straight along the underside of the material, tension on needle thread is too light or tension on bobbin thread is too heavy, as shown in Fig. 18.

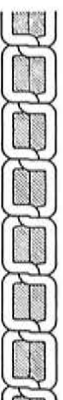

Fig. 16. Perfect Stitching



Fig. 17. Imperfect Stitching



Fig. 18. Imperfect Stitching

TO REGULATE NEEDLE THREAD TENSION

The tension on the needle thread can be tested only when the presser foot is down.

The numerals "0" to "9" on dial D, Fig. 19 indicate different degrees of tension that can be obtained. The numbers do not denote size of thread or ounces of tension.

When the tension has been correctly set, as described on pages 24 and 25, note number at indicator line Y, Fig. 19 so that this setting may be regained should the tension be altered for special work.

To increase tension, turn the thumb nut B gradually to the right (clockwise) until the required tension is obtained. Each higher number denotes increased tension.

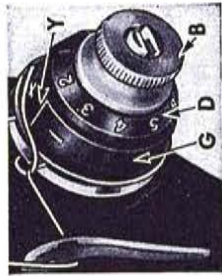

Fig. 19. To Regulate Needle Thread Tension

To decrease tension, turn thumb nut B gradually to the left (counter-clockwise) until the required tension is obtained. Each lower number denotes less tension.

The tension indicator G is marked with the signs + and -, which indicate the direction in which to turn thumb nut B for more or less tension.

TO REGULATE BOBBIN THREAD TENSION

The tension on the bobbin thread is regulated by screw A, Fig. 20 which is nearest center of tension spring on outside of bobbin case. To increase the tension, turn screw A over to the right. To decrease the tension, turn this screw over to the left.

When the tension on bobbin thread has been once properly adjusted, it is seldom necessary to change it, as a correct stitch can usually be obtained by varying tension on needle thread.

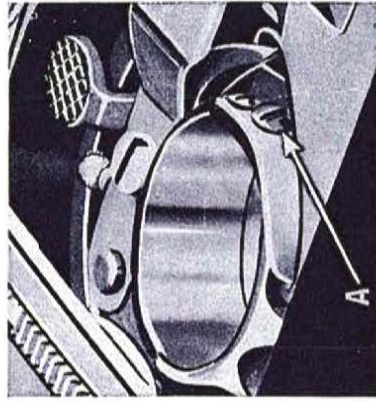

Fig. 20. Bobbin Thread Tension

TO REMOVE AND DISASSEMBLE NEEDLE THREAD TENSION

Turn thumb nut B, Fig. 21 to the left (counter-clockwise) until numeral "0" on numbered dial D stops at center line

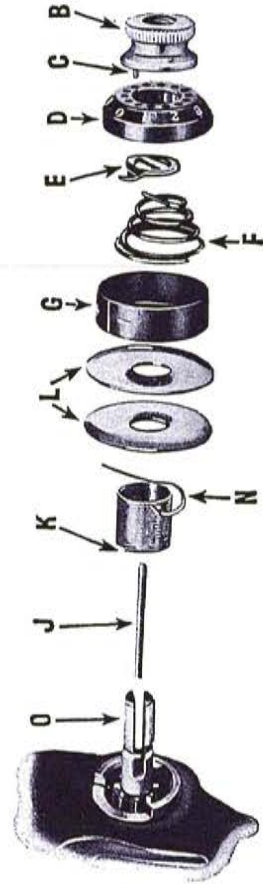

Fig. 21. Needle Thread Tension Disassembled

TO REASSEMBLE AND REPLACE NEEDLE THREAD TENSION

Make sure that tension releasing pin J is in place in stud O, then place thread take-up spring on stud, with tail (inside the coil) of this spring in one of the grooves T of stud, and with large loop N of spring resting against thread take-up spring regulator at M, Fig. 22.

Fig. 22 shows spring in correct position on stud. The tail of the spring is not visible in these illustrations, but its location inside the spring coil is indicated by K, Fig. 21.

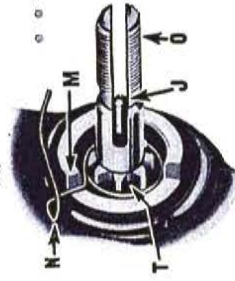

Fig. 22. Needle Thread Take-up Spring

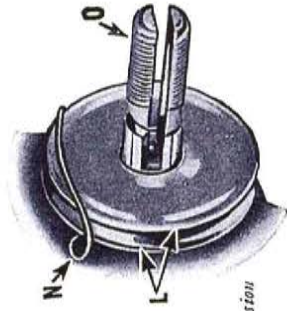

Fig. 23. Needle Thread Tension Discs Assembled

Place the two tension discs L, Fig. 21 with their flat thread-bearing sides together in position on stud O and with loop N of thread take-up spring straddling discs L, as shown in Fig. 23. Next replace indicator G, open side out, so that the plus and minus marks will be at the top with minus sign to the left. Then insert tension spring F in indicator with first (half) coil of spring straddling lower half of stud, as shown in Fig. 24. Place stop washer E on stud so that the extension will be above tension stud.

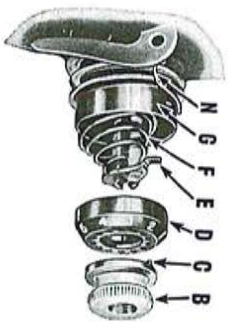

Fig. 24. Reassembling Needle Thread Tension

If spring and stop washer arc in correct position, extension S will clear first (half) coil of tension spring, as shown in Fig. 25.

24

Next place dial D on stud with numeral "2" opposite stop washer extension S, then push dial to compress spring, and at the same time screw thumb nut B on stud, carefully guiding pin C of thumb



Fig. 25. Stop Washer and Tension Spring

nut into one of the holes in dial D. Then lower presser bar and turn thumb nut B to left until "0" on dial D stops at centerline on indicator G. Thread the tension and pull thread through tension discs to test amount of tension on thread at the "0" position. At this point there should be a slight pull on the thread to indicate that there is a

25

minimum tension which gradually increases with the turning of thumb nut B to the right, providing a full range of tensions with one revolution of the thumb nut. If the pull is too strong for a minimum tension, press in dial D to disengage pin C on nut from dial, and reset pin in one of holes at left of previous setting. This resetting will produce less tension at "0". Repeat this process until minimum desired tension is obtained. If there is no tension at "0", press in dial D and reset pin C on nut in one of holes at right of previous setting, repeating this process until a slight minimum tension is obtained.

The tension on thread take-up spring N, Fig. 24 and stroke of this spring should be just sufficient to take up slack of needle thread until eye of needle reaches material in its descent.

If tension on thread take-up spring requires adjustment, disassemble needle thread tension, as instructed on page 22, and place end of spring N in groove which produces correct tension. Reassemble needle thread tension, as instructed on pages 23, 24, and 25.

IF CORRECT STITCHING IS NOT OBTAINED

If bobbin thread tension has been disturbed, or a correct stitch cannot be

obtained without a very heavy or very light needle thread tension, the following procedure is recommended.

Using No. 50 Mercerized thread in needle and on bobbin, adjust needle thread tension as instructed on page 25. Then turn tension thumb nut until No. 4 on dial is opposite centerline on indicator and, with two thicknesses of thin material in machine, adjust bobbin thread tension, as instructed on page 21, until stitch is correctly locked in material, as shown in Fig. 16.

A wide range of materials and threads can now be accommodated without further adjustment of bobbin thread tension.

TO OIL THE MACHINE

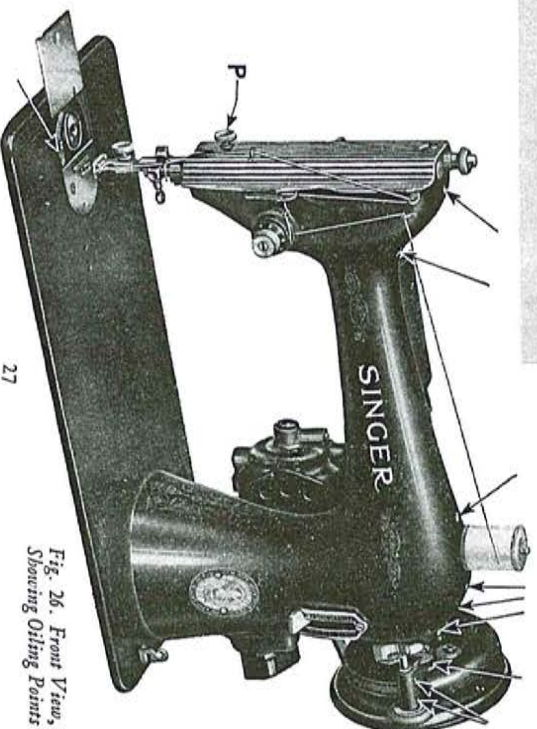

Fig. 26. Front View, Showing Oiling Points

27

If the machine is used continuously, it should be oiled daily. If moderately used, an occasional oiling is sufficient. Apply one drop of oil to each of the places indicated in Figs. 26, 27, and 28, and carefully clean the machine to insure smooth and satisfactory performance.

Take out thumb screw P, Fig. 26 near lower end of face plate, raise plate and slip it off over head of screw near upper end of plate; put one drop of oil into each of the oil holes and joints and then replace face plate.

To oil mechanism under slide, draw slide to the left (see Fig. 26) and, after removing lint and dust which may have

28

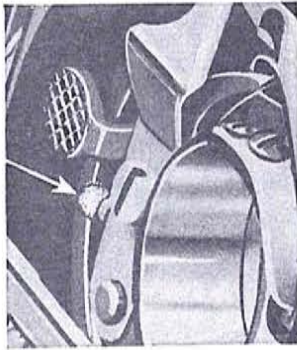

Fig. 27. Oiling the Sewing Hook

accumulated (see instructions on page 31), put a few drops of oil on the small piece of felt at the right of bobbin ejector, as indicated in Fig. 27. Then close the slide.

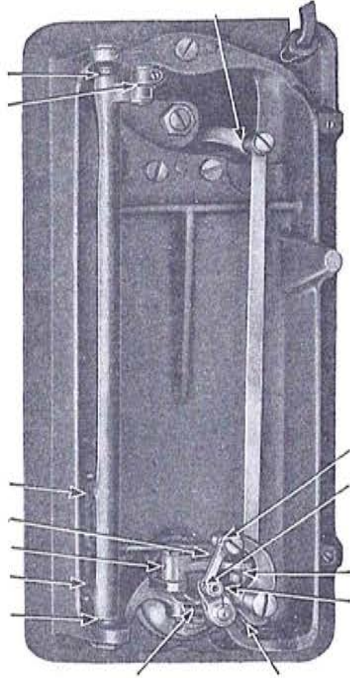

Fig. 28. Oiling Points in Base of Machine

To oil parts underneath bed of machine, turn machine back on its hinges and apply oil to oil holes and bearings indicated in Fig. 28.

29

TO LUBRICATE THE MOTOR

NEVER USE OIL OR ORDINARY GREASE FOR LUBRICATING THE MOTOR as they are harmful for this purpose. **USE ONLY SINGER* MOTOR LUBRICANT** from tube supplied. It is the only lubricant which will positively lubricate the motor.

When the machine is shipped from the factory, the two grease tubes H, Fig. 29 are filled with enough lubricant for approximately six months' use.

Refill grease tubes H at least once each six months by inserting tip of lubricant

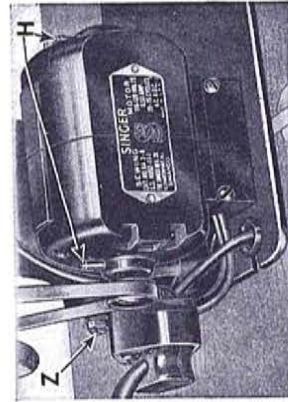

Fig. 29. Motor Lubricating Points

container into grease tubes and squeezing enough lubricant into each tube to fill it.

30

TO CLEAN THE STITCH FORMING MECHANISM

After considerable use, the stitch forming mechanism of the machine may become clogged with lint which may interfere with the perfect operation of the machine.

Occasionally remove the bobbin case from the machine, according to the following instructions, and remove any lint, etc., which has accumulated in the machine.

TO REMOVE BOBBIN CASE

Operator at the Front of the Machine

Raise needle to its highest position by turning hand wheel over toward you. Draw slide plate Q, Fig. 30 slightly to

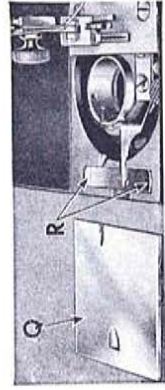

Fig. 30. Slide Plate Removed

31

TO REPLACE BOBBIN CASE

Operator at the Front of the Machine

See that the needle is raised to its highest position and that latch U, Fig. 33 is raised from slot X, Fig. 33 and moved toward you.

Hold bobbin case between forefinger and thumb of left hand, as shown in Fig. 32. Insert forked end of bobbin case under throat plate so that fork straddles end of bobbin case position bracket Y, Fig. 33. Then, with a slight twisting

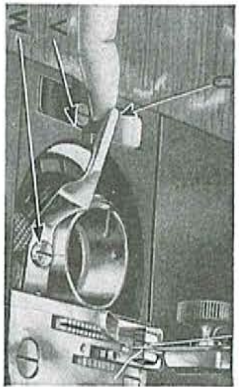

Fig. 31. Raising the Bobbin Case Latch

Under no circumstances must screw W be loosened. The loosening of this screw will change the clearance for thread between bobbin case and bobbin case position bracket.

Hold bobbin case between forefinger and thumb of left hand, as shown in

Fig. 32. Tilt the bobbin case to the left and at the same time slightly turn the right or forked end toward you so that it is moved out of engagement with sewing hook. Then tilt bobbin case toward the right and remove it.

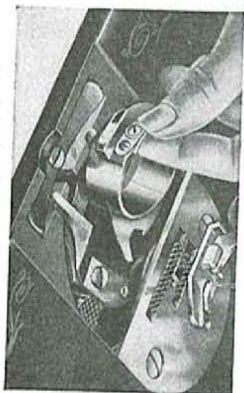

Fig. 32. Removing the Bobbin Case

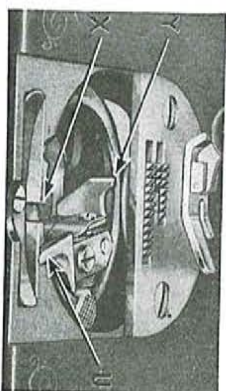

Fig. 33. Bobbin Case Position Bracket

SEWING SUGGESTIONS

Belt

See that the belt has the correct tension. This tension should be only enough to keep the belt from slipping. If the belt tension is incorrect, loosen screw Z, Fig. 29, page 30, about one turn and allow the motor to drop downward until the belt has the correct tension, then tighten screw Z.

Breaking of Needles Might be Caused by:

1. Wrong size needle for thread and material—see page 6.
2. Bent needle.

3. Pulling of material when stitching
4. Needle striking an incorrectly fastened presser foot or attachment.
5. Crossing thick seams with too small a needle.

Breaking of Needle Thread

Might be Caused by:

1. A knot in thread.
2. Incorrect threading—see page 13.
3. Upper tension is too tight—see page 19.
4. Needle not pushed up as far as it will go into needle clamp—see page 12.

motion of bobbin case to the left and to the back, lightly press it downward until edge of sewing hook engages in groove under rim of bobbin case.

Having set bobbin case into correct position, lock latch U, Fig. 33 in notch

X to hold bobbin case in place.

Then replace slide plate from the right, as shown in Fig. 34, making sure that the two ends of spring R center grooves on underside of slide plate.

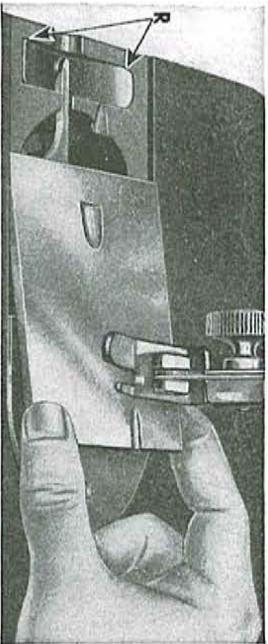

Fig. 34. Replacing the Slide Plate

5. Needle blunt or bent.
 6. Thread too coarse for needle—see page 6.
 7. Roughened hole in throat plate.
 8. Incorrect arrangement of threads to start sewing—see page 14.
- Breaking of Bobbin Thread Might be Caused by:**
1. Incorrect threading of bobbin case—see pages 10 and 11.
 2. Bobbin thread tension too tight—see page 21.

Skipping of Stitches Might be Caused by:

1. Needle not pushed up as far as it will go into needle clamp—see page 12.
 2. Needle blunt or bent.
 3. Needle too small for thread—see page 6.
- If machine runs heavily after standing idle for a long period, apply a few drops of kerosene to all oiling places, run machine for a few minutes, then wipe clean and oil—see pages 27, 28 and 29.

INSTRUCTIONS FOR USING

THE ATTACHMENTS

THE FOOT HEMMER

The foot hemmer may be used for hemming the edge of material, making hemmed and felled seams and for hemming and sewing on lace in one operation.

The foot hemmer is attached to machine in place of presser foot. Raise needle to its highest position, loosen thumb screw which clamps presser foot to presser bar and remove presser foot. Attach foot hemmer to the



Fig. 35.
The Foot Hemmer

bar, and tighten screw firmly. Pull up bobbin thread as instructed on page 14.

HOW TO START THE HEM AT THE VERY EDGE

There are several ways of starting the hem at the edge, but the most practical one is as follows:

1. Fold edge of material twice, about $\frac{1}{8}$ inch each time, for a distance of about two inches. Crease folds.
2. Lay about three inches of needle and bobbin threads back under hemmer. Place creased edge of material under hemmer with end of hem directly

under needle. Lower hemmer and tack end of hem with two machine stitches.

3. Raise hemmer. Pull threads and hem slightly from you with left hand, then, while holding threads, draw material toward you with right hand into scroll of hemmer until tacked end is caught in hemmer, as shown in Fig. 36.
4. Lower hemmer and begin to sew, slightly pull threads back while sewing. Keep mouth of hemmer full to produce a smooth, even hem, as shown in Fig. 37.

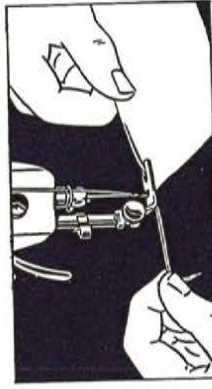

Fig. 36. Starting a Hem at the Edge

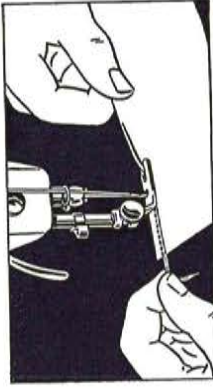

Fig. 37. Hemming Edge of Material and Pulling Back Threads While Sewing

MAKING A HEMMED SEAM WITH THE FOOT HEMMER

See Figs. 38 and 39

1. When making this seam, the garment must first be fitted and edge of material trimmed, allowing for about $\frac{1}{8}$ inch seam. Insert the two edges of material, right sides together, in hemmer in same manner as a single hem, as shown in Fig. 38. If material is bulky, place edge of upper piece of material about $\frac{1}{8}$ inch to left of edge of under piece.
2. The free edge of hemmed seam may be stitched flat to garment, if desired. To do this, open work out flat, wrong side up, then insert hem in scroll of hemmer, holding edge of hem in position while it is being stitched. If seam is stitched flat to garment, one row of stitching is visible on the right side.

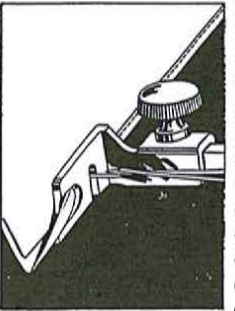

Fig. 38. Making a Hemmed Seam (First Operation)

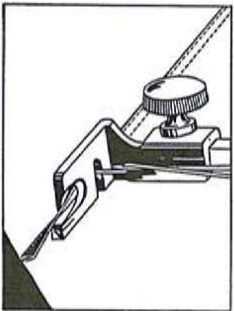

Fig. 39. Making a Hemmed Seam (Second Operation)

MAKING A FILLED SEAM WITH THE FOOT HEMMER

See Figs. 40 and 41

1. Place right sides of material together, with edge of upper piece about $\frac{1}{8}$ inch to left of edge of under piece. Stitch the two pieces together, using

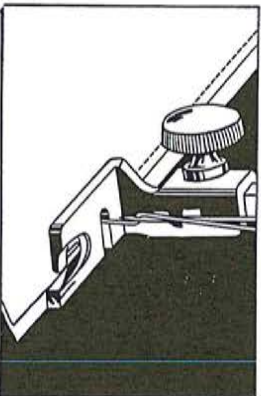

Fig. 40. Making a Filled Seam (First Operation)

hemmer as a presser foot. Guide both pieces by the projecting toe of hemmer, as shown in Fig. 40.

2. Open work out flat, wrong side up, and hem free edge of seam, stitching it flat to garment, as shown in Fig. 41.

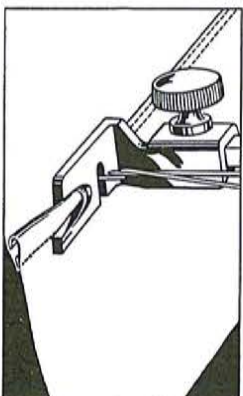

Fig. 41. Making a Filled Seam (Second Operation)

TO HEM AND SEW ON LACE IN ONE OPERATION

See Fig. 42

1. Start hem in the regular way.
2. Hold hem in position with needle.
3. Raise presser bar and insert edge of lace in slot of hemmer and back under hemmer.
4. Lower presser bar and start sewing, catching edge of lace with needle.
5. Guide hem with the right hand and lace with the left hand, being careful not to stretch lace as it enters hemmer.

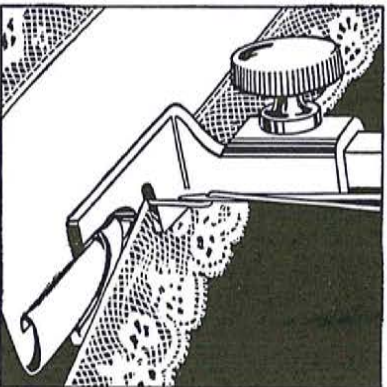

Fig. 42. Hemming and Sewing on Lace in One Operation

ADJUSTABLE HEMMER

Making Hems From $\frac{3}{16}$ To $1\frac{5}{16}$ Inch Wide

See Fig. 43

1. Attach adjustable hemmer to presser bar in place of presser foot.
2. Pull up bobbin thread, as instructed on page 14.
3. Loosen thumb screw on hemmer and move scale until point registers with number of desired width of hem, No. 1 indicating narrowest hem and No. 8 the widest, then tighten thumb screw.
4. Place cloth in hemmer and draw it back and forth until hem is formed, as shown in Fig. 43.

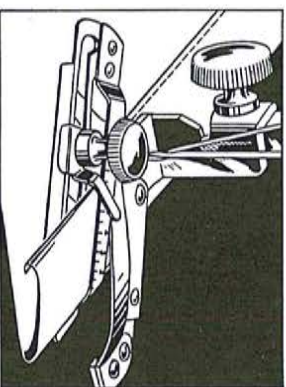

Fig. 43. Showing How Adjustable Hemmer is Used for Making Hems up to $1\frac{5}{16}$ Inch Wide

MULTI-SLOTTED BINDER

This multi-slotted binder will apply unfolded bias binding $\frac{1}{16}$ inch in width and commercial folded binding in sizes 1, 2, 3, 4 and 5, to the seams or to the edges of garments. These sizes of folded binding are $\frac{1}{4}$, $\frac{3}{16}$, $\frac{1}{2}$, $\frac{3}{8}$, $\frac{7}{16}$ and $\frac{1}{2}$ inch in width, respectively, and are fed through slots of corresponding sizes in the binder scroll. (See Fig. 44.) Binding may be purchased in a variety of materials and colors.

For convenience in determining the correct width of unfolded binding ($\frac{1}{16}$ inch), this measurement is marked on the binder, as shown in Fig. 44.

44

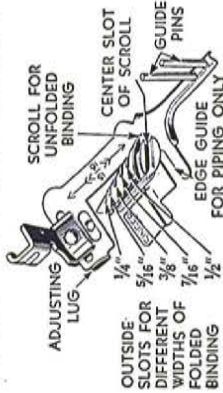

Fig. 44. The Multi-Slotted Binder

The two upright guide pins shown in Fig. 44 eliminate manual guiding of the binding.

The wide range of bindings that can be applied with this binder makes it useful for a large variety of work. It will be found particularly advantageous for making children's wear, lingerie, summer dresses, and other dainty articles which call for the narrower bindings.

45

As two different widths of binding of contrasting colors can be fed through the binder at the same time, attractive binding and piping effects can be produced in one operation.

TO ATTACH THE BINDER

Raise the needle to its highest position, then attach the binder to the presser bar in place of the presser foot. See that the needle enters the center of the needle hole.

TO INSERT THE BINDING IN THE BINDER

Cut all binding to a long point to the left, as shown in Fig. 45. Folded Bias Binding must be inserted in the slot or slots of corresponding sizes (See Fig. 48.)

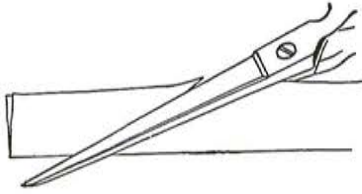

Fig. 45

Unfolded or Raw Edge Bias Binding must be inserted in the open end of the scroll. (See Fig. 46.)

After inserting the pointed end of the binding in the binder, push it through until the full width of the binding is under the needle.

Guide the binding by means of the two upright pins, as shown in Figs. 46 to 50.

46

TO INSERT THE GARMENT IN THE BINDER

Place the edge to be bound as far to the right as it will go in the center slot of the scroll, as shown in Fig. 46, and draw it back under the binder foot.

Lower the binder by means of the presser foot lifter, and start to sew. Keep the material well within the center slot of the scroll so that the edge will be caught in the binding.

TO ADJUST THE BINDER

To bring the inner edge of the binding closer to the stitching, move the scroll C2, Fig. 46 to the right by means of

46

PIPED EDGE

To produce a piped edge on garments, move the lug B2, Fig. 47 to the left to bring the stitching about midway of the folded binding.

Crease the raw edges of the garment

toward the wrong side about $\frac{1}{8}$ inch, and insert the folded edge, raw edges up, into the edge guide on the binder and beneath the binding.

When stitched, both sides of the garment will be finished, and the right side will show the piped edge.

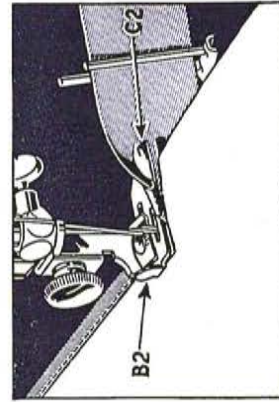

Fig. 46. Binding with Unfolded Binding

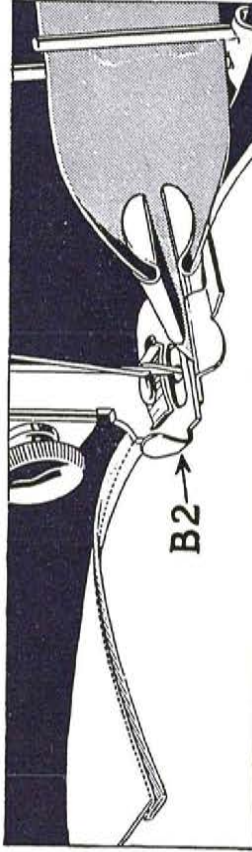

Fig. 47. Position of Garment and Binding When Piping Edges

47

PIPING AND BINDING IN ONE OPERATION

A garment can be piped and bound in one operation, as shown in Fig. 48.

IMPORTANT:—When piping and binding at the same time, as shown in Fig. 48, insert narrow width of binding first in its slot, then insert wider width in its slot. Two consecutive widths should not be used at the same time. That is, if No. 1 is used, the wider binding should not be smaller than No. 3. If No. 2 is used, the wider binding should not be less than No. 4. Never use Nos. 1 and 2, or 2 and 3, etc., together.

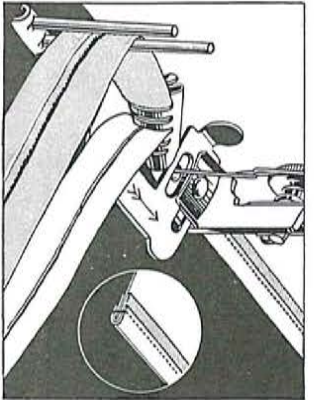

Fig. 48. Piping and Binding in One Operation

Use upright guide pins to guide the wider of the two widths of binding, as shown in Fig. 48.

48

TO BIND OUTSIDE CURVES

See Fig. 49

Allow edge to be bound to pass freely through scroll without crowding against scroll wall. The material must be guided from back of binder and to the left, permitting unfinished edges to swing naturally into scroll of binder.

Never pull binding while it is being fed through binder, as this may stretch binding, making it too narrow to stitch or to turn in the edges.

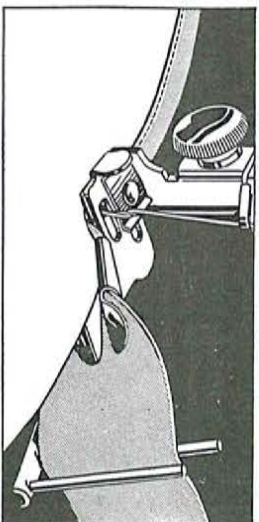

Fig. 49. Binding on Outside Curve

49

THE EDGE-STITCHER

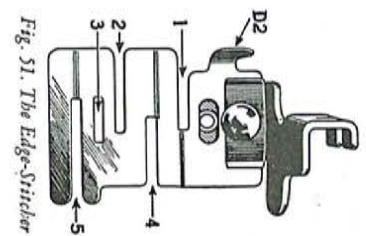

Fig. 51. The Edge-Stitcher

will be found an indispensable aid whenever stitching must be kept accurately on extreme edge of material. The slots, numbered from 1 to 5 in Fig. 51, serve as guides for sewing together laces, insertions and embroideries, sewing in position hemmed or folded edges, piping or sewing flat braid to a garment.

ADJUSTING THE EDGE-STITCHER

Fasten edge-stitcher to presser bar. See that needle enters center of needle hole. The distance from line of stitching to edge of material in slots can be regulated by moving lug D2, Fig. 51 to the right or left.

If lug is difficult to move, put a drop of oil under the blue spring, then wipe it dry.

For guidance in applying rows of French folds, mark material with a line of basting stitches or with chalk or pencil.

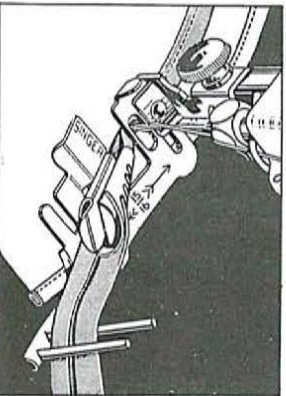

Fig. 50. Applying a French Fold

50

TO APPLY FRENCH FOLDS TO CURVES

Place material under binder and stitch binding onto face of material, as shown in Fig. 50.

50

51

SEWING LACE TOGETHER WITH THE EDGE-STITCHER

It is difficult to sew two lace edges together, even after basting, but the edge-stitcher makes it possible to stitch on the very edge.

1. Insert one of the laces in slot 1 and the other in slot 4.
2. Adjust lug D2 until both edges are caught by the stitching.
3. Hold the two pieces slightly overlapped to keep them against the ends of the slots.
4. Loosen both thread tensions to avoid puckering of fine lace.

TO INSERT LACE OR RIBBON

1. Fold edge of material to which lace or ribbon is to be sewn and insert it

in slot 1 of edge-stitcher.

2. Insert lace or ribbon in slot 4 of edge-stitcher and proceed to sew.
3. Cut away surplus folded material close to stitching.

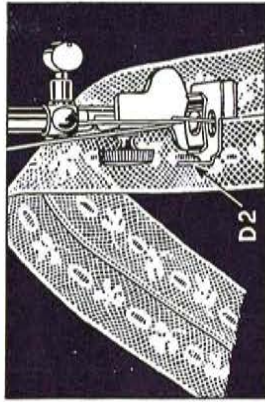

Fig. 52. Sewing Lace Together

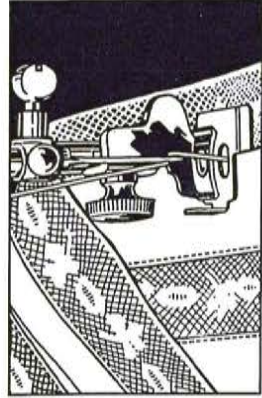

Fig. 53. Setting in Lace Insertion

PIPING WITH THE EDGE-STITCHER

See Fig. 54

Piping is very attractive if the correct contrasting color is chosen for the piping material.

1. Cut piping bias and twice width of slot 3 so that it can be folded once.

2. Insert piping with its folded edge to the left in slot 3 and edge to be piped in slot 4, Fig. 51.

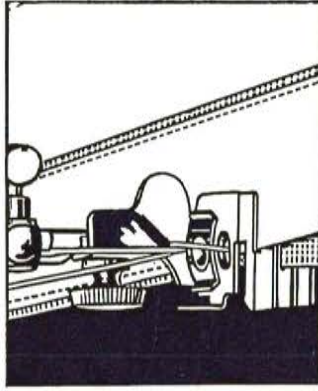

Fig. 54. Piping with the Edge-Stitcher

APPLYING FOLDED BIAS TAPE OR MILITARY BRAID

1. Place garment under edge-stitcher and tape in slot 1 or 4, Fig. 51.
2. To make square corners, sew to turning point, remove tape from attachment, form corner by hand, replace tape and continue stitching.
3. To space two or more parallel rows, mark material with a guide line, using a crease, chalk mark or basting thread.

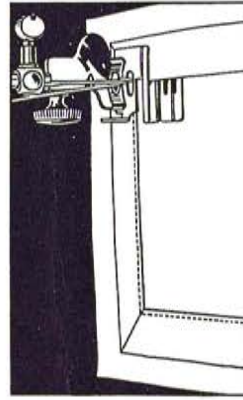

Fig. 55. Applying Bias Folded Tape

STITCHING A WIDE HEM WITH THE EDGE-STITCHER

A wide hem on sheets, pillow slips, etc., may be stitched evenly with the edge-stitcher.

1. Measure hem and turn edge.

2. Insert edge in slot 5, Fig. 51 and adjust lug D2 to stitch as close to edge as desired.

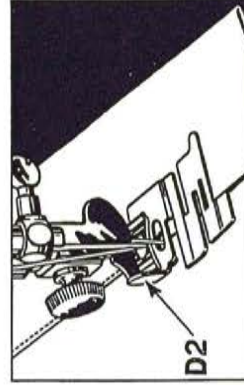

Fig. 56. Making a Wide Hem

MAKING A FRENCH SEAM

1. To make a uniform width French seam, insert two edges to be joined,

wrong sides together, in slot 1 or 2 and stitch close to edge.

2. Fold both right sides together and insert back of seam in slot 1 and stitch, allowing just enough margin to conceal raw edges, as shown in Fig. 57.



Fig. 57. Making a French Seam (Second Operation)

TUCKING WITH THE EDGE-STITCHER

See Fig. 58

Dainty narrow tucking, up to a maximum width of $\frac{1}{8}$ inch, may be produced with the edge-stitcher.

1. Fold and crease material for desired width of tuck.
2. For succeeding tucks, fold material the desired distance from previous tuck, running fold lengthwise over a straight edge, then crease folds.
3. Insert creased folds in slot 1, Fig. 51 and adjust edge-stitcher to the right or left for desired width of tuck.

The secret of good tucking lies in a light tension, short stitch, and fine needle and thread.

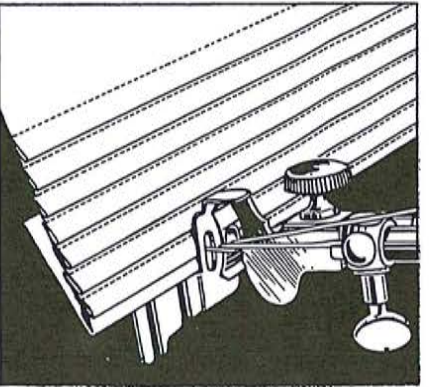

Fig. 58. Tucking with the Edge-Stitcher

56

THE GATHERING FOOT

TO SHIRT WITH THE GATHERING FOOT

1. Fasten gathering foot to presser bar in place of presser foot.
2. Place material under gathering foot and stitch in the usual way.

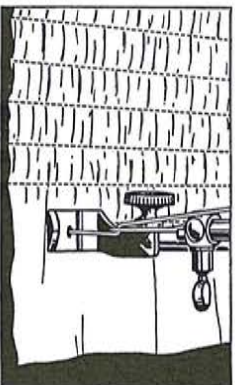

Fig. 59. The Gathering Foot in Operation

3. The fullness of shirting or amount of gathering is regulated by length of stitch. A longer stitch increases fullness of gathers.

With gathering foot, it is possible to shirt in narrow rows, as shown in Fig. 59. The material may be guided as easily as when sewing with presser foot. Fine materials, such as batiste, silk or net, may be very attractively shirred, as shown by sample in Fig. 60.

57

RUFFLER

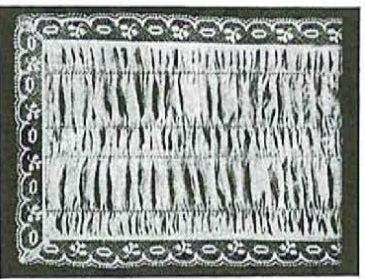

Fig. 60. Shirring

A very pleasing effect may be gained by using thread or embroidery silk of contrasting color on the bobbin. Fig. 61 shows a white organdy collar and cuff

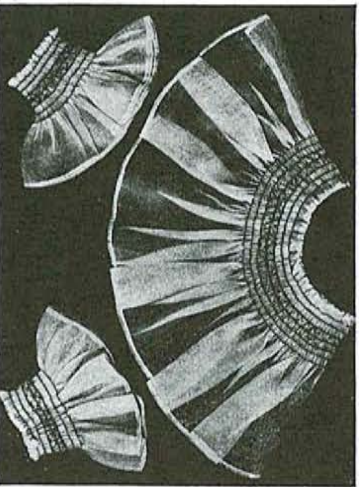

Fig. 61. Smocking

set with red and green smocking made with the gathering foot, using fine crochet cotton or tating thread on top and white cotton on the bobbin.

58

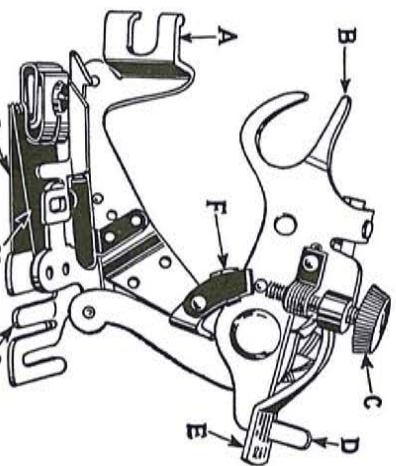

Fig. 62. Principal Parts of the Ruffler

Principal Parts of the Ruffler

- A—Foot—attaches ruffler to presser bar.
- B—Fork Arm—straddles needle clamp.
- C—Adjusting Screw—regulates fullness of gathers.
- D—Projection—engages slots in adjusting lever.
- E—Adjusting lever—sets ruffler for gathering or for making a pleat once at every six stitches or once every twelve stitches, as desired; also for disengaging ruffler, when either pleating or gathering is not desired.
- F—Adjusting Finger—regulates width or size of pleats.

59

G—Separator Guide—contains slots into which edge of material is placed to keep heading of ruffle even; also for separating material to be ruffled from material to which ruffle is to be attached.

H—Ruffling Blade—pushes material in pleats up to needle.

J—Separator Blade—prevents teeth of ruffling blade from coming into contact with feed of machine or material to which ruffle or pleating is to be applied.

TO ATTACH THE RUFFLER TO THE MACHINE

1. Raise needle to its highest point.
2. Loosen presser foot thumb screw and attach ruffler to presser bar in place of presser foot, at the same time placing fork arm B astride needle clamp.

60

3. See that needle enters center of needle hole in ruffler.

TO ADJUST RUFFLER FOR GATHERING

1. Swing adjusting finger F away from needle.
2. Raise adjusting lever E and move it until projection D can be entered in slot marked "1".



Fig. 63. Gathering with the Ruffler

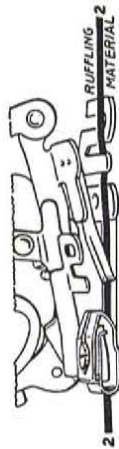

Fig. 64. Correct Position for Material to be Ruffled

3. Insert material to be ruffled between two blue blades and under separator guide (Line 2, Fig. 64).
4. Draw material slightly back of needle, lower presser bar and start to sew.
5. For fine gathering, turn adjusting screw C upward to shorten stroke. Set machine for a shorter stitch.
6. For full gathering, turn adjusting screw C downward to lengthen stroke. Set machine for a longer stitch.

61

TO MAKE A RUFFLE AND SEW IT TO A GARMENT IN ONE OPERATION

1. Insert material to be ruffled between two blue blades and under separator guide (Line 2, Fig. 66).

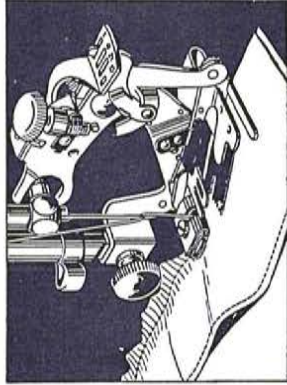

Fig. 65. Making a Ruffle and Attaching it in One Operation

2. Place material to which ruffle is to be attached under separator blade and under separator guide (Line 1, Fig. 66).
3. Proceed the same as for plain gathering.



Fig. 66. Correct Positions for Materials

TO MAKE A RUFFLE AND ATTACH IT WITH A FACING IN ONE OPERATION

1. Insert material to be ruffled between two blue blades and under separator guide (Line 2, Fig. 68).

62

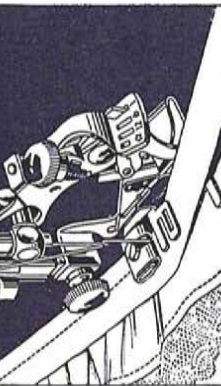

Fig. 67. Making a Ruffle and Attaching it with a Facing in One Operation

2. Place material to which ruffle is to be attached under separator guide (Line 1, Fig. 68).
3. Place facing material over upper blue blade (Line 4, Fig. 68).
4. If facing is to be on right side of garment, place wrong sides of the garment and the ruffle together.

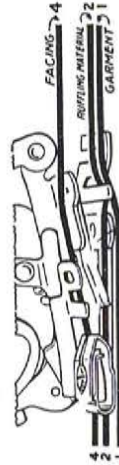

Fig. 68. Correct Position for Materials

5. If facing is to be on wrong side, place right sides of the garment and the ruffle together.

TO PIPE A RUFFLE

1. Insert material to be ruffled between two blue blades from the right (Line 3, Fig. 70). This material must not exceed 1 1/4 inches in width.
2. The piping material is usually cut on the bias and it should be about 1/4 inch wide when folded in center.

63

Place piping material in ruffler, following Line 5, Fig. 70 with folded edge of piping to right.

3. Fold edge of material to which piping and ruffling are to be attached and insert it in ruffler, from the left following Line 6, Fig. 70.

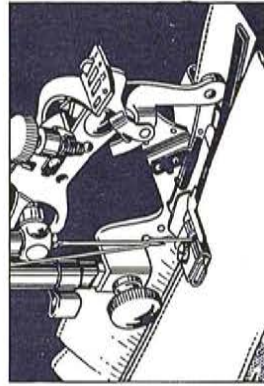

Fig. 69. Piping a Ruffle

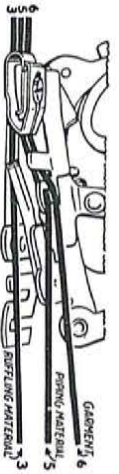

Fig. 70. Correct Positions for Materials

2. Insert the material to be pleated between the two blue blades and under the separator guide (Line 2, Fig. 72).
3. To increase width of pleat, move adjusting finger F back toward needle and turn adjusting screw C downward.

- TO ADJUST RUFFLER FOR PLEATING**
1. Raise adjusting lever E and move it until projection D can be entered in slot marked "6". The ruffler will then pleat once every six stitches. To pleat once every twelve stitches, have projection D enter slot "12" in the adjusting lever E.

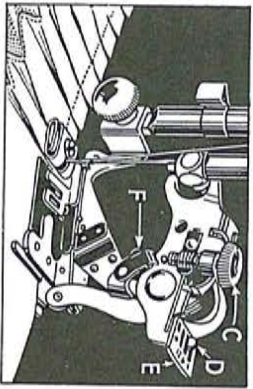

Fig. 71. Pleating with the Ruffler

64

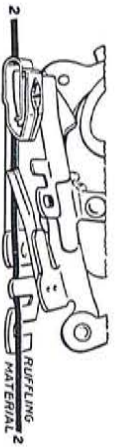

Fig. 72. Correct Position for Material

2. When the desired space is made, set projection D in either of slots "6" or "12".

To make a smaller pleat, turn adjusting screw C upward. The distance between pleats is regulated by length of stitch.

TO ADJUST RUFFLER FOR GROUP PLEATING

1. To make the space between the groups of pleats, raise adjusting lever E and move it until projection D can be entered in small slot indicated by star on adjusting lever E. The ruffler

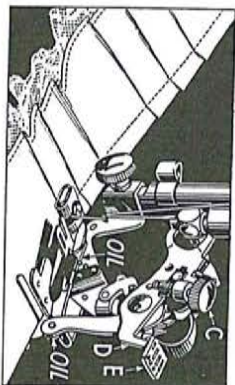

Fig. 73. Group Pleating with the Ruffler

65

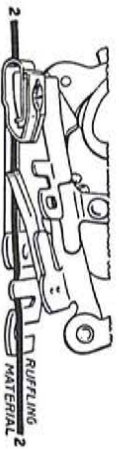

Fig. 74. Correct Position for Material

3. Insert the material to be pleated between the two blue blades and under the separator guide (Line 2, Fig. 74).

TO OIL THE RUFFLER

Occasionally apply a drop of oil to working parts of ruffler at places indicated in Fig. 73.

DARNING OR EMBROIDERING

While embroidery and darning can be done on machine when threaded for regular sewing, the use of feed cover plate L, Fig. 75, No. 32622 is recommended, as movable contact with feed in some cases might interfere with handling of work.

Do not change adjustment of feed dog in any way, as it is essential that its position should remain as originally fixed.

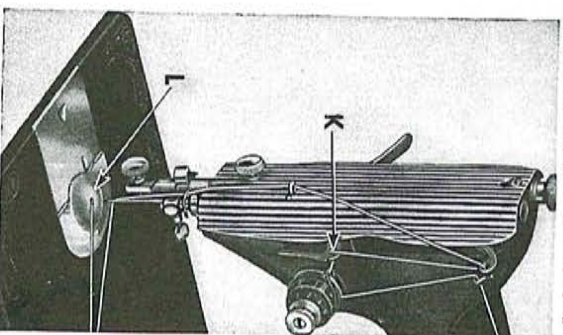

Fig. 75. Machine Threaded for Embroidery and Darning

67

When feed cover plate L, Fig. 75 is used, it is necessary to lead needle thread through eye in thread regulator K, Fig. 75 at left of tension discs and not under the thread regulator. With this exception, the threading is the same as for regular sewing (see Fig. 11, page 13).

Remove presser foot and let down presser bar lifter to restore tension on needle thread, which is released and inoperative when lifter is raised.

To attach feed cover plate, draw the slide to the left. Position feed cover

plate on top of throat plate, sliding it under needle from left to right. The downwardly projecting hooks on feed cover plate will grasp edge of throat plate. When slide is closed, feed cover plate is held firmly in position. Test for accurate positioning of feed cover plate by slowly turning hand wheel until needle moves down and up again and take-up lever is brought to its highest position, as shown in Fig. 75.

Feed cover plates are not included in the regular set of attachments, but they are on sale at all **SINGER SEWING CENTERS**.

INDEX

Adjustable Hemmer	43
Attachments	
Binder, Multi-Slotted	44
Edge-Stitcher	51
Gathering Foot	57
Hemmer, Adjustable	43
Hemmer, Foot	38
Ruffler	59
Bobbin	
To Remove	7
To Replace	10
To Wind	7
Bobbin Thread Tension	
To Regulate	21
Darning Or Embroidering	67
Direction of Feed	
To Regulate	18
Edge-Stitcher	51
Electrical Information	
Electrical Connection	4
Electric Motor	4
The Light	5
Foot Hemmer	38
Gathering Foot	57
Lubrication	
To Oil the Machine	27
To Oil the Sewing Hook	28
To Lubricate the Motor	30
Length of Stitch	
To Regulate	17
Multi-Slotted Binder	44
Needles and Threads to Use	6
Needle Setting	12

THE IMPORTANCE OF USING SINGER NEEDLES AND SINGER LUBRICANTS FOR YOUR SEWING MACHINE

NEEDLES

You will obtain the best stitching results from your sewing machine if it is fitted with a SINGER Needle.

SINGER Needles can be purchased from any SINGER Shop or SINGER salesman.

SINGER Needles are contained in the SINGER Green Needle Packet with the famous red letter "S" upon it.

USE SINGER OIL ON MACHINE

Knowing from many years' experience the great importance of using good oil, SINGER sells an extra quality machine oil, especially prepared for sewing machines.

USE SINGER MOTOR LUBRICANT ON MOTOR

The SINGER MOTOR LUBRICANT is especially prepared for lubricating the bearings of the electric motor. This is a pure non-flowing compound which retains its consistency and possesses high lubricating qualities.

INDEX

Needle Thread Tension	
To Regulate	20
To Remove and Disassemble	22
To Reassemble and Replace	23
Presser Foot	
To Regulate Pressure on Material	18
Ruffler	59
Service	3
Sewing	
To Prepare for Sewing	14
To Start Sewing	15
To Turn a Corner	16
Basting	16
To Sew Bias Seams	16
To Remove the Work	17
Thread Tensions	
To Regulate Needle Thread Tension	20
To Regulate Bobbin Thread Tension	21
To Remove and Disassemble Needle Thread Tension	22
To Reassemble and Replace Needle Thread Tension	23
Threading	
Bobbin Case Threading	10
Upper Threading	13
To Regulate Length of Stitch	17
To Regulate Direction of Feed	18
Sewing Suggestions	35