



FOR YOUR PROTECTION!

SINGER sells its machines only through SINGER SEWING CENTERS, identified by the Red "S" on the window, and never through department stores or other outlets.

When your machine needs servicing, call your SINGER SEWING CENTER and be sure of warranted SINGER parts and service.

Check local SINGER address in phone book.

SINGER SEWING MACHINE COMPANY

Form 20334
Rev. (352)

INSTRUCTIONS FOR USING SINGER ELECTRIC SEWING MACHINE 66-18

LOCK STITCH, FOR FAMILY USE
ADJUSTABLE REVERSE FEED
FOR TACKING

WHEN REQUIRING
NEEDLE, OIL,
PARTS OR
REPAIRS FOR
YOUR MACHINE



LOOK FOR THE
RED "S"
THERE ARE
SINGER SHOPS
IN EVERY CITY

THE SINGER MANUFACTURING COMPANY

Printed in U. S. A.

THE IMPORTANCE OF USING
SINGER* LUBRICANTS FOR
YOUR ELECTRIC SEWING MACHINE

"The Best is the Cheapest"

Use **SINGER SEWING MACHINE**
OIL on Machine

Knowing from many years' experience the great importance of using good oil, SINGER sells an extra quality sewing machine oil, in cans, especially prepared for sewing machines.

Use **SINGER MOTOR LUBRICANT**
on Motor

The **SINGER MOTOR LUBRICANT** is especially prepared for lubricating the bearings of the electric motor. This is a pure non-flowing compound which retains its consistency and possesses high lubricating qualities.

20334

INSTRUCTIONS
FOR USING

SINGER*

ELECTRIC SEWING MACHINE

66-18

OSCILLATING HOOK, FOR FAMILY USE

ADJUSTABLE REVERSE FEED
FOR TACKING

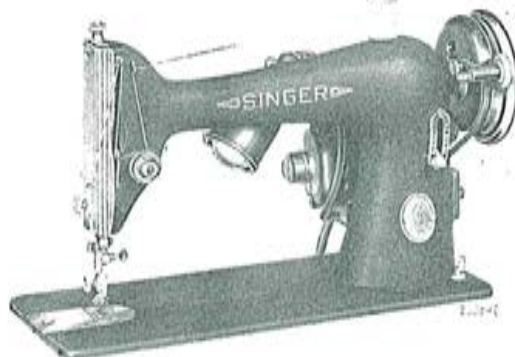

MACHINE 66-18

* A TRADE MARK OF

THE SINGER MANUFACTURING COMPANY

TO ALL WHOM IT MAY CONCERN:

The improper placing or renewal of the Trade Mark "**SINGER**" or any other of the Trade Marks of The Singer Manufacturing Company (all of which are duly Registered Trade Marks) on any machine that has been repaired, rebuilt, reconditioned, or altered in any way whatsoever outside of a SINGER factory or an authorized SINGER agency is forbidden.

Copyright, U. S. A.,
1915, 1923, 1924, 1926, 1928, 1929, 1931, 1932, 1933, 1935,
1937, 1938, 1940, 1941, 1947 and 1951
by The Singer Manufacturing Company
All Rights Reserved for All Countries

SINGER Needles should be used
in **SINGER** Machines.
These Needles and their Containers
are marked with the
Company's Trade Mark "**SIMANCO**,"**1

Needles in Containers marked
"**FOR SINGER MACHINES**"
are NOT **SINGER** made needles. 2

DESCRIPTION

Machine 66-18, for family use, has an oscillating sewing hook on a vertical axis and makes the lock stitch.

Back tacking is easily done on this machine after moving the stitch regulating lever to the upper end of the stitch indicator slot to reverse direction of stitching as instructed on page 18.

The machine is especially designed for operation by electricity, having an efficient electric motor attached to the upright part of its arm. The motor drives the machine through a belt and the speed is regulated by a combination knee and foot controller.

It is also equipped with an electric spotlight.

Embroidering and darning are accomplished as instructed on pages 57 and 58.

SINGER SERVICE

Now that you have purchased your new **SINGER** we do not want you to feel that your relations with us have come to an end. You are cordially invited to visit your **SINGER** Shop at any time for assistance in your sewing problems. You will be most welcome.

We hope, too, that you will make the **SINGER** Shop your headquarters for sewing supplies and service. Only there or through authorized bonded **SINGER** representatives can you secure warranted **SINGER** sewing machine oil, needles, belts, parts, etc., so important in getting the best results from your machine. And remember, only an authorized **SINGER** representative should be allowed to touch your machine when repairs or adjustments are required.

World-wide **SINGER** Service has no equal. Use it!

Motor Can be Operated on Either Alternating Current or Direct Current

The electric motor, which is located at the back of the machine, can be operated on either alternating current or direct current as desired. The standard windings of the motor are for 110-120 volts, and motors can be furnished for any voltage between 95 and 250.

Special motors for 32 volts direct current, and for 50 volts alternating current and direct current, have also been developed and are available.

Points to Determine Before Connecting Motor to Electric Service Line

Obtain the following information from the Electric Light Company which supplies the electric current for the circuit to which the motor is to be connected.

1. If current is direct, what is the voltage? The voltage must be within the range stamped on the name plate of the motor.
2. If current is alternating, in addition to the voltage, what is the number of cycles? The number of cycles must be within the range stamped on the name plate of the motor.

The voltage of any circuit and, if alternating current, the number of cycles, can be verified by looking at the name plate on service watt meter installed by the local Electric Light Company.

To Connect the Machine to Electric Service Line

Attach the terminal plug at the end of the electric cord to the nearest electric outlet and the machine is ready for operation.

To Turn the Spotlight "On" or "Off"

Reach over the top of the machine and turn the knurled switch (F, Fig. 2) in a clockwise direction.



FIG. 2

To Remove and Replace the Bulb

First remove the lens (G, Fig. 2) from the spotlight shade by turning the lens to disengage the lugs on the lens from the lugs on the inside of the shade, and the lens will drop out.

The bulb is removed by unscrewing it from its socket in the spotlight. To replace, screw the bulb into the socket, then replace the lens.

When purchasing a new bulb, specify No. 195148 and the voltage of your electric supply.

CAUTION

When you have finished your sewing, always disconnect the plug from the electric outlet.

To Insure Perfect Action of the Machine

When turned by hand, the balance wheel must always turn over toward the operator.

Do not run the machine with the presser foot resting on the feed without cloth under the presser foot.

Do not run the machine when both bobbin case and needle are threaded, unless there is material under the presser foot.

Do not try to help the machine by pulling the fabric, lest you bend the needle. The machine feeds the work without assistance.

The slide over the bobbin case should be kept closed when the machine is in operation.

Instructions for Operating the Machine

Raise the presser foot (X) by means of the presser bar lifter (Z) to prevent injury to the foot (X) and feed (W).

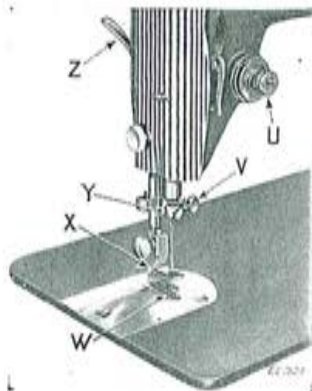

FIG. 3. FRONT VIEW OF THE MACHINE

Place a piece of cloth under the presser foot and let the foot down upon it.

To Start the Machine

After connecting the electric cord to the outlet, press the knee controller to the right or depress the foot controller. As the pressure on the knee controller or foot controller is increased, the speed of the machine is increased, the speed being controlled entirely by the amount of pressure on the controller. Operate the machine in this way, without being threaded, until you have become accustomed to guiding the material and operating the knee or foot controller.

To Take Out the Bobbin

Draw to the left the slide in the bed of the machine and press the forefinger of the right hand

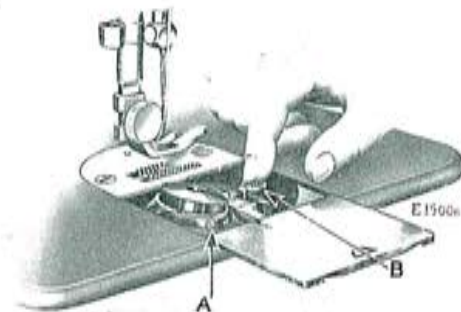

FIG. 4. REMOVING THE BOBBIN

upon the bobbin ejector (B, Fig. 4); this will raise the Bobbin so that it can easily be taken out.

SINGER Needles should be used
in **SINGER** Machines.
These Needles and their Containers
are marked with the
Company's Trade Mark "SIMANCO."*1

Needles in Containers marked
"FOR SINGER MACHINES"
are NOT **SINGER** made needles. 2

To Wind the Bobbin

It is necessary to understand the stop motion (Q, Fig. 5) by which the balance wheel (P) can be

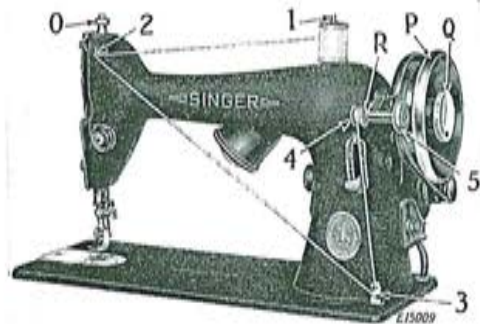

FIG. 5. MACHINE THREADED FOR WINDING THE BOBBIN

released when required, thus permitting the winding of bobbins without running the stitching mechanism.

To release the balance wheel (P), turn the stop motion screw (Q) over toward you. It is necessary to hold the balance wheel while loosening the stop motion screw.

Place the Bobbin on the bobbin winder spindle (R) and push it on as far as it will go. Put the spool of

thread on the spool pin (1) and pass the thread from the spool pin into the thread guide (2), then down and to the right into the lower notch of the bobbin winder thread guide (3) at the front of the machine bed, then around the back of this guide and into its upper notch, then up and through the hole in the left side of the Bobbin (4) from the inside. Press the bobbin winder pulley (5) down against the hub of the balance wheel. Press the knee controller or depress the foot controller as for sewing.

The end of the thread must be held by hand until a few coils are wound and should then be broken off. Fig. 5 shows the bobbin winder properly threaded and in position for winding. When sufficient thread has been wound upon the Bobbin, pull the bobbin winder pulley away from the balance wheel and remove the Bobbin from the spindle.

If the thread does not wind evenly on the Bobbin, loosen the screw which holds the bobbin winder thread guide (3) in position on the bed of the machine, and turn this guide to the right or left, as may be required, then tighten the screw.

To Replace the Bobbin

Hold the Bobbin between the thumb and forefinger of the left hand, the thread leading on top from the right toward the left, as shown in Fig. 6.

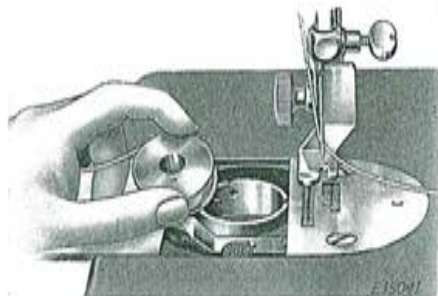

FIG. 6. REPLACING THE BOBBIN

Place the Bobbin into the bobbin case and draw the thread into the slot (1, Fig. 7) in the bobbin case, as shown below.

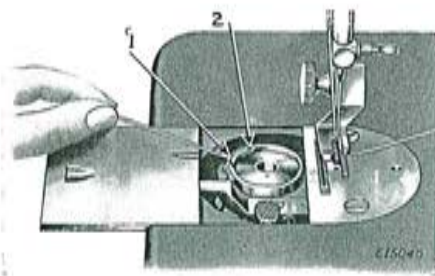

FIG. 7. THREADING THE BOBBIN CASE

Draw the thread backward between the bobbin case and the tension spring until it reaches the notch (2, Fig. 8), then pull the thread toward the right, as shown in Fig. 8.

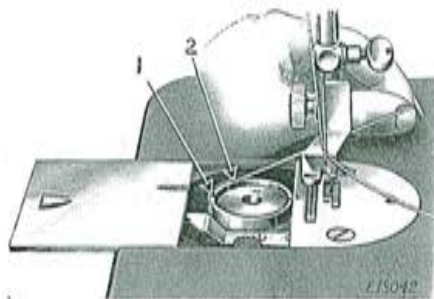

FIG. 8. BOBBIN CASE THREADED

When closing the slide, see that the thread is in the slot (3, Fig. 9) in the right edge of the slide, as shown below.

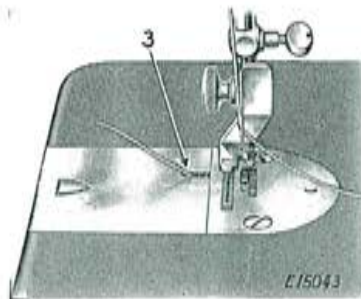

FIG. 9. UNDER THREADING COMPLETED

To Set the Needle

Turn the balance wheel over toward you until the needle bar moves up to its highest position, loosen the thumb screw (V, Fig. 3) in the needle clamp (Y, Fig. 3) and put the needle up into the clamp as far as it will go, with its flat side toward the right; then tighten the thumb screw. To select the correct Needle, see page 61.

Upper Threading

SEE FIG. 10 ON THE FOLLOWING PAGE

Turn the balance wheel over toward you until the thread take-up lever (5) is raised to its highest position. Place the spool of thread on the spool pin at the top of the machine, lead the thread into the thread guide (1) at the left, down, under and from right to left between the tension discs (2), into the small wire spring (3), under the thread regulator (4) at the left (**not through the eye in the thread regulator**), up and from right to left through the hole in the end of the thread take-up lever (5), down into the eyelet (6), into the lower wire guide (7), then from left to right through the eye of the Needle (8).

Draw about two inches of thread through the eye of the Needle with which to commence sewing.

Instructions for threading the machine for darning and for embroidery are given on pages 57 and 58.

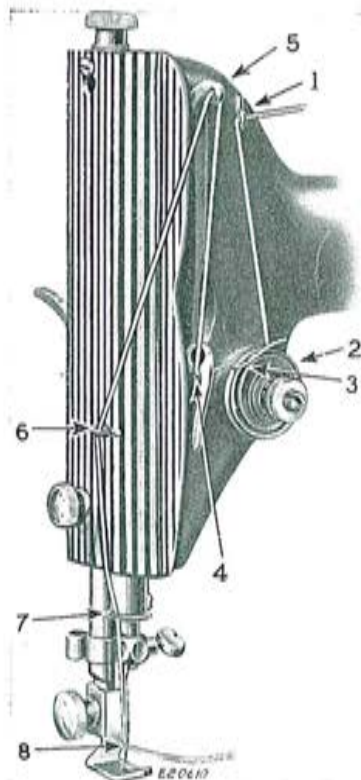

FIG. 10. UPPER THREADING

To Prepare for Sewing

With the left hand, hold the end of the needle thread, leaving it slack from the hand to the needle.

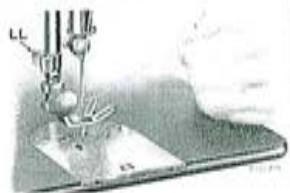

FIG. 11. DRAWING UP BOBBIN THREAD

Turn the balance wheel over toward you until the needle moves down and up again to its highest position, thus catching the bobbin thread. Draw up the needle thread and the bobbin thread will come up with it through the hole in the throat plate, as shown in Fig. 11. Lay both threads back

under the presser foot diagonally across the feed, as shown in Fig. 11A, to the right or left, depending upon which side of the needle the material is to be located, so that when the presser foot is lowered, the threads will be firmly held between the feed and the presser foot.

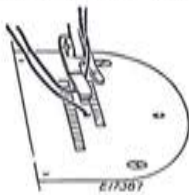

FIG. 11A. THREADS IN POSITION TO COMMENCE SEWING

To Commence Sewing

Place the material beneath the presser foot, lower the presser foot and commence to sew, pressing the knee controller to the right, or depressing the foot controller, to start the machine.

When sewing thick material, it may be necessary to turn the balance wheel over toward you by hand to start the machine. This should also be done if the machine stops when sewing across thick seams.

To Remove the Work

Let the thread take-up lever rest at its highest position, raise the presser foot and draw the fabric back and to the left about two inches; pass the threads over the thread cutter (LL, Fig. 11) and pull down lightly to sever them. Leave the ends of the threads under the presser foot.

Tensions

For ordinary stitching, the needle and bobbin threads should be locked in the center of the thickness of the material, thus:



FIG. 12. PERFECT STITCH

If the tension on the needle thread is too tight, or if that on the bobbin thread is too loose, the needle thread will lie straight along the upper surface of the material, thus:



FIG. 13. TIGHT NEEDLE THREAD TENSION

If the tension on the bobbin thread is too tight, or if that on the needle thread is too loose, the bobbin thread will lie straight along the under side of the material, thus:



FIG. 14. LOOSE NEEDLE THREAD TENSION

To Regulate the Tensions

The tension on the needle thread should be regulated only when the presser foot is down. Having lowered the presser foot, turn the small thumb nut (U, shown in Figs. 15 and 3), at the front of the tension discs, over to the right to increase the tension. To decrease the tension, turn this thumb nut over to the left.



FIG. 15. NEEDLE THREAD TENSION

The tension on the bobbin thread is regulated by the larger screw (A, Fig. 4) which is nearest the back of the bobbin case tension spring. To increase the tension, turn this screw over toward you. To decrease the tension, turn this screw over from you.

When the tension on the bobbin thread has been once properly adjusted, it is seldom necessary to change it, as a correct stitch can usually be obtained by varying the tension on the needle thread.

To Regulate Stitch Length

The machine is adjustable for stitches from 6 to 30 to the inch, as indicated by the numerals on the stitch indicator plate (A, Fig. 16).

Set the lever (B, Fig. 16) with its upper side in line with the numeral representing the desired number of stitches to the inch.

For Back Tacking, raise the lever (B) to the upper end of the indicator plate (A) marked "Back Tack." The machine will then stitch in a reverse direction, making it easy to fasten the ends of seams.

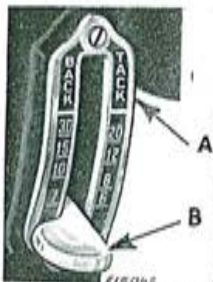

FIG. 16. STITCH REGULATOR

To Turn a Corner

Stop the machine when the needle is commencing its upward stroke. Raise the presser foot and turn the work as desired, using the needle as a pivot, then lower the presser foot.

To Regulate the Pressure on the Material

For ordinary family sewing, it is seldom necessary to change the pressure on the material. If sewing fine silk or flimsy material, lighten the pressure by turning the thumb screw (O, Fig. 5) on the top of the machine to the left so that it screws up. To increase the pressure, turn this thumb screw to the right, so that it screws down. The pressure should be only heavy enough to prevent the material from rising with the needle and to enable the feed to move the work along evenly. The heavier the material, the heavier the pressure; the lighter the material, the lighter the pressure.

Basting

The longest stitch made by the machine is found satisfactory for basting, after loosening the tension on the needle thread so that the stitches may be easily pulled from the material.

Machine basting is firmer and more even than that done by hand, in addition to being much quicker.

To Sew Flannel or Bias Seams

Use a short stitch and as light a tension as possible on the needle thread to leave the thread loose enough in the seam to allow the goods to stretch if necessary.

To Oil the Machine

To insure easy running, the machine requires oiling and if used continuously it should be oiled

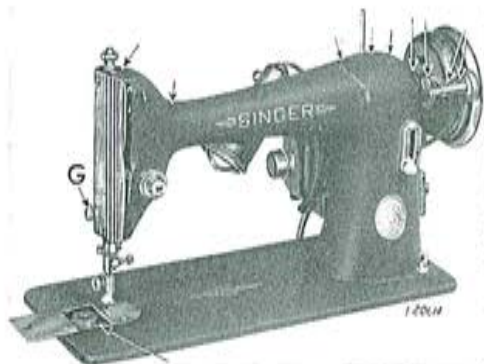

FIG. 17. FRONT VIEW, SHOWING OILING POINTS

each day. With moderate use, an occasional oiling is sufficient. Oil should be applied at each of the places shown by unlettered arrows in Figs 17 and 18. One drop of oil at each point is sufficient. Oil holes are provided in the machine for bearings which cannot be directly reached.

To oil the mechanism under the slide, draw the slide (see Fig. 17) to the left and after removing the lint and dust which may have accumulated (see instructions on pages 23 to 26, inclusive) put a few drops of oil on the small piece of felt at the right of the bobbin ejector. The slide should then be closed.

Take out the thumb screw (G, Fig. 17) near the lower end of the face plate, raise the plate and slip it off over the head of the screw near the upper end of the plate; put one drop of oil into each of the oil holes and joints.

At the back of the machine is a round plate or cover, fastened by a thumb screw; loosen the screw, turn the plate upward and fasten by tightening the screw; turn the balance wheel slowly and oil the moving parts inside, then turn the cover down and fasten it as before.

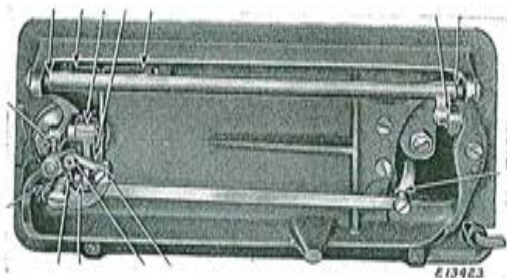

FIG. 18. OILING POINTS AT THE BASE OF MACHINE

To reach the parts underneath the bed of the machine, turn the machine back on its hinges and apply oil to the oil holes and bearings indicated by the arrows in Fig. 18.

To Lubricate the Motor

NEVER USE OIL ANYWHERE ON THE MOTOR. When the machine is shipped from the

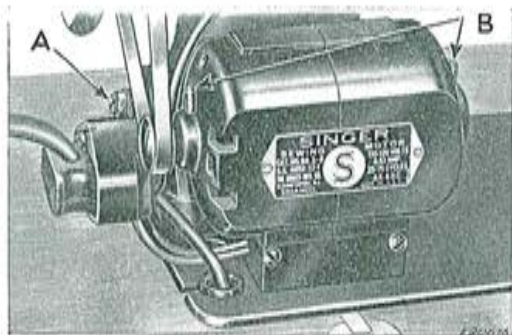

FIG. 19. MOTOR GREASE TUBES

factory, the two motor grease tubes (B, Fig. 19) are filled with sufficient SINGER MOTOR LUBRICANT for approximately six months use, under ordinary circumstances.

At least once every six months thereafter, these grease tubes should be refilled with the SINGER MOTOR LUBRICANT, furnished with the machine. To do this, insert the tip of the tube of lubricant into the hole at the top of each of the grease tubes and force the lubricant through each hole until both grease tubes are filled.

To Clean the Stitch Forming Mechanism

After considerable use, the stitch forming mechanism of the machine may become clogged with lint and this may interfere with the perfect operation of the machine.

Occasionally remove the bobbin case from the machine, as instructed below and on the following page, and remove any lint, etc., which has accumulated in the machine.

To Remove the Bobbin Case

(OPERATOR BEING AT THE FRONT OF THE MACHINE)

Raise the needle to its highest position by turning the balance wheel over toward you. Draw the slide plate (NN, Fig. 20) slightly to the left, then lift its right hand end and draw it toward the needle until it is disengaged from the spring in the bed of the machine.

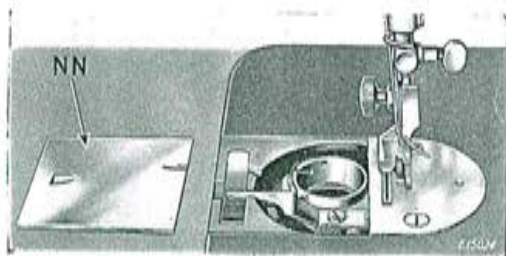

FIG. 20. SLIDE REMOVED

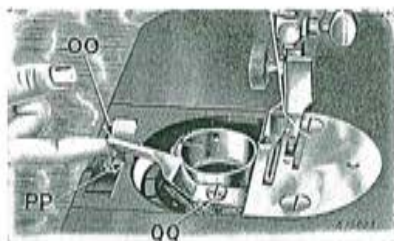

FIG. 21. RAISING THE LATCH

Insert the nail of the forefinger of the left hand under the latch (OO, Fig. 21), raise the latch just high enough to clear the edge at (PP, Fig. 21) and then move it toward you.

Under no circumstances must the screw (QQ, Fig. 21) be loosened. The loosening of this screw will change the clearance for the thread between the bobbin case and the bobbin case position bracket.

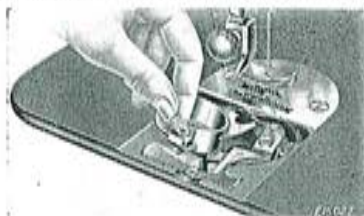

FIG. 22. REMOVING THE BOBBIN CASE

Hold the bobbin case between the forefinger and the thumb of the left hand as shown in Fig. 22. Tilt the bobbin case to the left and at the same time slightly turn the right or forked end toward you so that it is moved out of engagement with the sewing hook. Then tilt the bobbin case toward the right and remove it (see Fig. 22).

To Replace the Bobbin Case

(OPERATOR BEING AT THE FRONT OF THE MACHINE)

See that the needle is raised to its highest position and that the latch (OO, Fig. 23) is raised from the slot (PP, Fig. 23) and moved toward you.

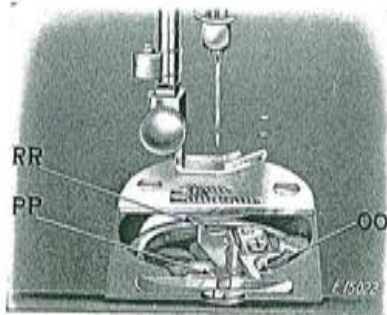

FIG. 23. SHOWING THE BOBBIN CASE POSITION BRACKET

Hold the Bobbin Case between the forefinger and thumb of the left hand as shown in Fig. 22. Insert the forked end of the Bobbin Case under the throat plate so that the fork straddles the end of the bobbin case position bracket (RR, Fig. 23). Then with a slight twisting motion of the Bobbin Case to the left and to the back, lightly press it downward until the edge of the sewing hook engages in the groove under the rim of the Bobbin Case.

Having set the Bobbin Case into the correct position, lock the latch (OO, Fig. 23) in the notch (PP, Fig. 23) to hold the Bobbin Case in place.

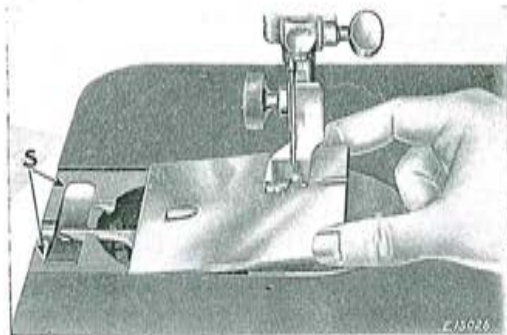

FIG. 24. REPLACING THE SLIDE

Then replace the slide from the right, as shown in Fig. 24, being careful to see that the two ends of the spring (S, Fig. 24) enter the grooves on the underside of the slide.

SINGER Needles should be used
in **SINGER** Machines.
These Needles and their Containers
are marked with the
Company's Trade Mark "SIMANCO."*1

Needles in Containers marked
"FOR SINGER MACHINES"
are NOT **SINGER** made needles. 2

HINTS

Belt. See that the belt has the correct tension. This tension should be only enough to keep the belt from slipping. If the belt tension is incorrect, loosen the screw (A, Fig. 19) about one turn and allow the motor to drop downward until the belt has the correct tension, then tighten the screw.

Machine Working Heavily. If the machine runs hard after standing idle for some time, use a little kerosene in the oiling places, run the machine rapidly, then wipe clean and oil.

To Avoid Breaking Needles. See that the presser foot or attachments are securely fastened by the thumb screw. Do not sew heavy seams or very thick goods with too fine a needle. A large needle and thread to correspond should be used on heavy work (see page 61).

See that the needle is not bent, and avoid pulling the material when stitching.

Breaking of Needle Thread. If the needle thread breaks, it may be caused by:

Improper threading.

Tension being too tight.

The thread being too coarse for size of needle.

The needle being bent, having a blunt point,
or needle set incorrectly.

Thread take-up spring bent.

Breaking of Bobbin Thread. If the bobbin thread breaks, it may be caused by:

Improper threading of bobbin case.

Tension being too tight.

Skipping of Stitches. The needle may not be accurately set into the needle bar or the needle may be blunt or bent. The needle may be too small for the thread in use. Thread take-up spring may be bent or incorrectly adjusted.

Free Instruction for using the machine is gladly given at any **SINGER** Shop.

INSTRUCTIONS FOR USING THE ATTACHMENTS

THE FOOT HEMMER



FIG. 25. THE FOOT
HEMMER

The Foot Hemmer (Fig. 25) is attached to the machine in place of the presser foot. Raise the needle to its highest position, loosen the thumb screw which clamps the presser foot to the presser bar and remove the presser foot. Attach the Foot Hemmer to the bar, taking care to tighten the screw firmly so that the Hemmer will not become loose when the machine is running. Turn the balance

wheel slowly to make sure that the needle goes through the center of the needle hole and that the lower thread is properly pulled up.

How to Start the Hem at the Very Edge

How to start the hem at the very edge of the material is of great importance in learning to use the Hemmer. If the hem is not started at the edge and the material is pulled bias a perfect hem cannot be made.

There are several ways of starting the hem at the edge, but the most practical one is as follows:

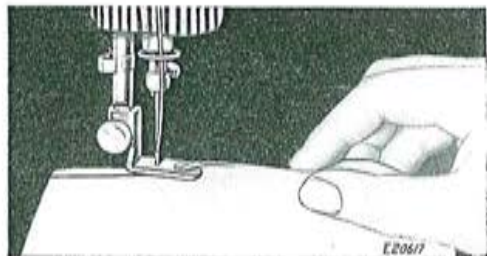

FIG. 26. STARTING A HEM AT THE EDGE

1. Fold over about $\frac{1}{8}$ " of the edge of the material at the starting point for a distance of about one inch.
2. Place the material in the Hemmer at an angle leading to the right at a point just beyond the fold.
3. Draw the material toward you through the Hemmer, as shown in Fig. 26, at the same time making the second fold at the very edge. Continue to draw the material through the Hemmer until the edge is just under the needle. Place the upper and lower threads together under the Hemmer foot and assist in starting of the hem by slightly pulling the threads from the back as the machine is run.

Making a Hem with the Foot Hemmer

The same width of material must be kept in the Hemmer at all times. After placing the correct

width of the material in the Hemmer, hold it in a straight line and you will find it quite easy to make a perfect hem. See Fig. 27.

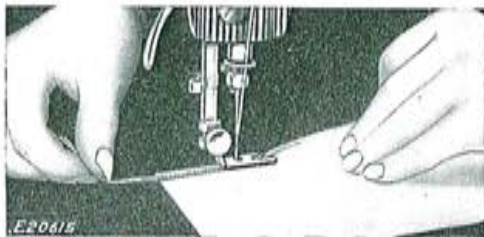

FIG. 27. MAKING A HEM WITH THE FOOT HEMMER

Making a Hemmed Seam with the Foot Hemmer

The hemmed seam is very practical to use on underwear, or in fact on any garment where a

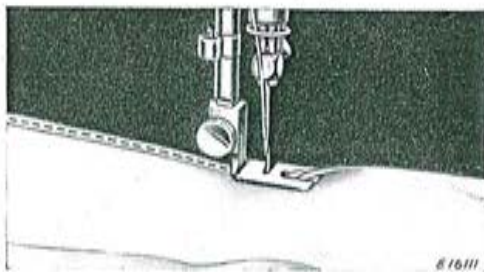

FIG. 28. MAKING A HEMMED SEAM

straight seam is used and where a small double seam would be suitable.

When using this seam the garment must first be fitted and the edge of the material trimmed, allowing for about one-eighth inch seam. The two edges are placed together and inserted in the Hemmer in the same manner as a single hem. If the material is bulky, the edge of the upper piece of material may be placed about one-eighth inch in from the edge of the lower piece. See Fig. 28.

The free edge of a hemmed seam may be stitched flat to the garment if desired. First open the work out flat, then place the hem in the scroll of the Hemmer, which acts as a guide, holding the edge of the hem in position while it is being stitched.

If the seam is stitched flat to the garment one row of stitching is visible on the right side.

The hemmed seam may be used on muslin, lawn, percale, organdie or other fine materials where a narrow seam is desirable.

SINGER Needles should be used
in **SINGER** Machines.
These Needles and their Containers
are marked with the
Company's Trade Mark "SIMANCO."*1

Needles in Containers marked
"FOR SINGER MACHINES"
are NOT **SINGER** made needles. 2

Hemming and Sewing on Lace in One Operation

Start the hem in the regular way, and with the needle holding the hem in position raise the presser

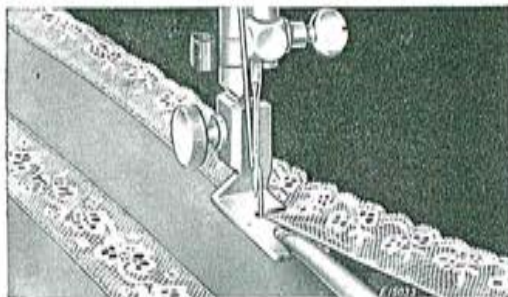

FIG. 29. HEMMING AND SEWING ON LACE

bar sufficiently to allow the edge of the lace to be slipped in under the Foot Hemmer, at the same time bringing it up through the slot at the right of the Hemmer. See Fig. 29. Lower the bar, turn the balance wheel and catch the edge of the lace with the needle. Guide the hem with the right hand and the lace with the left. Care should be taken not to stretch the lace as it is being fed into the Hemmer.

It is not practical to sew gathered lace on with the Foot Hemmer, as the fulled lace catches in the Hemmer slot.

A very attractive way of applying lace so that the stitching of the hem is not visible is to start the hem in the regular way, slipping the lace in from the left until the edge is caught with the hem in the same position as the upper piece of material when making a hemmed seam.

ADJUSTABLE HEMMER—Hemming

Remove the presser foot and attach the adjustable Hemmer in its place, as shown in Fig. 30. This

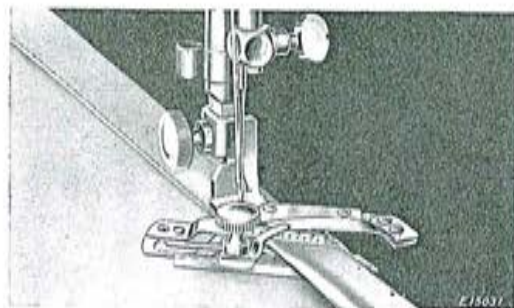

FIG. 30

Hemmer will turn hems from $\frac{3}{16}$ " to $\frac{1}{8}$ " wide. The adjustment is made by loosening the thumb screw on the Hemmer and moving the scale to the right or left until the hem turned is of the desired width. Place the cloth under the Hemmer and draw the edge toward the left under the scale, as shown in Fig. 30. Draw the edge of the cloth back and forth until the fold of the hem is formed, stopping with the end under the needle. Lower the presser bar and commence to sew, being careful to so guide the cloth as to keep the Hemmer full.

ADJUSTABLE HEMMER—Wide Hemming

To make a hem more than $\frac{1}{8}$ " wide, loosen the thumb screw in the Hemmer and move the scale

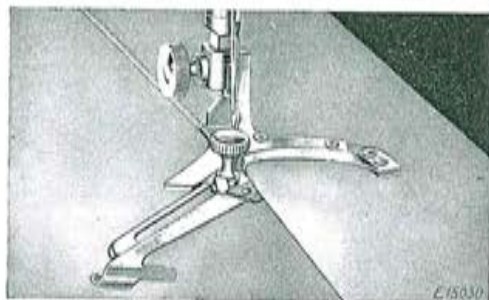

FIG. 31

to the right as far as it will go, then swing it toward you as shown in Fig. 31 and tighten the thumb screw. Fold and crease down a hem of the desired width; pass the fold under the extension at the right of the Hemmer, and the edge into the Folder as shown in Fig. 31, and proceed to stitch the hem.

MULTIPLE SLOTTED BINDER

This multiple slotted Binder will apply **unfolded bias binding** $\frac{1}{8}$ inch in width and commercial **folded binding** in sizes 1, 2, 3, 4 and 5 to the seams or to the edges of garments. These sizes of folded binding are $\frac{1}{4}$, $\frac{1}{8}$, $\frac{3}{8}$, $\frac{1}{2}$ and $\frac{5}{8}$ inch in width, respectively, and are fed through slots of corresponding sizes in the binder scroll. (See Fig. 32). Binding may be purchased in a variety of materials and colors.

For convenience in determining the correct width of **unfolded binding** ($\frac{1}{8}$ inch), this measurement is marked on the Binder, as shown in Fig. 32.

The two upright guide pins shown in Fig. 32 eliminate manual guiding of the binding.

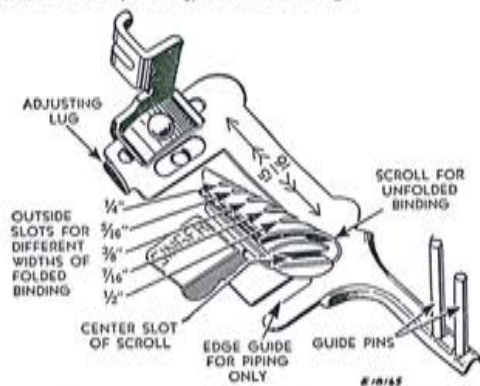

FIG. 32. MULTIPLE SLOTTED BINDER 160350

The wide range of bindings that can be applied with this Binder makes it useful for a large variety of work. It will be found particularly advantageous for making children's wear, lingerie, summer dresses, and other dainty articles which call for the narrower bindings.

As two different widths of binding of contrasting colors can be fed through the Binder at the same time, attractive binding and piping effects can be produced in one operation.

To Attach the Binder

Raise the needle to its highest position, then attach the Binder to the presser bar in place of the presser foot.

See that the needle enters the center of the needle hole.

To Insert the Binding in the Binder

Cut all binding to a long point to the left, as shown in Fig. 33.

Folded Bias Binding must be inserted in the slot or slots of corresponding sizes. (See Fig. 36).

Unfolded or Raw Edge Bias Binding must be inserted in the open end of the scroll. (See Fig. 34).

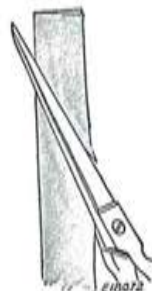

FIG. 33

After inserting the pointed end of the binding in the Binder, push it through until the full width of the binding is under the needle.

Guide the binding by means of the two upright pins, as shown in Figs. 34 and 36.

To Insert the Garment in the Binder

Place the edge to be bound as far to the right as it will go in the center slot of the scroll, as shown in Fig. 34, and draw it back under the binder foot.

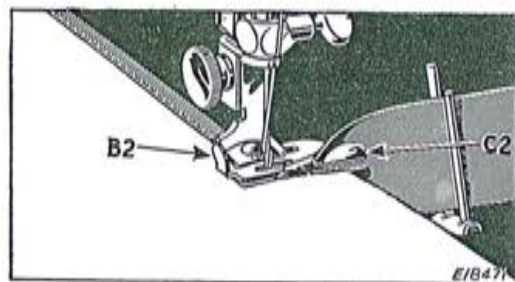

FIG. 34. BINDING WITH UNFOLDED BINDING

Lower the Binder by means of the presser foot lifter, and commence to sew. Keep the material well within the center slot of the scroll so that the edge will be caught in the binding.

To Adjust the Binder

To bring the inner edge of the binding closer to the stitching, move the scroll (C2, Fig. 34) to the right by means of the lug (B2, Fig. 34). This is the usual adjustment when binding straight edges.

When binding curves, move the scroll to the left to bring the inner edge of the binding farther from the stitching and allow for the sweep of the curve.

Piped Edge

To produce a **piped edge** on garments, move the lug (B2, Fig. 35) to the left to bring the stitching about midway of the folded binding.

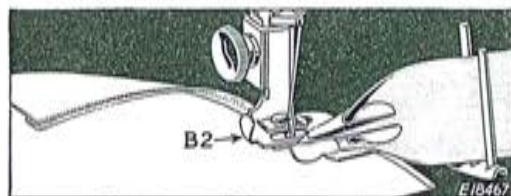

FIG. 35
POSITION OF GARMENT AND BINDING WHEN PIPING EDGES

Crease the raw edges of the garment toward the wrong side about $\frac{1}{8}$ inch, and insert the folded edge, raw edges uppermost, into the edge guide on the Binder and **beneath** the binding.

When stitched, both sides of the garment will be finished, and the right side will show the piped edge.

Piping and Binding in One Operation

A garment can be piped and bound in one operation, as shown in Fig. 36.

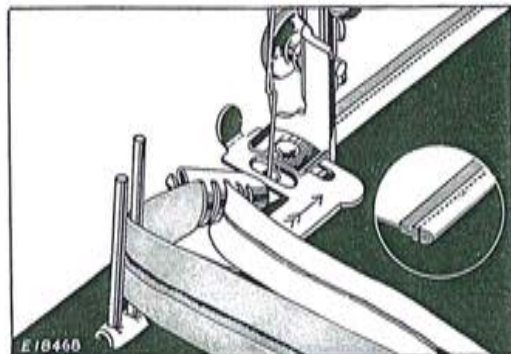

FIG. 36. PIPING AND BINDING IN ONE OPERATION

IMPORTANT: When piping and binding at the same time, as shown above, insert the **narrow width** of binding **first** in its slot, then insert the **wider width** in its slot. **Two consecutive widths should not be used at the same time.** That is, if No. 1 is used, the wider binding should not be smaller than No. 3. If No. 2 is used, the wider binding should be not less than No. 4. **Never use Nos. 1 and 2, or 2 and 3, etc., together.**

Use the upright guide pins to guide the wider of the two widths of binding, as shown in Fig. 36.

To Bind Outside Curves

Allow the edge to be bound to pass freely through the scroll without crowding against the scroll wall. The material must be guided from the back of the Binder and to the left, permitting unfinished edges to swing naturally into the scroll of the Binder.

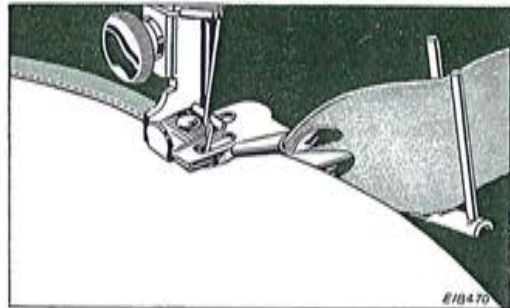

FIG. 37. BINDING AN OUTSIDE CURVE

Never pull the binding while it is being fed through the Binder, as this may stretch the binding, making it too narrow to stitch or to turn in the edges.

When binding curves, turn the material only as fast as the machine sews.

Do not push the material in too fast as this will pucker the edge.

Do not stretch the material as this will distort the edge so that the curve will not have the proper shape when finished.

If the stitching does not catch the edge of the binding, adjust the scroll slightly to the left.

To Bind Inside Curves

When binding an inside curve, straighten out the edge of the material while feeding it into the Binder, being careful not to stretch the material.

Soft materials like batiste or crepe de chine require a row of stitching added close to the edge of the curve before binding.

To Apply French Folds to Curves

Place the material under the Binder and stitch the binding onto the face of the material, as shown in Fig. 38.

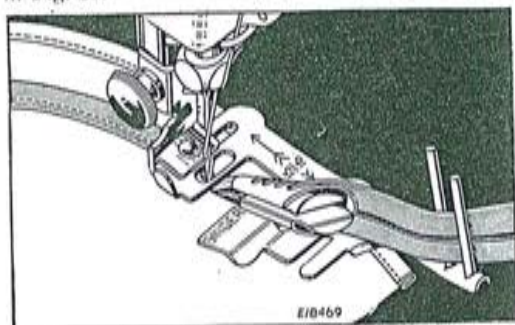

FIG. 38. APPLYING A FRENCH FOLD

For guidance in applying the rows of French folds, mark the material with a line of basting stitches or with chalk or pencil.

THE EDGE-STITCHER

This useful attachment is fastened to the machine in place of the presser foot, and will be found an indispensable aid whenever stitching must be kept accurately on the extreme edge of a piece of material. The slots, numbered from 1 to 5 in Fig. 39, serve as guides for sewing together laces, insertions and embroideries, sewing in position hems or folded edges, piping or sewing flat braid to a garment.

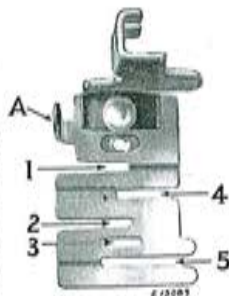

FIG. 39
THE EDGE-STITCHER

Adjusting the Edge-Stitcher

After attaching the Edge-Stitcher to the machine, turn the balance wheel slowly by hand to see that the needle goes through the center of the needle hole. The distance of the line of stitching from the edge of the material in the slots can be regulated by pushing the lug (A, Fig. 39) to the right or left. If it moves hard, put a drop of oil under the blue spring, then wipe it dry.

Sewing Lace Together with the Edge-Stitcher

It is difficult to sew two lace edges together even after basting, but the Edge-Stitcher makes it pos-



FIG. 40. SEWING LACE TOGETHER

sible to stitch on the very edge. Place one edge in slot 1 and the other in slot 4, and adjust lug (A, Fig. 39) until both edges are caught by the stitching. Hold the two pieces slightly overlapped to keep them against the ends of the slots. The thread tensions should be loose to avoid puckering of fine lace.

Lace and ribbon or other insertions can be set in by using the same slots (1 and 4, Fig. 39). The

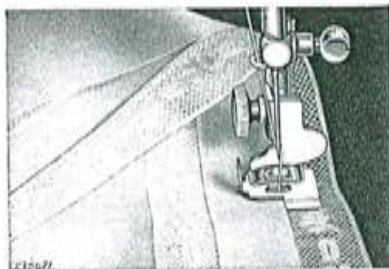

FIG. 41. SETTING IN LACE INSERTION

material may be folded over before placing it in the slot so that a double thickness is stitched and will not pull out. The surplus material is trimmed away close to the stitching as shown in Fig. 41.

Piping with the Edge-Stitcher

Piping is very attractive if the correct contrasting color is chosen for the piping material. Place the piping, with its finished edge to the left, in slot 3 (Fig. 39). Place the edge to be piped in slot 4, as shown in Fig. 42.

Piping should preferably be cut bias, and should be cut twice the width of the slot (3, Fig. 39) in the Edge-Stitcher so that it can be folded once.

Applying Bias Folds With the Edge-Stitcher

Folded bias tape or military braid, used for neat and colorful trimming, may be sewn on by placing the garment under the Edge-Stitcher the same as under a presser foot, and placing the tape in slot 1 or 4 (Fig. 39). To make a square corner, sew until the turning point is reached, then remove the tape

from the attachment and form the corner by hand, replace it in the slot and continue stitching, as

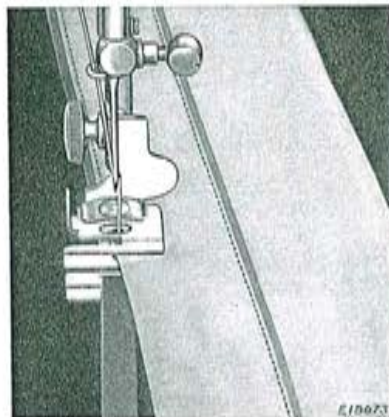

FIG. 42. PIPING WITH THE EDGE-STITCHER

shown in Fig. 43. To space two or more parallel rows, a guide line such as a crease, chalk mark or basting thread should be used.

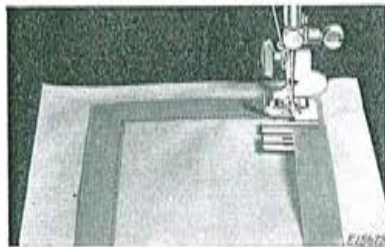

FIG. 43. APPLYING BIAS FOLDS WITH THE EDGE-STITCHER

Stitching a Wide Hem with the Edge-Stitcher

A wide hem on sheets, pillow slips, etc., may be stitched evenly with the Edge-Stitcher after the hem

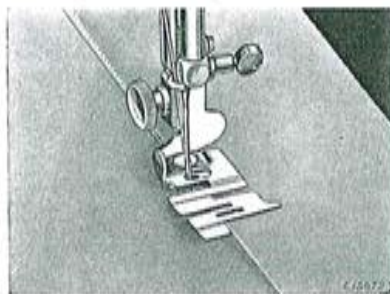

FIG. 44. MAKING A WIDE HEM

has been measured and the edge turned. Insert the edge in slot 5 as shown in Fig. 44 and adjust to stitch as close to the edge as desired.

Making a French Seam

An even French seam may be made by inserting the two edges to be joined, wrong sides together, in slot 1 or 2 and stitching close to the edge; then folding both right sides together and inserting the back of the seam into slot 1 again and stitching with just enough margin to conceal the raw edges. See Fig. 45.



FIG. 45. A FRENCH SEAM

Tucking with the Edge-Stitcher

Dainty narrow tucking may be produced on the Edge-Stitcher by inserting creased folds in slot 1 as

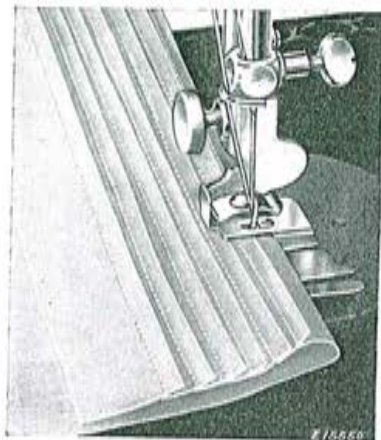

FIG. 46. TUCKING WITH THE EDGE-STITCHER

shown in Fig. 46, and adjusting the Edge-Stitcher to right or left for the desired width of tuck, up to $\frac{1}{8}$ inch. Successive tucks may be easily creased by folding the material at the desired distance from the previous tuck, and then running the length of the fold over a straight edge such as the edge of the sewing machine cabinet. The secret of good tucking lies in a light tension, short stitch, and fine thread and needle.

SHIRRING WITH THE GATHERER

The Gatherer is fastened to the machine in the same manner as the presser foot. Material placed under the Gatherer and stitched in the usual way will be slightly gathered. Any fabric that drapes well is especially suited for shirring with the Gatherer. Most shirring with the Gatherer is done with a long stitch and tight tension. To increase the fullness of the gathers, lengthen the stitch. To decrease the fullness, shorten the stitch.

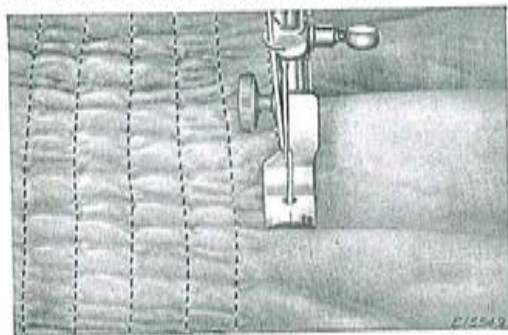

FIG. 47. THE GATHERER IN OPERATION

With the Gatherer, it is possible to shirr in narrow rows as shown in Fig. 47. The material may be guided as easily as when sewing with the presser foot. Fine materials, such as batiste, silk or net, may be very attractively shirred. Where only a slight fullness is required, as at the top of a sleeve or around the neck, the gatherer will be found very convenient.



FIG. 48. SHIRRING

A very pleasing effect may be gained by using thread or embroidery silk of contrasting color on the bobbin. Fig. 49 shows a white organdie collar and cuff set with red and green smocking made with the Gatherer, using fine crochet cotton or tating thread on the top and white cotton on the bobbin.

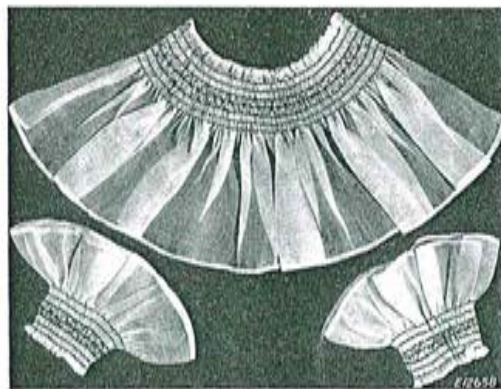

FIG. 49. SMOKING

RUFFLER

Lines 1, 2, 3, 4 and 5 shown in Fig. 50 indicate where the material is to be placed for various operations as follows:

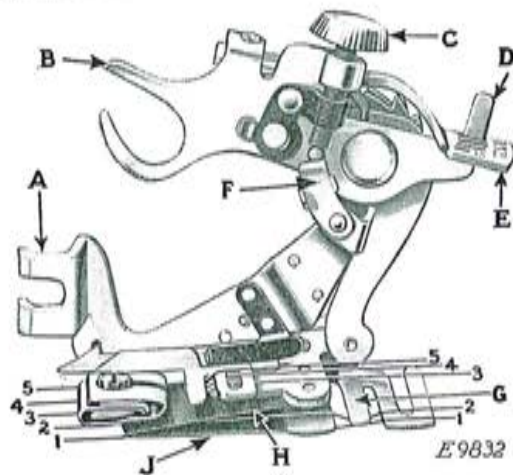

FIG. 50. THE RUFFLER AND ITS PARTS

- Line 1**—the correct position for the material to which the ruffled material is applied.
Line 2—material to be ruffled.
Line 3—the facing for the ruffle.
Line 4—the strip of piping material.
Line 5—the edge to be piped.

Refer to Fig. 50 when inserting the material in the Ruffler.

The names and uses of the principal parts of the Ruffler are as follows:

(SEE REFERENCES IN FIG. 50)

- A—FOOT**—The part by which the Ruffler is attached to the presser bar.
B—FORK ARM—the section that must be placed astride the needle clamp.
C—ADJUSTING SCREW—the screw that regulates the fullness of the gather.
D—PROJECTION—the part that projects through the slots in the adjusting lever.
E—ADJUSTING LEVER—the lever that sets the Ruffler for gathering or for making a plait once at every six stitches, or once at every twelve stitches, as desired; also for disengaging the Ruffler, when either plaiting or gathering is not desired.
F—ADJUSTING FINGER—the part which regulates the width or size of the plaits.
G—SEPARATOR GUIDE—the guide on the underside of the Ruffler, containing slots into which the edge of the material is placed to keep the heading of the ruffle even; also for separating the material to be ruffled from the material to which the ruffle is to be attached.
H—RUFFLING BLADE—the upper blue steel blade with the teeth at the end to push the material in plaits up to the needle.
J—SEPARATOR BLADE—the lower blue steel blade without teeth, which prevents the teeth of the ruffling blade coming into contact with the feed of the machine, or the material to which ruffle or plaiting is to be applied.

To Attach the Ruffler to the Machine

Raise the needle bar to its highest position and remove the presser foot. Attach the ruffler foot (A, Fig. 50) to the presser bar by means of the thumb screw, at the same time placing the fork arm (B, Fig. 50) astride the needle clamp as shown in Fig. 51.

To Adjust the Ruffler for Gathering

The adjusting finger (F, Fig. 51) is not intended for gathering and should be moved forward or away from the needle, as shown in Fig. 51.

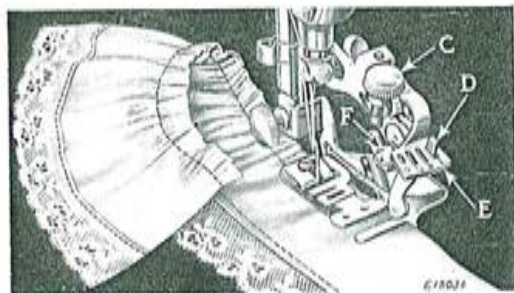

FIG. 51

Raise the adjusting lever (E, Fig. 51) and move it to the left so that the projection (D, Fig. 51) will enter the slot marked "1" in the adjusting lever (E) when the lever is released. The ruffling blade will then move forward and back once at every stitch. Insert the material to be ruffled between the two blue blades, following the line 2 in Fig. 50. Draw the material slightly back of the needle, lower the presser bar and commence to sew.

To make fine gathering, shorten the stroke of the ruffling blade by turning the adjusting screw (C, Fig. 51) upward; also shorten the stitch. To make full gathering, lengthen the stroke of the ruffling blade by turning the adjusting screw (C) downward; also lengthen the stitch. By varying these adjustments, many pleasing varieties of work can be accomplished.

To Make a Ruffle and Sew it to a Garment in One Operation

Insert the material to be ruffled between the two blue blades, as shown in Fig. 52, following the line

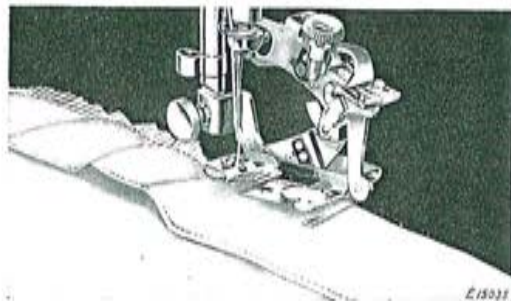

FIG. 52

2, in Fig. 50. Place the garment to which the ruffle is to be attached, under the separator blade, following the line 1, in Fig. 50. Proceed the same as for gathering.

The edge of the ruffled seam can be bound by using the Binder.

To Ruffle and Sew on a Facing in One Operation

Insert the material to be ruffled between the two blue blades, following the line 2, in Fig. 50. Place the garment to which the ruffle is to be attached, under the separator blade, following the line 1, in Fig. 50. Place the material in the facing over the upper blue blade, as shown in Fig. 53, following the line 3, in Fig. 50. The facing may be straight or bias material. If the facing is to be on the right side of the garment, place the garment and the

ruffle so that the wrong sides are together. If the facing is to be on the wrong side, place the right sides of the garment and the ruffle together.

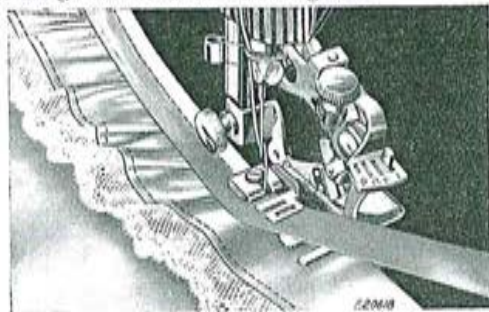

FIG. 53

Piping a Ruffle

Insert the material to be ruffled between the two blue blades, following the line 2, in Fig. 50. This

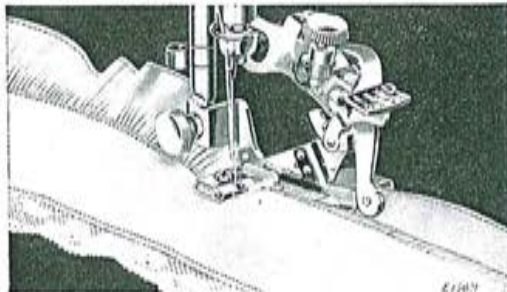

FIG. 54

material must not be over $1\frac{1}{4}$ inches wide, as it is carried through the Ruffler with the finished

edge of the ruffle to the right of the attachment as shown in Fig. 54.

The material for piping must measure about $\frac{1}{4}$ inch wide when folded in the center and is usually cut on the bias. Place the piping material in the Ruffler, following the line 4, in Fig. 50, with the folded edge of the piping to the right. The material to which the piping and ruffling are to be sewn should be folded on the edge and inserted in the Ruffler, following the line 5, in Fig. 50.

To Adjust the Ruffler for Plaiting

Raise the adjusting lever (E, Fig. 55) and move it to the right so that the projection (D, Fig. 55)

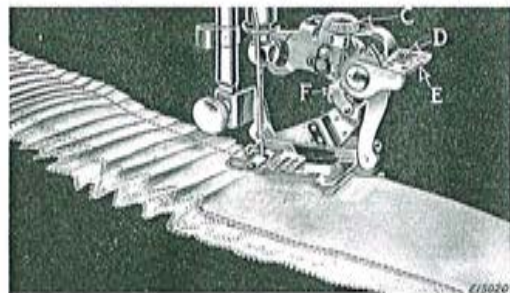

FIG. 55

will enter the slot marked "6" in the adjusting lever when the lever is released. The ruffling blade will then move forward and back once at every six stitches. To adjust the ruffling blade to make a plait once at every twelve stitches, place the adjusting lever (E, Fig. 55) so that the projection (D) enters the slot marked "12" in the adjusting lever. Insert the material to be plaited between the two blue blades, following the line (2, Fig. 50). The size or width of plaits is regulated by the adjusting screw

(C, Fig. 55) and the adjusting finger (F, Fig. 55). To make a wider plait, move the adjusting finger (F) back or toward the needle and turn the adjusting screw (C) downward. To make a smaller plait, turn the adjusting screw (C) upward. The distance between plaits is regulated by the length of stitch.

To Adjust the Ruffler for Group Plaiting and Gathering

The Ruffler can be adjusted for group plaiting by lifting the adjusting lever (E, Fig. 56) and moving

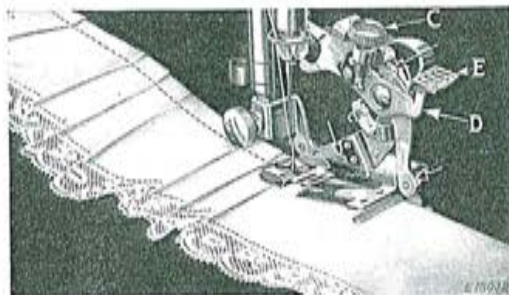

Fig. 56

it to the right so that the top of the projection (D, Fig. 56) enters the small slot indicated by the star on the adjusting lever. This should be done at the points where you wish to make the space between the plaits. The Ruffler will then stop and plain stitching will be made. When the desired space has been made, adjust the lever (E) so that the projection (D) enters either the slot marked "6" or the slot marked "12." By alternately making groups of plaits and plain spaces, as shown in Fig. 56, very attractive work can be produced.

To Oil the Ruffler

Occasionally apply a drop of oil to the working parts of the Ruffler at each of the places indicated by the unlettered arrows in Fig. 56. After oiling, operate the Ruffler on a waste piece of material to prevent the oil soiling the work. If the Ruffler does not plait evenly, a drop of oil may remedy the trouble.

EMBROIDERY AND DARNING

While embroidery and darning can be done on the machine when threaded for regular sewing, the use of feed cover plate (W, Fig. 57) No. 32622 is recommended, as movable contact with the feed in some cases might interfere with the handling of the work.

Do not change the adjustment of the feed dog in any way, as it is essential that its position should remain as originally fixed.

When the feed cover plate (W, Fig. 57) is used, it is necessary to lead the needle thread through the eye in the thread regulator (V, Fig. 57) at the left of the tension discs and *not under the thread regulator*. With this exception, the threading is the same as for regular sewing (see Fig. 10, page 15).

Remove the presser foot and let down the presser bar lifter to restore the tension on the needle thread, which is released and inoperative when the lifter is raised.

To attach the feed cover plate, draw to the left the slide that covers the bobbin case and insert the downwardly projecting hooks on the cover plate under the edge of the throat plate and push to the right. After bringing the hole at the right of the cover plate in line with the hole in the throat plate, press the cover into position, and close the slide (see Fig. 57).

Feed cover plates are not included in the regular sets of attachments; they are on sale at all SINGER Shops.

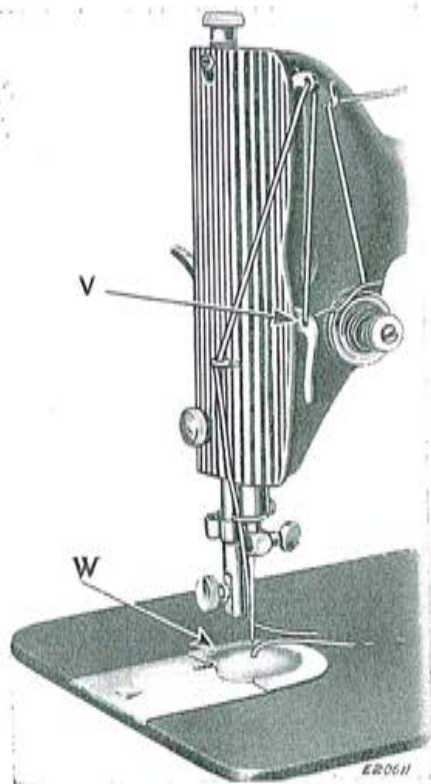
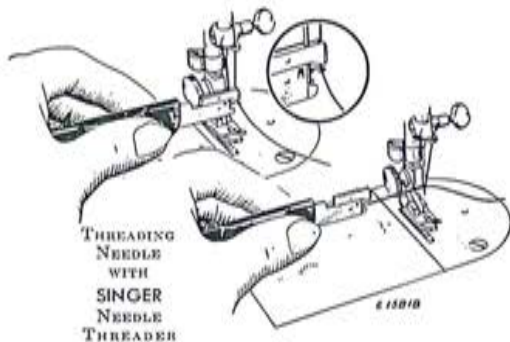

FIG. 57. MACHINE THREADED FOR EMBROIDERY AND DARNING

The **SINGER** Universal Threader and
Seam Ripper
Makes Threading Easy



This useful little accessory enables you to thread a hand sewing needle or a machine needle without eye-strain. As shown on the following page, it also serves



as a seam ripper with a blade set at just the right angle for quickly picking out stitches. Both ends fold into the handle like a jack-knife. It is sold by all **SINGER** Shops at a reasonable price.

The SINGER Material Gripper

Taking out stitches is no longer a tedious job when you use the SINGER Seam Ripper and

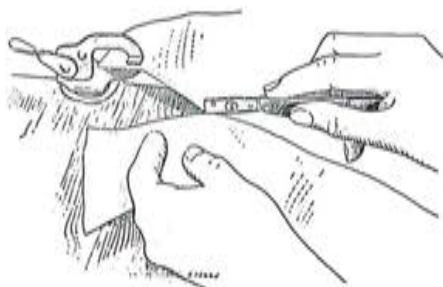

OPENING SEAM WITH
SINGER SEAM RIPPER
WHILE MATERIAL GRIPPER HOLDS CLOTH

Material Gripper, as shown above. The Gripper acts as a third hand, holding your material while you pin, sew or rip. It is sold by all SINGER Shops at a reasonable price.

RELATIVE SIZES OF NEEDLES AND THREAD

(Class and Variety of Needles Used, 15x1)

SIZES OF NEEDLES	CLASSES OF WORK	SIZES OF COTTON, SILK OR LINEN THREAD
9	Georgette, chiffon, net, light weight synthetic fabrics, fine dimity, lawn, batiste, and other featherweight or sheer fabrics. For infants' clothes and for dainty lingerie; also fine lace and all delicate or gossamer fabrics.	100 to 150 Cotton OO & OOO Silk Twist
11	All medium, light weight summertime fabrics. For children's clothes, dainty washable dresses and aprons, glass curtains.	80 to 100 Cotton O Silk Twist 56-3 Nylon
14	Light weight woolens, firm dress silks and cottons, draperies and fabric furnishings. For smocks and men's fine shirts. For general household sewing; for fine quilting.	60 to 80 Cotton A & B Silk Twist
16	Heavy cretonne, madras, muslin, damasks and quilts. For stitching aprons and men's work shirts.	40 to 60 Cotton C Silk Twist
18	Heavy weaves of coating, canvas, bed ticking, awnings, porch furniture covers, boys' duck suits, work or sports uniforms.	30 to 40 Cotton D Silk Twist
19	Suiting, ticking, sackings, tarpaulin, duck, drilling. For wash uniforms and bedding supplies for hospitals and hotels.	24 to 30 Cotton E Silk Twist 60 to 80 Linen
21	Bags, Coarse Cloths and Heavy Goods.	40 to 60 Linen or very Coarse Cotton

When sending orders for needles be sure to specify the size required.

You will obtain the best stitching results from your sewing machine if it is fitted with a SINGER Needle.

THE IMPORTANCE OF USING
SINGER* NEEDLES FOR YOUR
SEWING MACHINE

You will obtain the best stitching results from your sewing machine if it is fitted with a **SINGER** Needle.

SINGER Needles can be purchased from any **SINGER** Shop or **SINGER** Salesman.

SINGER Needles are contained in the **SINGER** Green Needle Packet with the famous red letter "S" upon it.