



**Zig-Zag Sewing Machine,  
Free-Arm Model 7105**

**SINGER\***



## CONTENTS

	Page
<b>Chapter 1. Getting to Know Your Machine</b> . . . . .	2
Principal Parts . . . . .	2
Accessories . . . . .	3
<b>Chapter 2. Getting Ready to Sew</b> . . . . .	4
Choosing and Changing Accessories . . . . .	4
Fabric Weight Table . . . . .	6
Fabric Thread and Needle Table . . . . .	8
Needle-Fabric Combinations . . . . .	10
Operating the Machine . . . . .	10
The Bobbin Thread . . . . .	11
Winding the Bobbin • Threading the Bobbin Case	
Threading the Machine . . . . .	13
Raising the Bobbin Thread	
<b>Chapter 3. Straight Stitching</b> . . . . .	15
Adjusting Machine Stitch to Suit Your Fabric . . . . .	15
Setting Selectors • Regulating Presser Foot Pressure •	
Adjusting Stitch Length • Needle-Thread Tension	
Sewing a Seam . . . . .	17
Keeping the Seam Straight	
Applications . . . . .	18
Zipper Insertion • Darning	
<b>Chapter 4. Basic Zig-Zag Stitching</b> . . . . .	19
Adjusting Machine to Suit Your Fabric . . . . .	19
How to Set Selectors • Pattern Group Selector •	
Needle Position Selector • Stitch Width Selector • Adjusting Needle Tension •	
Adjusting Stitch Length • Adjusting Presser Foot Pressure	
Satin Stitching . . . . .	21
Applications . . . . .	22
Appliqué • Lingerie Seams • Zig-Zag Seam Finishes	
<b>Chapter 5. Machine Stitch Patterns</b> . . . . .	24
Setting Selectors . . . . .	24
Selecting a Pattern Group • Adjusting Width of the Design • Adjusting Stitch	
Placement • Adjusting Stitch Length • Adjusting Stitch Balance	
Adjusting Stitches to Suit Stretch Fabrics . . . . .	27
Guiding and Supporting Fabric • Adjusting Pressure	
Stitch Pattern Chart . . . . .	28
Applications . . . . .	29
Blindstitch . . . . .	29
Hems	
Multi Stitch Zig-Zag . . . . .	30
Bar Tacks • Mending a Tear	
Honeycomb Stitch . . . . .	31
Attaching Elastic	
<b>Chapter 6. Buttonholes and Buttons</b> . . . . .	32
Four-Step Buttonholing . . . . .	32
Changing Stitch Density	
Buttons . . . . .	34
<b>Chapter 7. Twin-Needle Stitching</b> . . . . .	35
<b>Chapter 8. Free-Arm Sewing</b> . . . . .	36
<b>Chapter 9. Performance Checklist</b> . . . . .	37
<b>Chapter 10. Caring for Your Machine</b> . . . . .	38
<b>Index</b> . . . . .	40

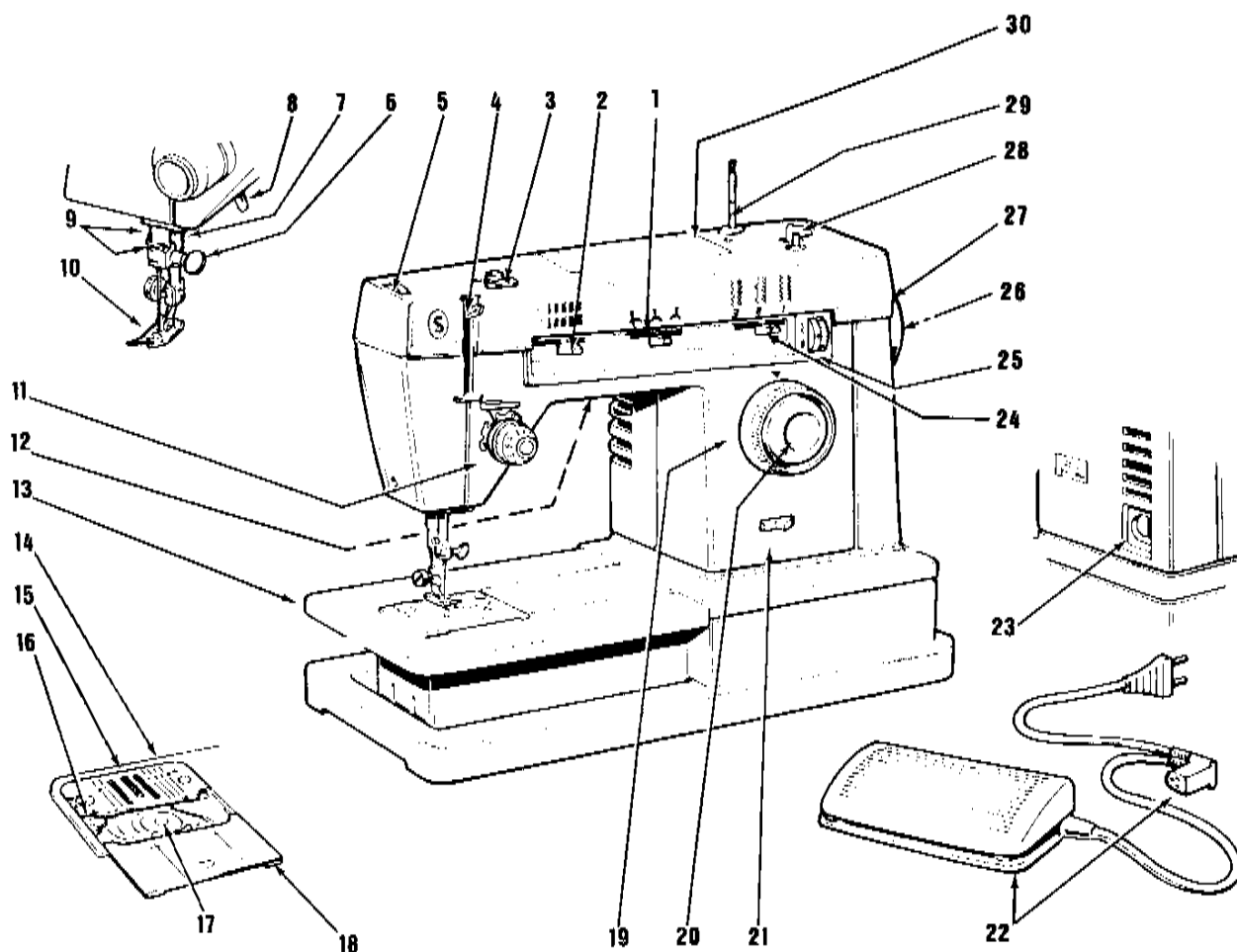

## ***principal parts***

- |                                  |                                                |                                                 |
|----------------------------------|------------------------------------------------|-------------------------------------------------|
| 1. Needle Position Selector      | 12. Sewing Light                               | 21. Power and Light Switch                      |
| 2. Stitch Width Selector         | 13. Extension Bed                              | 22. Electrical Connections and Speed Controller |
| 3. Bobbin Winder Tension         | 14. General Purpose Needle Plate               | 23. Machine Plug Receptacle                     |
| 4. Take-up Lever                 | 15. Feed                                       | 24. Pattern Group Selector                      |
| 5. Pressure Dial                 | 16. Bobbin Case Holder                         | 25. Stitch Balance Control Dial                 |
| 6. Needle Clamp                  | 17. Transparent Bobbin                         | 26. Hand Wheel Knob                             |
| 7. Thread Cutter                 | 18. Slide Plate                                | 27. Hand Wheel                                  |
| 8. Presser Foot Lifter           | 19. Stitch Length Selector and Buttonhole Dial | 28. Bobbin Winder Spindle                       |
| 9. Thread Guides                 | 20. Reverse Stitch Push Button                 | 29. Telescopic Spool Pin and Felt               |
| 10. General Purpose Presser Foot |                                                | 30. Carrying Handle                             |
| 11. Tension Dial                 |                                                |                                                 |

# Chapter 1. Getting to Know Your Machine

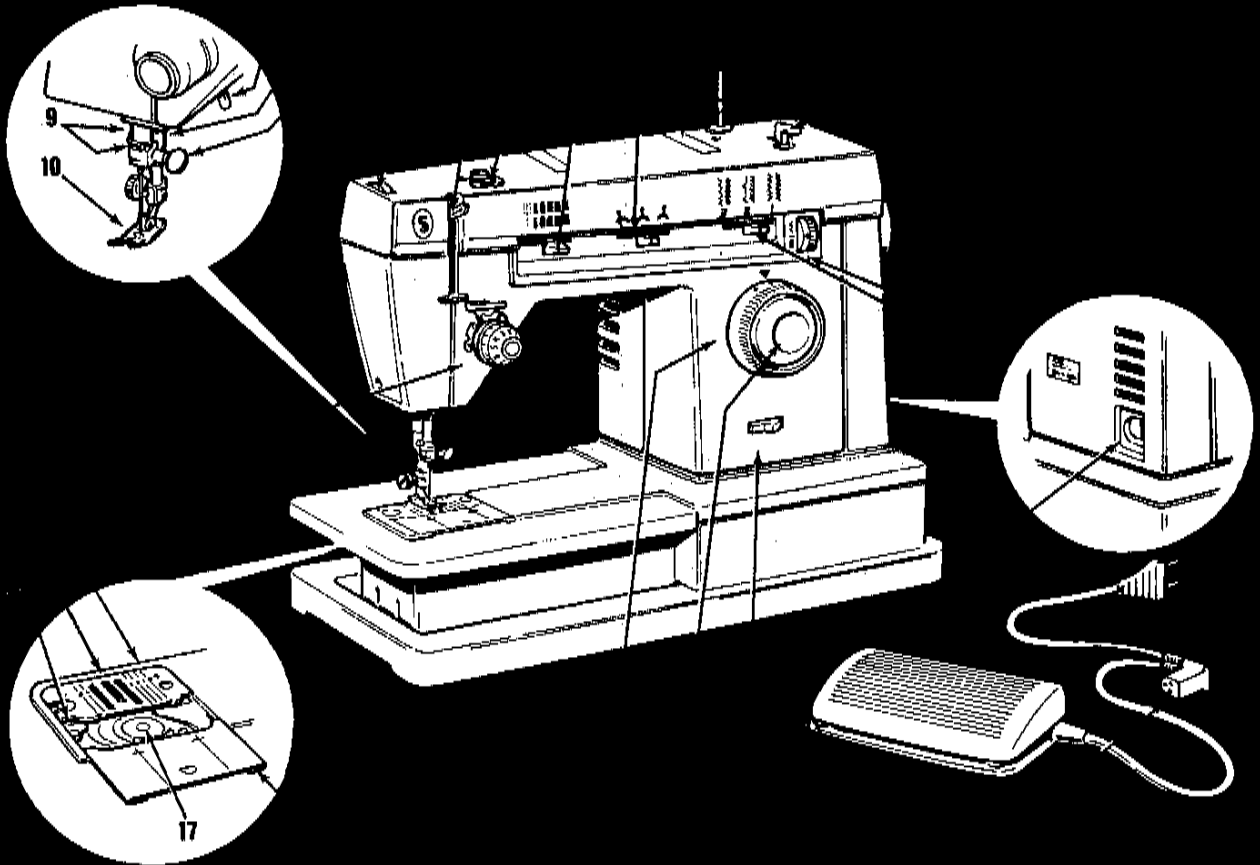

## accessories

The accessories that come with your sewing machine are designed to help you do many kinds of sewing easily.

### 1. Transparent Bobbins (No. 172336).

### 2. Needles

- Style 2020 in your machine when delivered is for general sewing.
- Style 2045 is used for sewing knits, stretch fabrics and elastic.
- Style 2025 for twin-needle decorative stitching on woven and knit fabrics.

### 3. Buttonhole Foot

is used to make bar tack buttonholes of any length in four steps.

### 4. Special Purpose Foot.

Used for all kinds of decorative zig-zag stitching.

### 5. Zipper Foot

for inserting zippers and stitching corded seams.

### 6. General Purpose Foot

on your machine when delivered, is used for all utility sewing, with either straight or zig-zag stitching.

### 7. General Purpose Needle Plate

on your machine when delivered is used with all presser feet.

### 8. Snap-in Feed Cover

for button sewing and free-motion work.

### 9. Spool Pin Extension

used for tubes of thread.

### 10. Blindstitch Hem Guide.

Use this with the general purpose foot to position and guide the hem.

### 11. Detachable Spool Pin

for decorative twin-needle stitching and two-thread topstitching.

### 12. Felt

to help thread unwind smoothly.

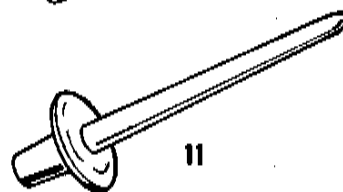
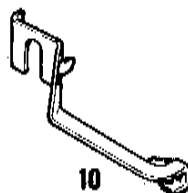
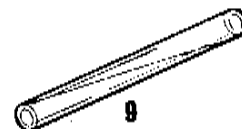
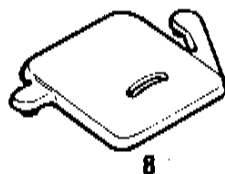
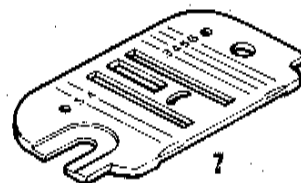
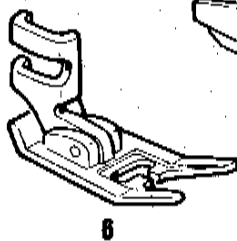
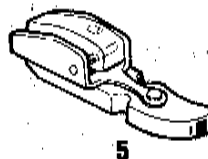
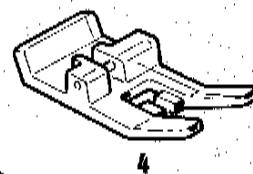
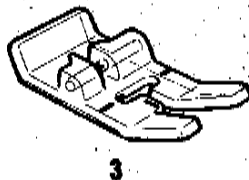
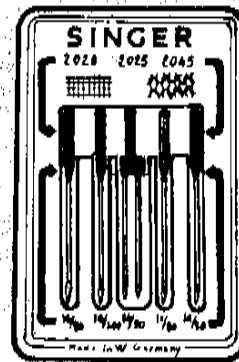
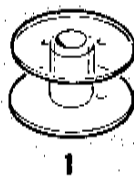

# Chapter 2. Getting Ready to Sew

## *choosing and changing accessories*

### CHANGING THE NEEDLE

- Raise needle to its highest point by turning the hand wheel *toward you*. Loosen needle clamp screw **A** and remove the needle.
- Insert new needle up into clamp **B** as far as it will go, with the flat side of the needle to the back.
- Tighten needle clamp screw.

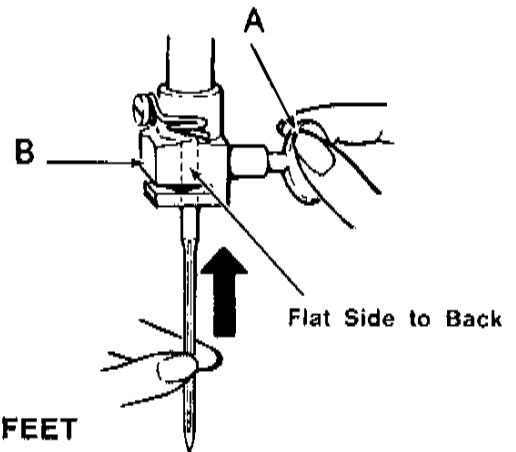

### CHANGING PRESSER FEET Snap-on Presser Feet

The presser feet furnished with your machine snap on and off a common shank.

Raise needle to highest position by turning the hand wheel *toward you*. Raise presser foot.

#### To Remove and Replace Foot

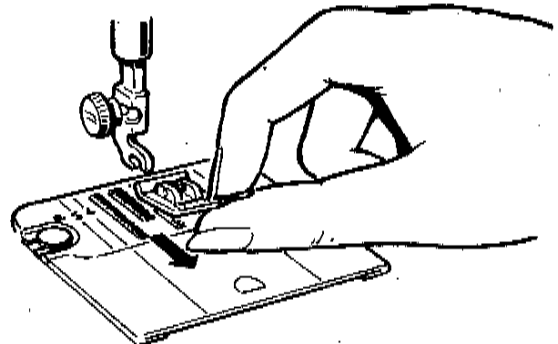
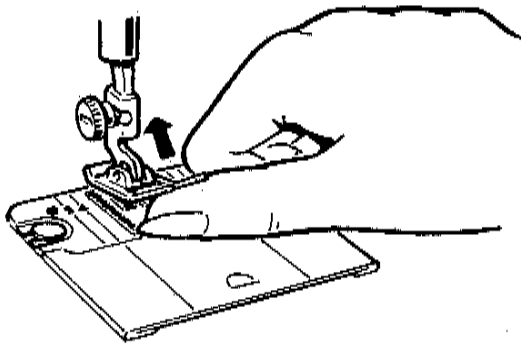

1a. Press toe of presser foot upward as far as it will go.

1b. Then snap down to remove.

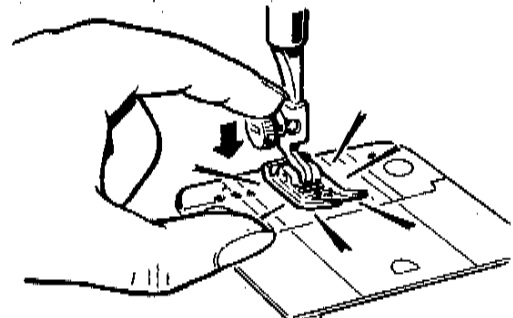
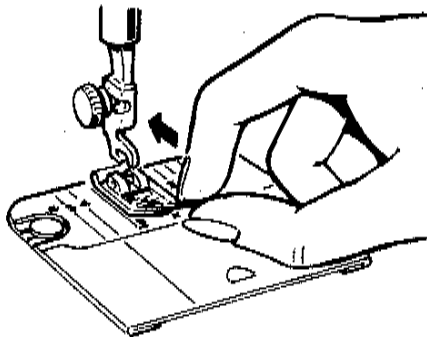

2. Centre the new presser foot under the shank **C** and *lower the presser foot lifter* so that the shank fits over the presser foot pin.

3. Press presser foot screw down *firmly* until foot snaps into place.

## REMOVING AND REPLACING NEEDLE PLATE

- Raise presser foot.
- Raise needle to highest position.
- Open slide plate. Place thumb under right side of needle plate, lift it up and withdraw it to right.
- Replace needle plate under clamping pin **A**, push it gently to the left and press down until it snaps into place.

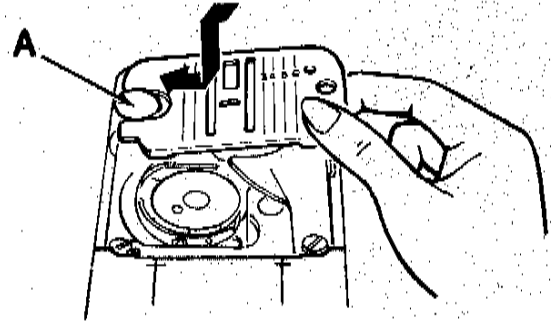
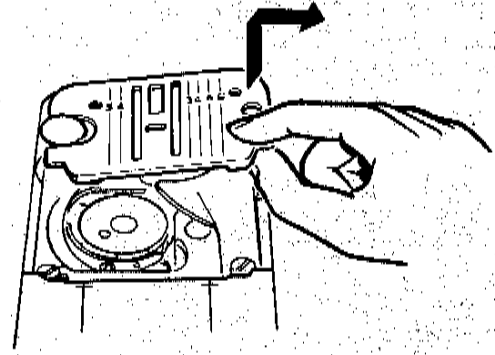

## ATTACHING SNAP-IN FEED COVER

- Raise presser foot.
- Raise needle to highest position by turning hand wheel *toward you*. Open slide plate.
- Slide snap-in feed cover away from you over needle plate until points **B** and **C** are positioned directly over holes in needle plate as illustrated. Snap in point **B**. Then push point **C** in toward point **B** until it snaps into place. Close slide plate. To remove, open slide plate then simply lift up front edge of feed cover.

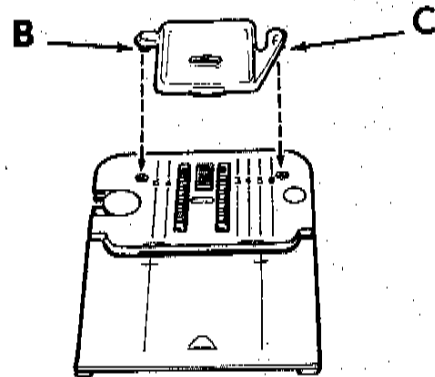

## ATTACHING BLINDSTITCH HEM GUIDE

- Raise presser foot, loosen presser foot screw with a coin and slip blindstitch hem guide between screw and shank of the general purpose foot.
- Be sure underside of the guide clears the slide plate and front of foot.
- Tighten screw with a coin.

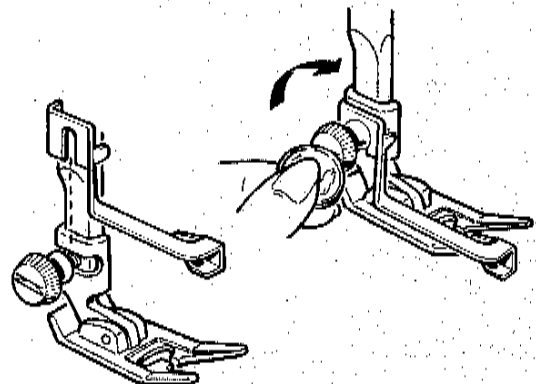



## FABRIC WEIGHT TABLE

There are many types of fabrics around the world, each manufactured with a specific fibre and weight. The fabric below have been classified according to weight to give a small sample of what is available for purchase.

<b>SILK</b> (Woven)	Chiffon, Organza, Tulle	Net, Lace, Ninon	Velvet, Crepe de Chine, Shantung, Faille
(Knit)			Jersey
<b>RAYON</b> (Woven)	Tulle	Net, Lace	Velvet, Taffeta, Satin
(Knit)			Ciré
<b>COTTON</b> (Woven)	Voile, Tulle	Net, Lace	Challis, Organdy, Muslin, Batiste, Dimity, Lawn, Percale, Eyelet, Gingham, Piqué, Poplin
(Knit)			Jersey
<b>WOOL</b> (Woven)			Cashmere, Flannel, Mohair, Felt, Crepe
(Knit)			Jersey
<b>SYNTHETIC</b> (Woven)	Chiffon, Organza, Tulle	Net, Lace, Ninon, Crepe de Chine	Crepe; Velvet, Taffeta, Satin
(Knit)			Raschel, Single Knit, Sweater Knit, Bonded Knit, Tricot, Ciré
<b>SYNTHETIC BLENDS</b> (Woven)		Voile	Broadcloth, Batiste, Eyelet, Gingham, Poplin
(Knit)			Single Knit
<b>LEATHER</b>			Kidskin, Patent, Chamols, Imitation- Leathers & Suedes, Leather, Suede
<b>PLASTIC</b>		Plastic Film	Plastic Film
<b>VINYLS</b>			

Refer to this table to determine the weight and type of fabric you will be using in order to select the correct needle and thread combination.

For correct needle and thread combination for your fabric, refer to the Fabric, Thread and Needle Table on the following page.

Velvet, Crepe de Chine, Shantung, Suiting, Brocade

Velvet, Taffeta, Satin, Crepe

Brocade, Taffeta, Satin, Crepe

Velveteen, Corduroy, Velvet, Fleece, Velour, Terry, Chintz

Corduroy, Denim, Ticking, Canvas, Linen, Drapery Fabric, Burlap

Denim, Duck, Canvas, Sailcloth, Upholstery Fabric

Stretch Velours<sup>Δ</sup>, Stretch Terry<sup>Δ</sup>  
<sup>Δ</sup> Usually contain some synthetic fibres also.

Suiting, Flannel, Gabardine, Felt, Serge, Mohair

Suiting, Tweed, Duffle

Coating, Blanketing

Jersey

Velvet, Crepe, Taffeta, Satin, Gabardine

Jacquard, Double Knit, Sweater Knit, Bonded Knit, Tricot, Spandex, Stretch Terry, Stretch Velour, Deep Pile, Fake Furs

Double Knit, Hellenca, Fake Furs

Linen Type, Poplin, Corduroy, Gabardine

Denim, Gabardine, Drapery Fabric

Terry Knit

Double Knit

Patent, Imitation-Leathers & Suedes, Leather, Suede, Reptile

Buckskin, Calfskin, Suede, Reptile

Upholstery Leather

Bonded Vinyl (Knit Back), Patent, Embossed, Printed

Upholstery Vinyl

Upholstery Vinyl

## FABRIC, THREAD AND NEEDLE TABLE

Choosing the correct needle and thread for your fabric is of utmost importance. Correct choice will make the difference in the wear and appearance of your new garment. The Fabric Weight Table on the previous page, and the Fabric, Thread and Needle Table below are practical guides to needle and thread selection. Refer to them before starting a sewing project. Be sure to use the same size and type of thread in both needle and bobbin.

To select the correct needle and thread for your fabric, first refer to the Fabric Weight Table to determine the weight and type of the material you are using.

Next, refer to the Fabric Thread and Needle Table.

FABRIC	FINE COTTON		FINE SILK		MEDIUM COTTON	
	THREADS	NEEDLES	THREADS	NEEDLES	THREADS	NEEDLES
<b>SILK</b>	Fine Silk Fine Mercerized	2020-9	Fine Silk Fine Mercerized	2020-9	Fine Silk Fine Mercerized	2020-11
<b>RAYON</b>	Fine Silk Fine Mercerized	2020-9	Fine Silk Fine Mercerized	2020-9	Fine Silk Fine Mercerized	2020-11
<b>COTTON</b>	Fine Cotton Fine Mercerized	2020-9	Fine Cotton Fine Mercerized	2020-9	Medium Cotton Med. Mercerized	2020-11
<b>WOOL</b>			Fine Silk Fine Mercerized	2020-11	Fine Silk Fine Mercerized	2020-11
<b>SYNTHETIC</b>	Fine Synthetic	2020-9	Fine Synthetic	2020-9	Fine Synthetic	2045-11
<b>SYNTHETIC BLENDS</b>	Fine Synthetic	2020-9	Fine Synthetic	2020-9	Fine Synthetic	2045-11
<b>LEATHER</b>					Med. Mercerized Med. Synthetic	2032-11
<b>PLASTIC</b>					Fine Mercerized Fine Synthetic	2020-11
<b>VINYLS</b>					Fine Mercerized Fine Synthetic	2020-11

Find the fabric you are using in Type of Fabric column at left (silk, rayon, etc.). Then locate the fabric weight column (filmy, sheer, etc.) for your fabric at top of table. Read across from Type of Fabric column to correct weight of fabric column. There, the correct thread and needle choice for your fabric will be found.

Example: If you are sewing a medium weight wool, find wool in Type of Fabric column. Read across to Medium (weight) column and you will see that a medium silk or mercerized thread and a size 2020-14 needle are to be used.

*You should follow the recommendations in this instruction book and on the needle package for correct style and size of needle for different types and weights of fabric.*

MEDIUM		HEAVY		VERY HEAVY	
THREADS	NEEDLES	THREADS	NEEDLES	THREADS	NEEDLES
Medium Silk Medium Mercerized	2020-11	Heavy Silk Heavy Mercerized	2020-14	Heavy Silk	2020-14
Medium Synthetic Medium Mercerized	2020-11	Heavy Synthetic Heavy Mercerized	2020-14	Heavy Synthetic Heavy Mercerized	2020-14
Medium Cotton Medium Mercerized	2020-14	Heavy Cotton Heavy Mercerized	2020-16	Heavy Cotton Heavy Mercerized	2020-18
Medium Silk Medium Mercerized	2020-14	Heavy Mercerized	2020-16	Heavy Mercerized	2020-16
Medium Synthetic	2045-14	Heavy Synthetic	2045-16	Heavy Synthetic	2020-16 or 18
Medium Synthetic	2045-14	Heavy Synthetic	2045-16	Heavy Synthetic	2020-16 or 18
Medium Mercerized Medium Synthetic	2032-14	Heavy Mercerized Heavy Synthetic	2032-16	Heavy Mercerized Heavy Synthetic	2032-18
Medium Mercerized Medium Synthetic	2020-11	Medium Mercerized Medium Synthetic	2020-14	Heavy Mercerized Heavy Synthetic	2020-16
Medium Mercerized Medium Synthetic	2020-11	Medium Mercerized Medium Synthetic	2020-14	Heavy Mercerized Heavy Synthetic	2020-16

## needle-fabric combinations

Correct needle selection is closely related to stitch quality and appearance. Damaged fabric is almost always caused by a needle that is bent, burred or that is an inappropriate style for the fabric and thread you are using.

The three types of needles most commonly used are the regular, ball point, and wedge. To obtain good results, the correct size and type of needle for the fabric and thread you are using must be chosen. Refer to the Fabric, Thread and Needle Table, page 8.

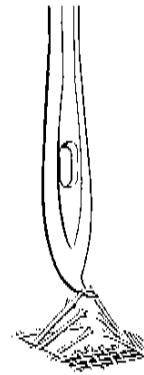

Result of Using a Bent Needle

## operating the machine

### CONNECTING MACHINE

- Before plugging in your machine, be sure the electrical information on the side of the machine **A**, below the hand wheel agrees with the range marked on your electrical meter.
- Connect plug **B** to machine and plug **C** to your socket outlet.
- To turn the machine and light on or off, press switch as shown.
- To run the machine and control speed, press the speed controller **D** with your foot. The harder you press, the faster the machine will sew.

**CAUTION:** Disconnect the power line plug from the socket outlet when changing needles, feet or needle plates or when leaving the machine unattended. This eliminates the possibility of starting the machine by accidentally pressing the speed controller.

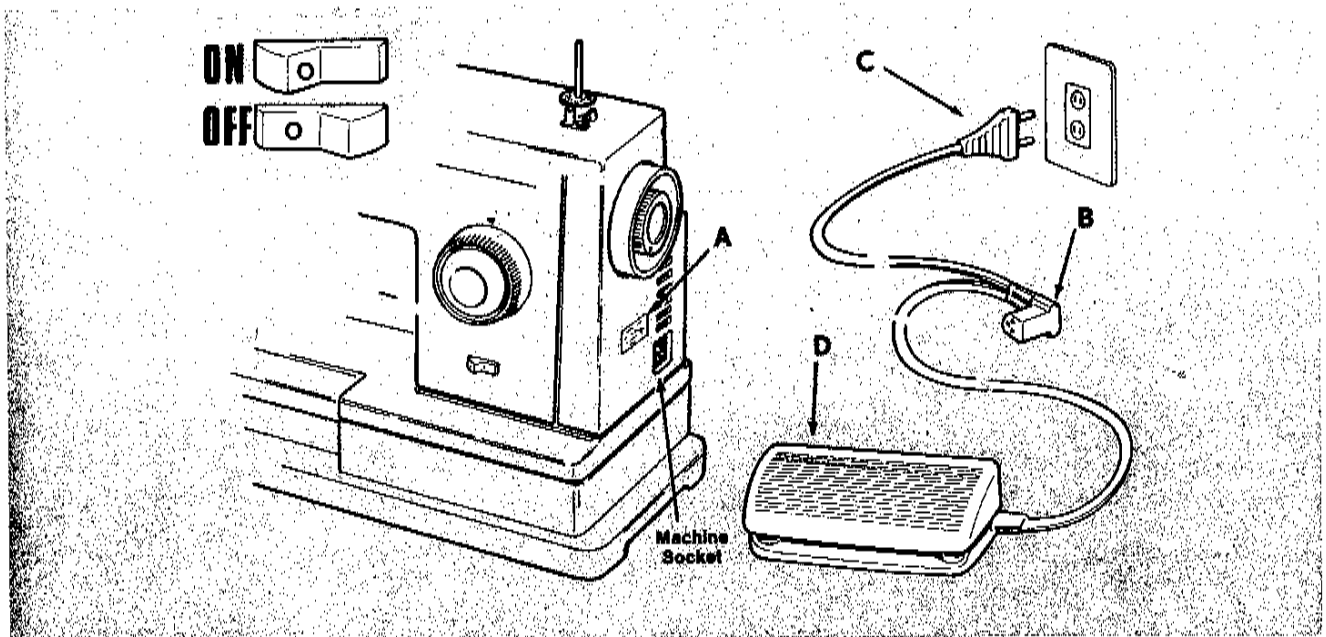

**IMPORTANT** - Machines for Great Britain and some other countries having similar wiring standards are shipped from the factory without a plug for connection to the mains.

The wires in this mains lead are coloured in accordance with the following code:

**Blue: Neutral (N)**

**Brown: Live (L)**

As the colours of the wires in the mains lead of this appliance may not correspond with the coloured markings identifying the terminals in your plug, proceed as follows:

The wire which is coloured blue must be connected to the terminal which is marked with the letter **N** or coloured black.

The wire which is coloured brown must be connected to the terminal which is marked with the letter **L** or coloured red.

If a 13 amp (BS 1363) plug is used a 3 amp fuse must be fitted, or if any other type of plug is used a 5 amp fuse must be fitted either in the plug or adaptor or at the distribution board.

## the bobbin thread

Your sewing machine uses two threads to form a stitch. The upper thread comes from the spool and is threaded through the eye of the needle. The lower thread comes from the bobbin. Wind the bobbin before threading the machine.

### WINDING THE BOBBIN

#### Preparation Steps

1. Raise the presser foot and turn hand wheel toward you until needle is in highest position.
2. Loosen hand wheel knob **A** by turning it toward you with the right hand while holding hand wheel with the left hand.
3. Open slide plate and lift out bobbin.
4. Place spool pin felt on pin.

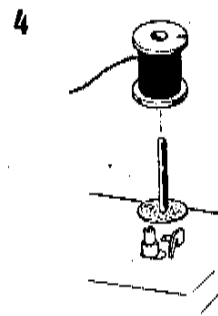
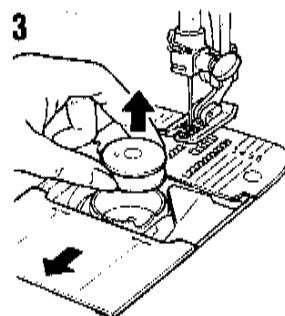
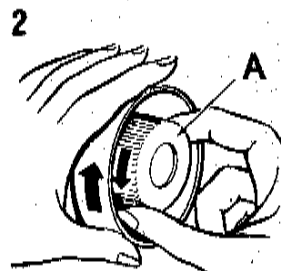
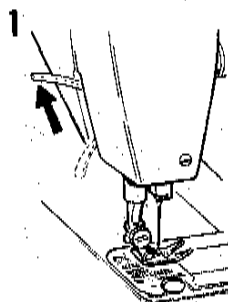

#### Winding Steps

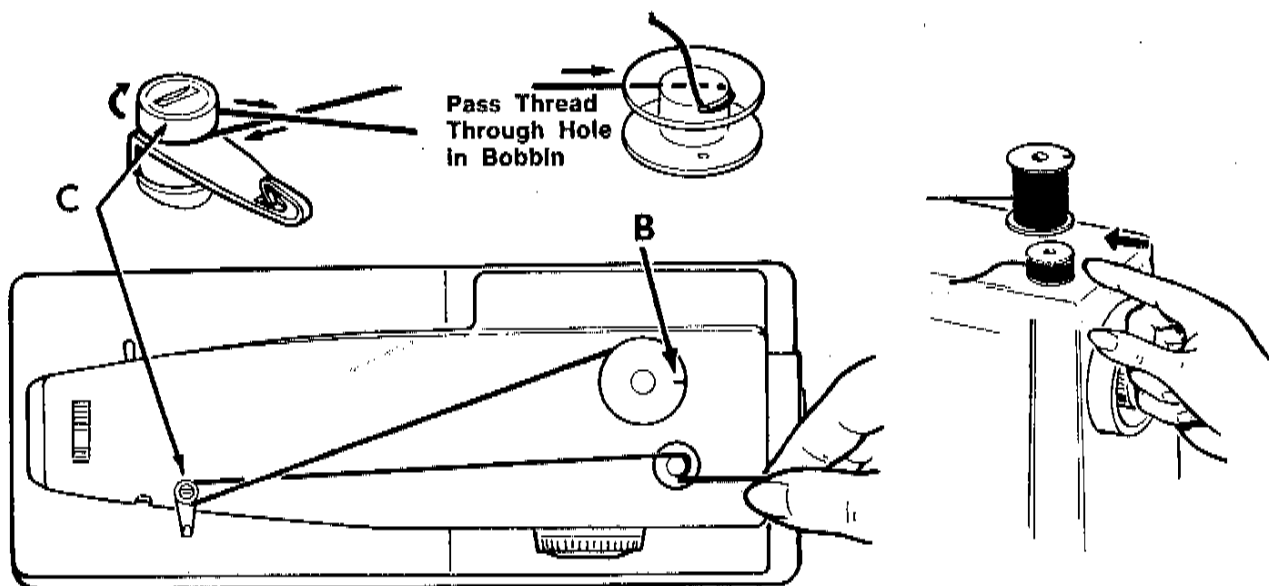

- Place thread spool on spool pin with thread retaining slit **B** on top. (Break paper at the end of spool if necessary). If you are using a tube of thread affix spool pin extension to spool pin to ensure even flow of thread.
- Lead thread around bobbin winder tension disc **C** and through small hole in bobbin from inside out.
- Place bobbin on spindle and push bobbin to right to engage bobbin winder.
- Hold thread end as shown and start the machine. Cut off thread end after a few coils have been wound.
- When required amount of thread has been wound (winding will stop when bobbin is full), stop the machine and cut connecting thread.
- Push bobbin to left and remove bobbin from spindle.
- Hold hand wheel and tighten hand wheel knob.

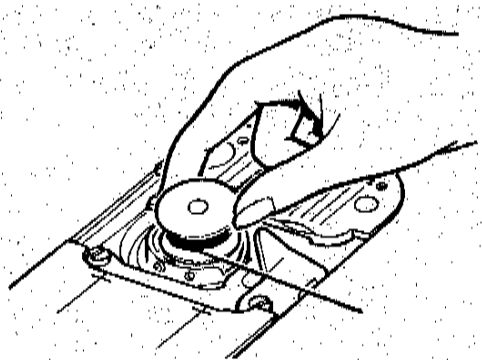

1. Hold bobbin so that thread unwinds in the direction shown, and put bobbin into bobbin case.

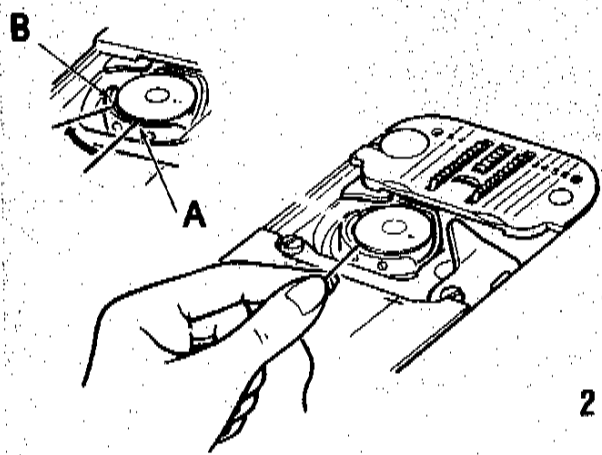

2. Pull thread into notch **A**, draw it back under the tension spring and back into slot **B**.

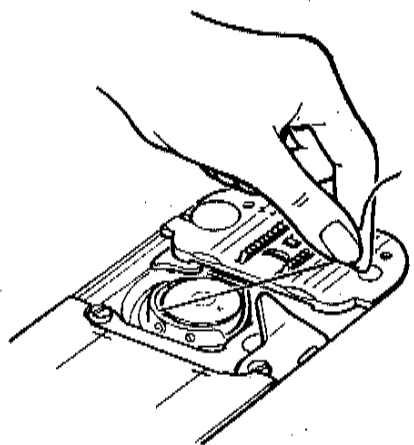

3. Draw approximately 10 cm (4 inches) of thread across the bobbin.

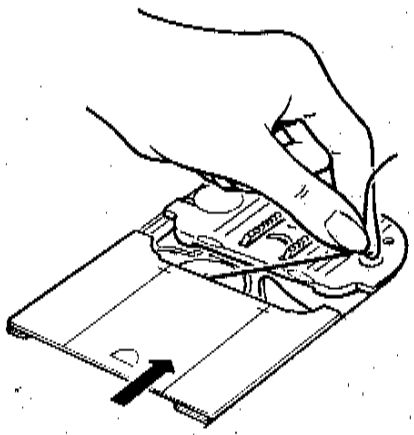

4. Close slide plate allowing thread to enter slot between the needle plate and slide plate.

## threading the machine

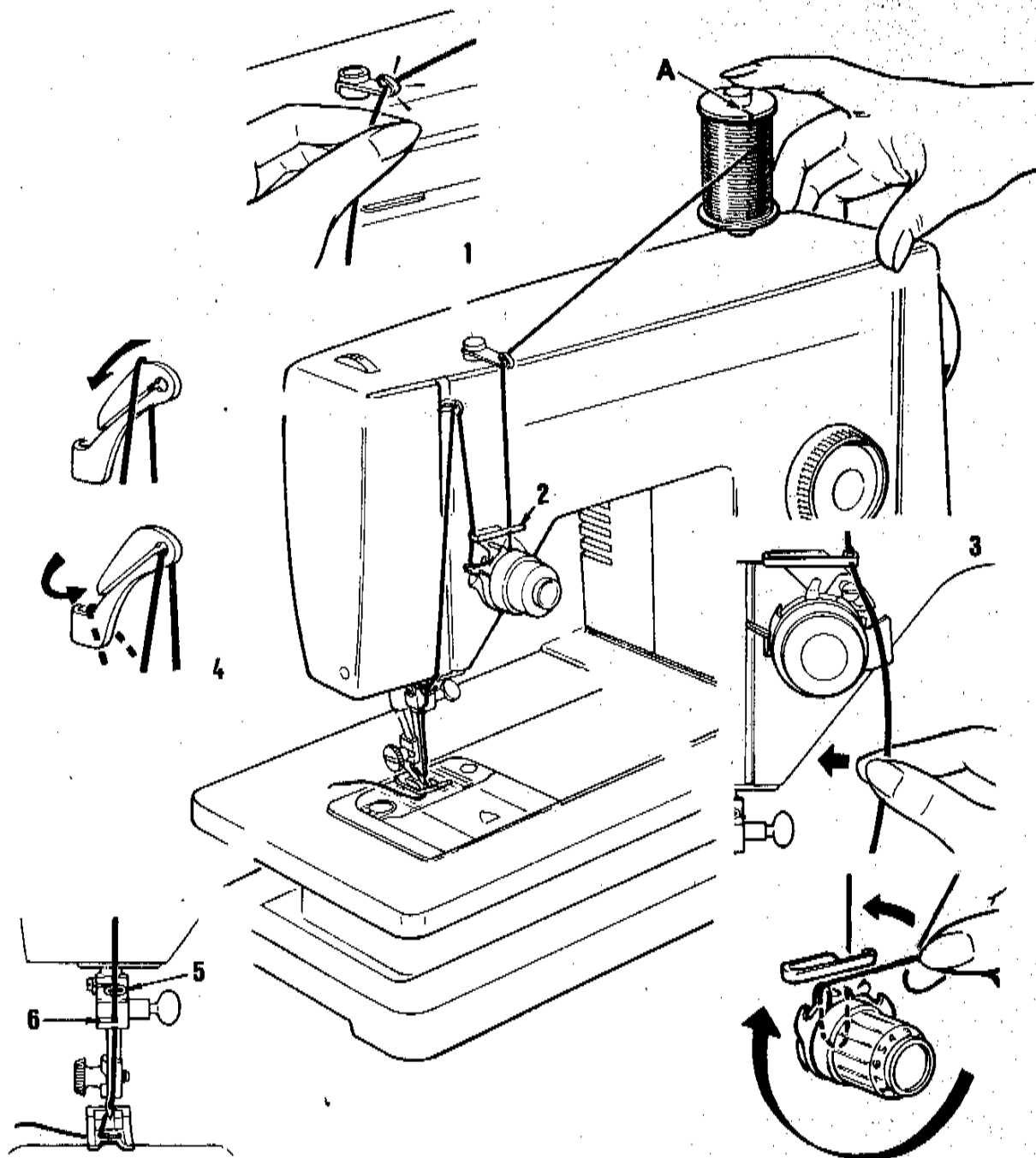

- Raise the presser foot to release tension discs and make sure needle and take-up lever are in highest position.
- Place spool pin felt from accessories over spool pin, and place spool of thread on spool pin over felt, with spool thread retaining slit A on top.
- Keep right hand on spool of thread to hold firmly in place while threading machine.
- Snap thread into upper thread guide 1.
- Pass thread through point 2.
- Thread the needle thread tension 3. Slide thread over metal plate into tension discs. Lead thread under needle thread tension and through tension wire by firmly pulling thread straight up.
- Pull thread to right behind point 2 guiding thread up toward take-up lever.
- Pass thread through points 4 to 6 as shown.
- Thread needle from front to back and draw about 10 cm (4 inches) of thread through eye of needle.



## RAISING THE BOBBIN THREAD

Now that you have wound the bobbin and threaded the needle, raise the bobbin thread through the hole in the needle plate.

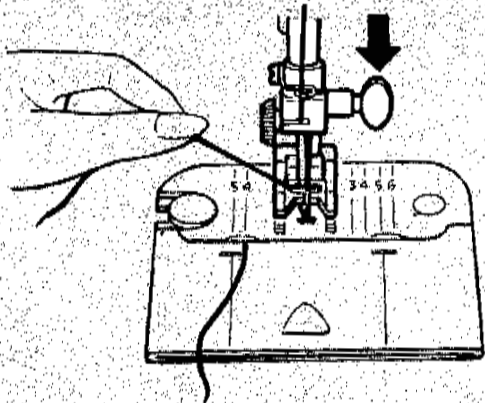

1. Hold needle thread lightly with left hand and turn hand wheel slowly *toward you* so that needle enters needle plate.

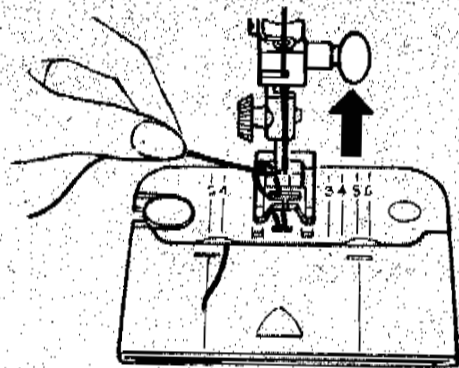

2. Continue turning hand wheel and holding needle thread until needle rises and brings up bobbin thread in a loop.

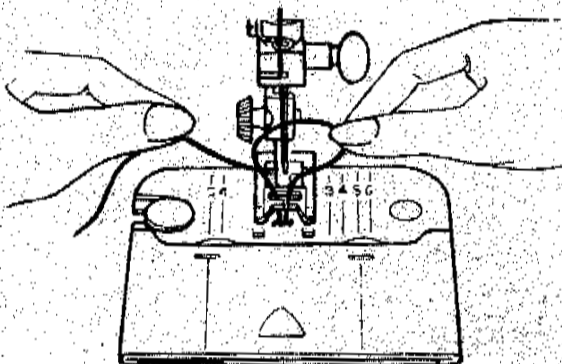

3. Undo the loop with your fingers.

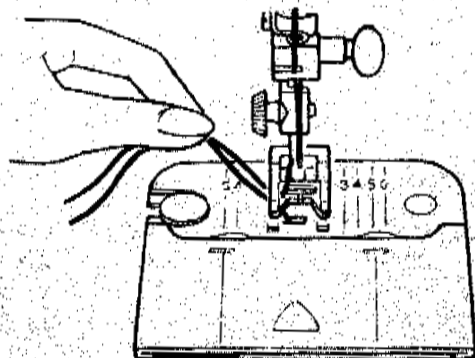

4. Place both needle and bobbin threads under the foot and draw them to back of machine.

# Chapter 3. Straight Stitching

## *adjusting machine stitch to suit your fabric*

Before you move the selectors to set your machine for straight stitching, turn the hand *toward you* until the needle is above the needle plate.

### SETTING SELECTORS

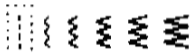
- 
- Set needle position selector at 
  - Set stitch width selector at 
  - Set stitch length: .5 - 4 to suit fabric
- 

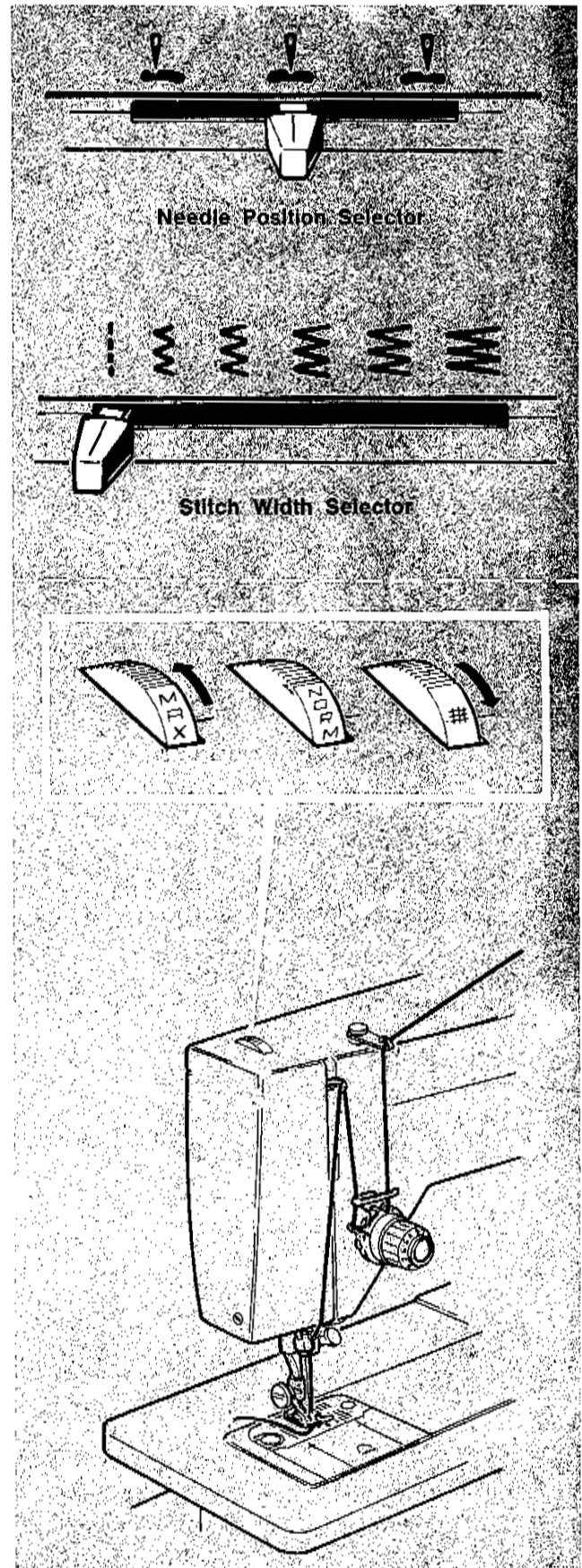

### REGULATING PRESSER FOOT PRESSURE

The pressure dial regulates the pressure that the presser foot exerts on the fabric. Correct pressure is important because it enables the fabric to feed smoothly and evenly, without being marked.

The **NORM** (normal) setting is an all purpose setting that can be used for sewing a wide variety of fabrics of different weights and textures. Intermediate notched settings above and below **NORM** (normal) are also provided. When you need extra control to sew, regulate the setting to heavier or lighter pressure to suit the fabric being used.

*Lower the foot before setting pressure.*

- **To increase pressure**, turn dial from **NORM** toward **MAX**.
- **To decrease pressure**, turn dial from **NORM** toward **#3**.
- **For darning**, set dial on **#3**.

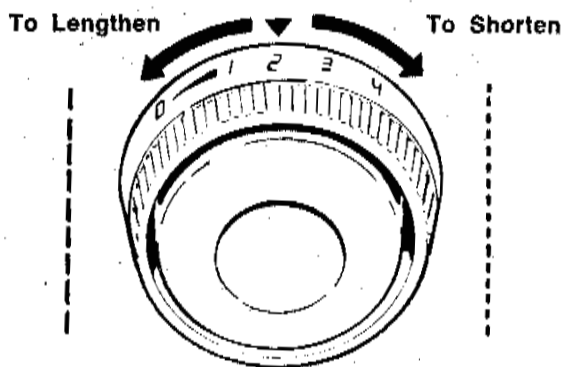

Adjusting Stitch Length

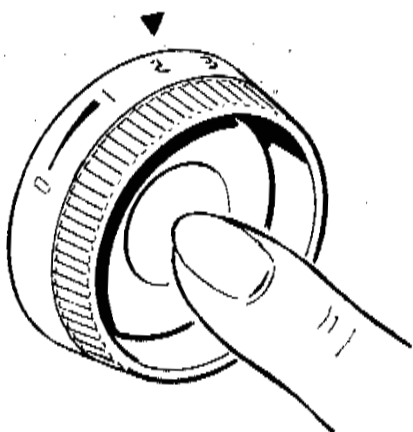

Reverse Stitch Push Button

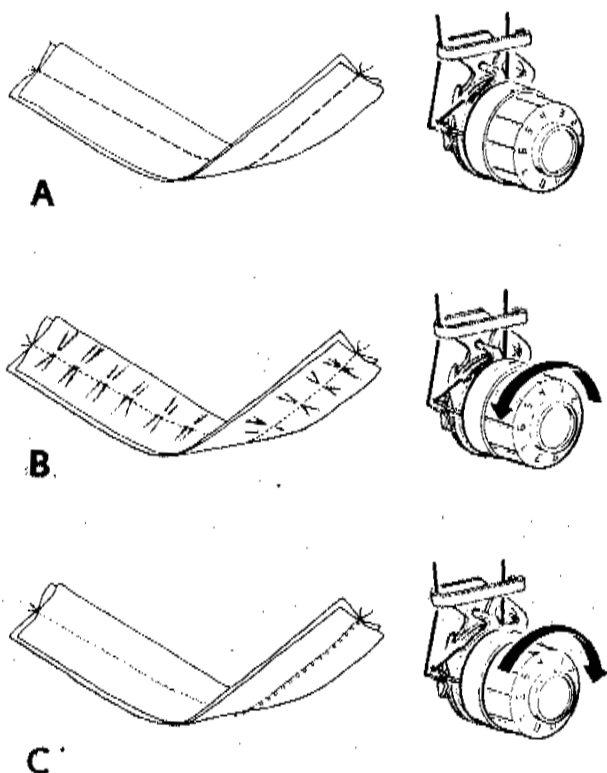

## ADJUSTING STITCH LENGTH

The stitch length dial controls the length of stitches. The numbers around the edge of the dial express stitch length in mm; *the lower the number, the shorter the stitch*. Generally, shorter stitches are best for lightweight fabric; longer stitches for heavy fabric. The area from 0 to 1 is used for the adjustment of zig-zag satin stitching (see page 21).

### Setting the Dial

- Turn dial so that stitch length desired is positioned under ▼ symbol.
- **To shorten stitch length**, turn dial clockwise to a lower number.
- **To lengthen stitch length**, turn dial counter-clockwise to a higher number.

## REVERSE STITCHING

**For reverse stitching**, depress push button located in centre of dial, hold in until reverse stitching is completed, then release push button. Push button can be depressed while machine is sewing.

**Note:** Reverse stitching cannot be done when using a stretch stitch pattern.

## NEEDLE THREAD TENSION

Correct tension is important because too much or too little will weaken your seams or cause your fabric to pucker. Make a test sample with the fabric and the thread you plan to use and examine it. A well balanced stitch, as shown in illustration **A**, will have the needle and bobbin threads locked between the two layers of fabric with no loops on top or bottom and no puckers. The tension dial regulates the degree of tension on your needle thread. Set it according to the type of thread and fabric you use. The numbers on the dial eliminate guesswork.

If the fabric puckers **B**, decrease tension. If the stitches in your test sample look loose **C**, increase needle thread tension.

- **To decrease** tension, turn dial to lower number.
- **To increase** tension, turn dial to higher number.

## sewing a seam

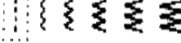
- Needle Position: 
- Stitch Width: 
- Stitch Length: To suit fabric
- General Purpose Needle Plate
- General Purpose Foot

1. Raise presser foot. Pull thread back under presser foot leaving at least 10 cm (4 inches) of thread.

2. Position needle approximately 1.2 cm (1/2 inch) from fabric edge. Then lower presser foot and backstitch almost to the edge of the fabric for reinforcement by stitching in reverse direction. For additional information on reverse stitching refer to page 16. Stitch forward to end of seam and stop machine before the end of stitching line. (Do not sew beyond edge of fabric).

3. Raise needle by turning hand wheel toward you. Press reverse stitch push button and back stitch 1.2 cm (1/2 inch) to reinforce end of stitching.

4. Raise needle by turning hand wheel toward you. Raise foot and remove fabric by drawing it to the back and to the left. Cut threads on thread cutter at rear of presser bar.

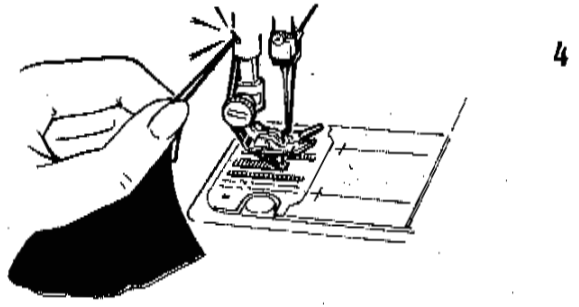
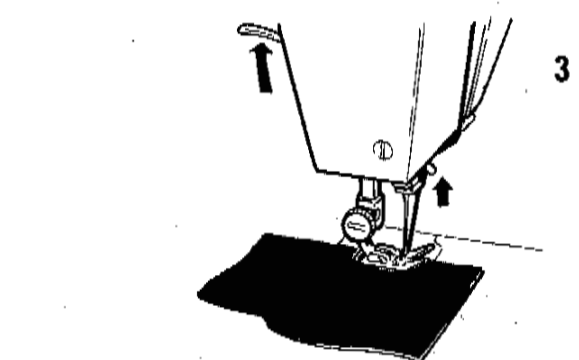
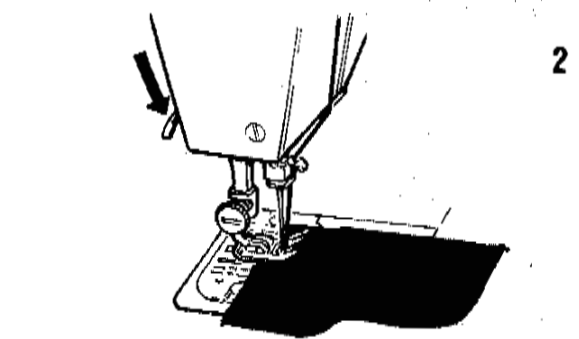
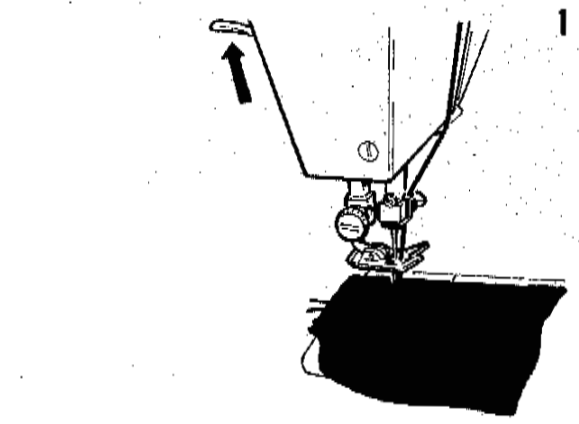

## KEEPING THE SEAM STRAIGHT

To keep the seam straight, use one of the numbered guidelines on the needle plate. The dimensions they represent are shown in the illustration.

**CAUTION:** Because of the up and down movement of the needle, you must work carefully and watch the sewing area when operating the machine.

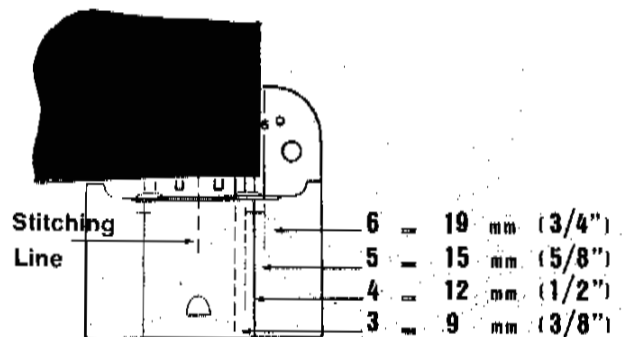

## applications

### ZIPPER INSERTION

How the zipper is inserted will depend on the type of the garment and the location of the zipper. With the adjustable zipper foot, you will find it easy to sew an even line of stitching close to the zipper.

The zipper foot can be used either to the left or right of the needle, depending on where the bulk of the garment is placed.

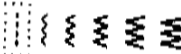
- 
- Needle Position: 
  - Stitch Width: 
  - Stitch Length: To suit fabric
  - General Purpose Needle Plate
  - Zipper Foot
- 

### Adjusting the Zipper Foot

When the zipper is to the **right** of the needle.

- Before attaching the zipper foot slide the adjusting spacer to the left (illustration **A**).
- Snap on the zipper foot as instructed on page 4.
- Check the position of the foot by lowering the needle into the side notch of the foot, making sure it clears the foot.

When zipper is to the **left** of the needle, adjust the foot to the **right** of the needle in the same way (illustration **B**).

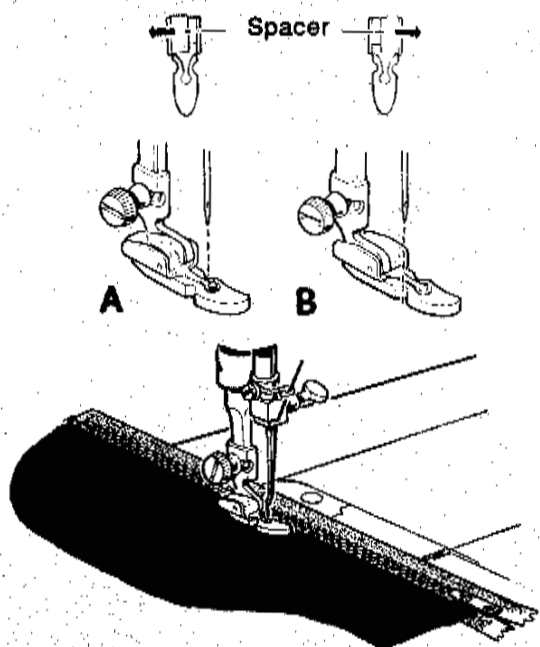

## DARNING

### With Embroidery Hoop

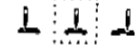
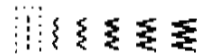
- 
- Needle Position: 
  - Stitch Width: 
  - Stitch Length: 0
  - Snap-in Feed Cover
  - No Presser Foot or Presser Foot Shank
  - Presser Bar: Lowered
- 

- Insert snap-in feed cover plate as instructed on page 5.
- Trim ragged edges from area to be darned and centre worn section in embroidery hoop designed for machine use.
- Position hoop under the needle *and lower presser bar to engage tension*. Hold needle thread loosely with left hand, turn hand wheel over and draw bobbin thread up through fabric. Hold both thread ends and lower needle into fabric. Take a few stitches to secure. Snip off thread ends close to fabric.
- Outline area to be darned with straight stitches for reinforcement.
- Stitch across opening, moving hoop under needle at a slight angle from lower left to upper right. Keep lines of stitching closely spaced and even in length. When opening is filled, cover area with crosswise lines of stitching.

This method of controlling fabric movement with an embroidery hoop should be done with the extension bed on the machine and may be used to do embroidering or monogramming.

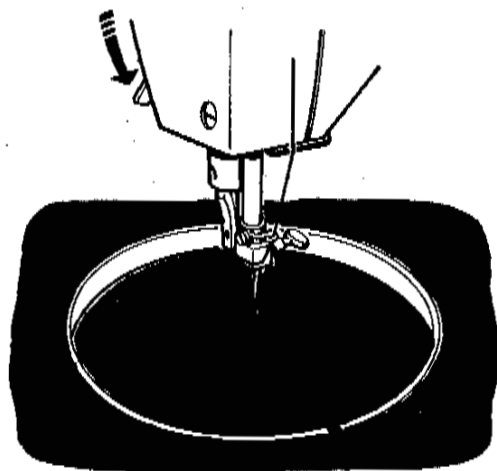

# Chapter 4. Basic Zig-Zag Stitching

## *adjusting machine stitch to suit your fabric*

You can do functional as well as decorative zig-zag stitching with your sewing machine.

### **How to set selectors**

#### **PATTERN GROUP SELECTOR**

*Before moving selector, make sure needle is out of the fabric.*

##### **For plain zig-zag stitching:**

- Set stitch width selector on  $\downarrow$  (straight stitch)
- Set pattern group selector under  $\diagup$ .

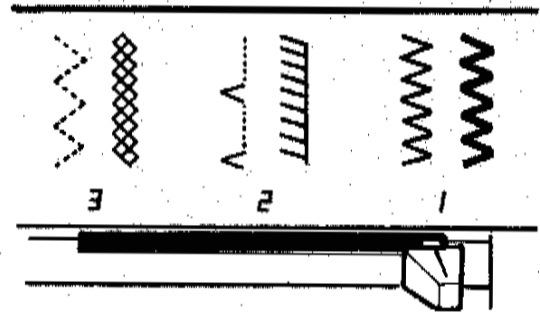

**Pattern Group Selector**

- 
- Pattern Group Selector:  $\diagup$
  - Needle Position:  $\downarrow$  (centre)
  - Stitch Width:  $\downarrow$  (straight)
  - Stitch Length: 5 - 4 to suit fabric
  - General Purpose Needle Plate
  - General Purpose Foot
- 

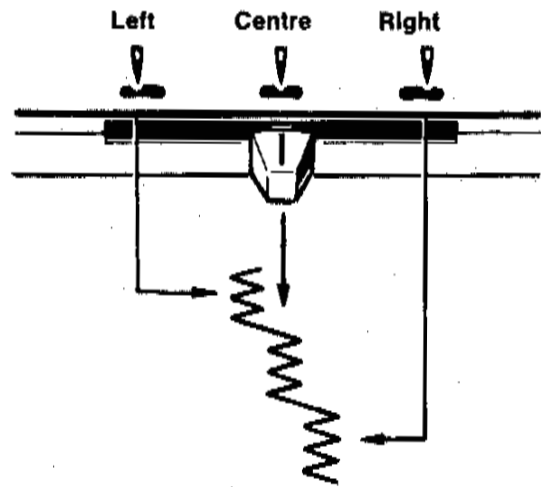

**Needle Position Selector**

#### **NEEDLE POSITION SELECTOR**

*Before moving selector, make sure needle is out of the fabric.*

Most of your zig-zag stitching will be done in centre  $\downarrow$  needle position.

Left  $\downarrow$  and right  $\downarrow$  settings are used for special stitch placement, as in button sewing.

#### **STITCH WIDTH SELECTOR**

*Before moving selector, make sure needle is out of the fabric.*

To produce a plain zig-zag or a decorative stitch, the stitch width selector is moved from its straight stitch position  $\downarrow$  to any of its other five positions. The further you move the selector lever toward the right, the wider your stitch will be.

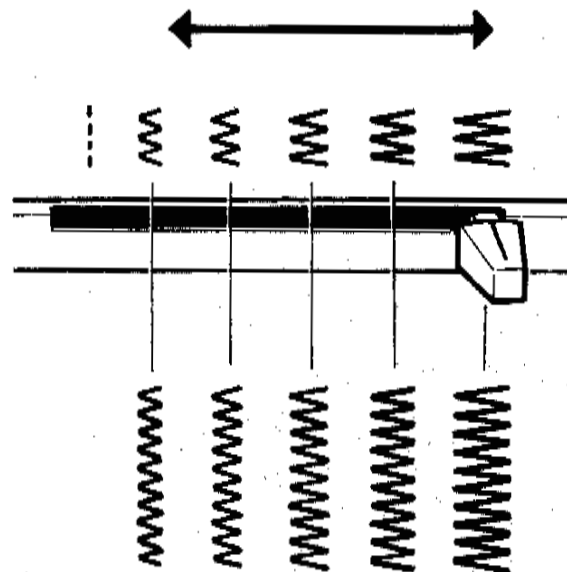

**Stitch Width Selector**

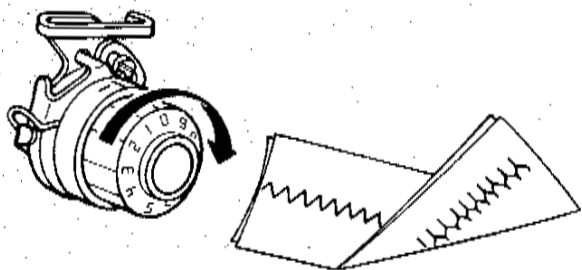

**Too Little Tension**

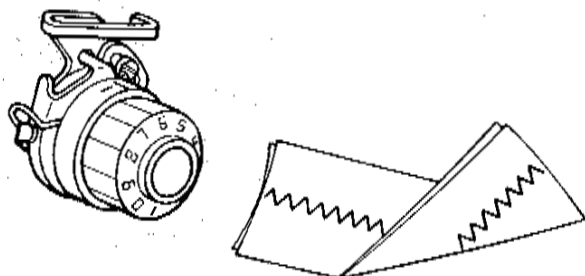

**Correct Tension**

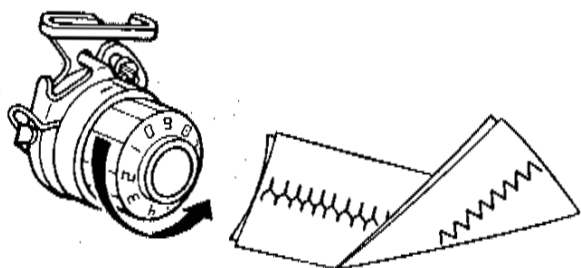

**Too Much Tension**

### ADJUSTING NEEDLE THREAD TENSION

Zig-zag stitching requires less needle thread tension than straight stitching.

Make a test sample with the fabric and thread you plan to use so that you can adjust the tension properly. The stitches should lie flat against the fabric without causing the fabric to pucker.

If the stitches are not flat and the fabric is puckered, lower the needle thread tension by turning the dial to a lower number.

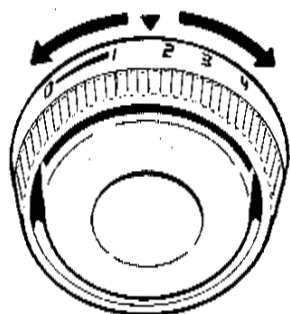

### ADJUSTING STITCH LENGTH

Any stitch length setting from 1 to 4 will give you an open zig-zag stitch.

The higher the number, the more open, or farther apart your stitches will be.

The area between 0 and 1 on the dial, is used for the adjustment of zig-zag satin stitching, a series of closely spaced plain zig-zag stitches that form a smooth, satin-like surface. (Refer to page 21 for information on satin stitching).

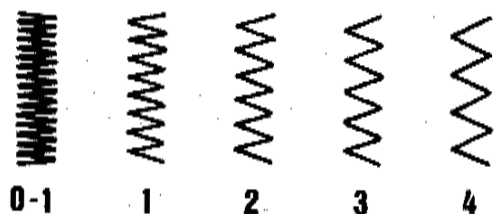

**Stitch Length Setting**



### ADJUSTING PRESSER FOOT PRESSURE

See page 15 under « Straight Stitching ».

## ***satin stitching***

When you wish to produce a satin stitch make a test sample first so you can adjust stitch length and thread tension properly. Soft fabric may require a backing to ensure a firm stitch. Crisp organdy, lawn or a fusible interfacing are suitable for this purpose.

### **Accessory and Selector Settings**

---

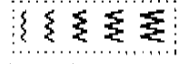
- Pattern Group Selector: /
  - Needle Position: 
  - Stitch Width: 
  - Stitch Length: 0 to 1
  - General Purpose Needle Plate
  - Special Purpose Foot
- 

### **ADJUSTING STITCH LENGTH**

- Turn stitch length selector dial to 1.
- Run the machine at a slow speed and gradually turn stitch length dial clockwise until stitches are closely spaced and form a smooth surface.

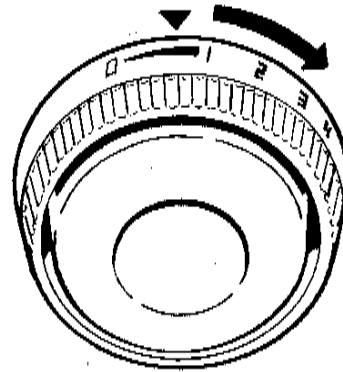
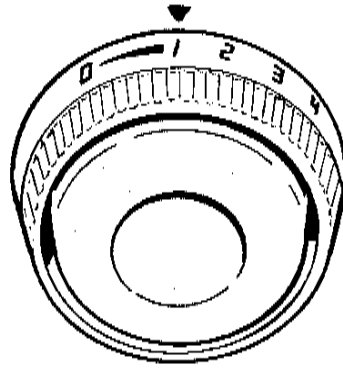

### **ADJUSTING NEEDLE THREAD TENSION**

Satin stitching requires less tension than straight stitching or open zig-zag stitching. Furthermore, the wider the stitch, the lighter the tension on the thread must be. Notice the stitching on your sample. If the fabric is puckered, lower the needle thread tension by turning the tension dial to a lower number.

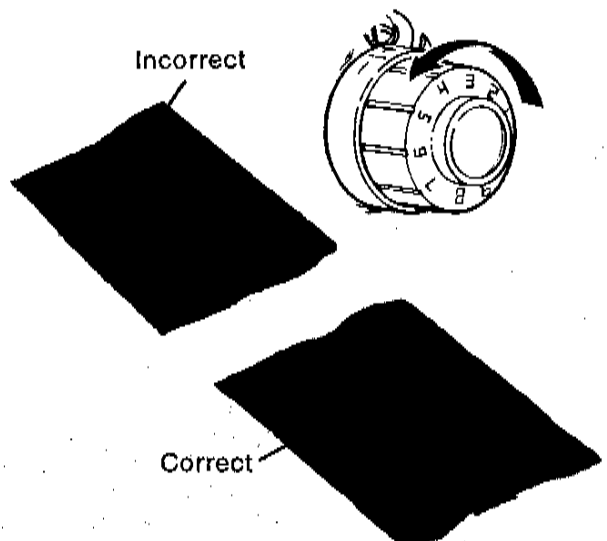



## applications

### APPLIQUÉ

Appliqué adds beauty and interest to clothing and household linens. You can create your own design, trace a simple cutline from a colouring book, or use a motif cut from a printed fabric. Fabrics of similar or different textures combine equally well.

A closely spaced plain zig-zag stitch is used for appliqué work. Although you may vary stitch width to accommodate fabric weave and texture, never allow the stitch to be too wide. Make a test sample to help you decide which of the following methods is best for your fabric and design.

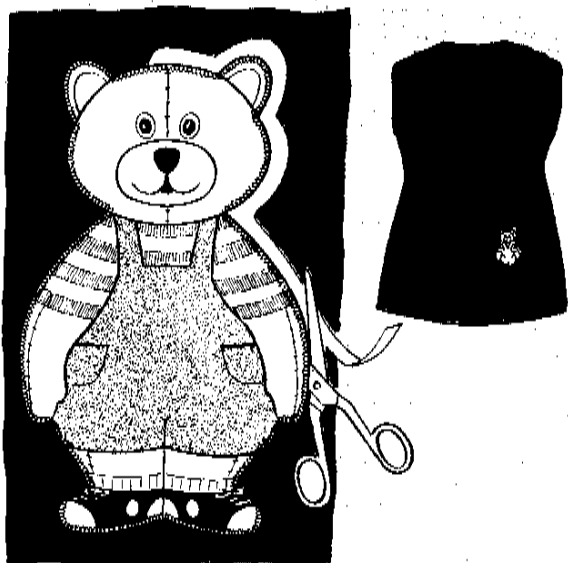

Method 1

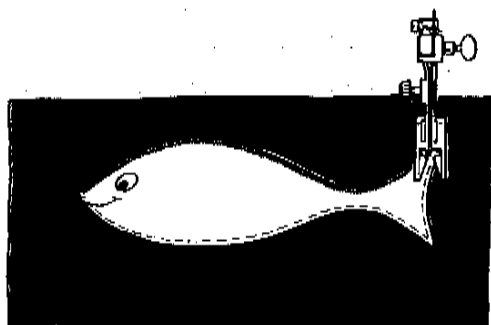
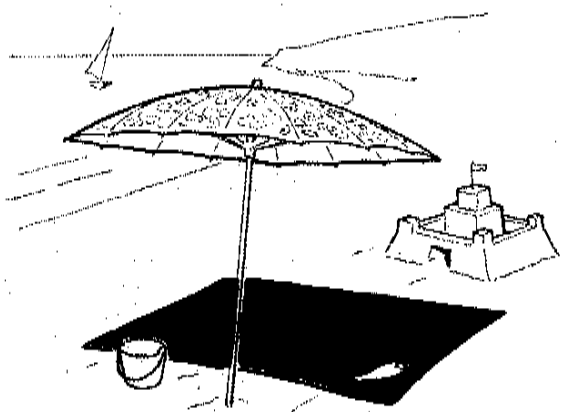

Method 2

- 
- Pattern Group Selector: /
  - Needle Position: 
  - Stitch Width: To suit fabric
  - Stitch Length: Between 0 and 1
  - General Purpose Needle Plate
  - Special Purpose Foot
- 

#### Preparation

- Baste appliqué design to fabric and outline the design with a short straight stitch.
- Remove basting and press.

#### Method 1 - Trimming after Stitching

- Set machine as code recommends.
- Outline the entire design with appliqué stitching.
- Cut away the fabric or the outer edges of the stitching with embroidery scissors.

#### Method 2 - Stitching after Trimming

- Trim outside fabric edges close to straight stitch outline of design.
- Set machine as code recommends.
- Overedge the design with appliqué stitching. This step will produce a smooth, lustrous finish that requires no additional trimming.

## LINGERIE SEAMS

To make a lingerie seam durable and flexible use the plain zig-zag stitch at a narrow width setting. This seam treatment is particularly suitable for bias seams. When seaming nylon tricot insert a 2045 needle in the machine before you begin to sew.

- Straight stitch the seam line on wrong side of fabric.
- Press both seam allowances in the same direction.
- From the right side, topstitch with narrow zig-zag stitching, letting the needle alternately enter the seam line and seam thickness.  
(Stitch width narrow; stitch length 1 to 1.5).

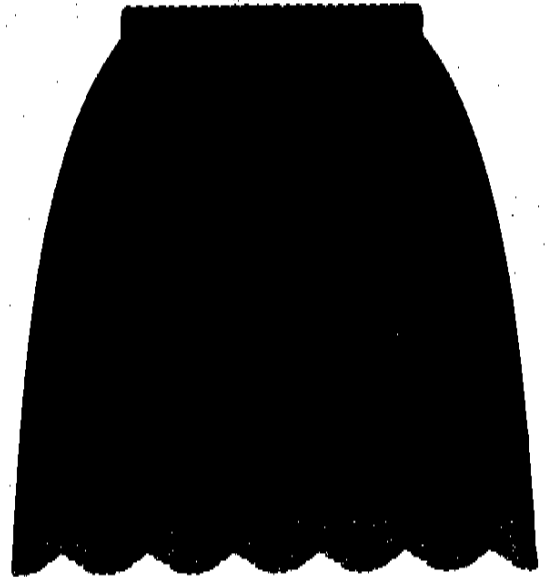

## ZIG-ZAG SEAM FINISHES

Seam edges support the garment and should be given a durable finish if the fabric is likely to ravel. There are two methods of finishing seams in such fabrics: trimming seam edge or overedging. Make a test sample to determine which method best suits your fabric.

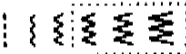
- 
- Pattern Group Selector: /
  - Needle Position: 
  - Stitch Width: 
  - Stitch Length: 1 to 3 to suit fabric
  - General Purpose Needle Plate
  - General Purpose Foot
- 

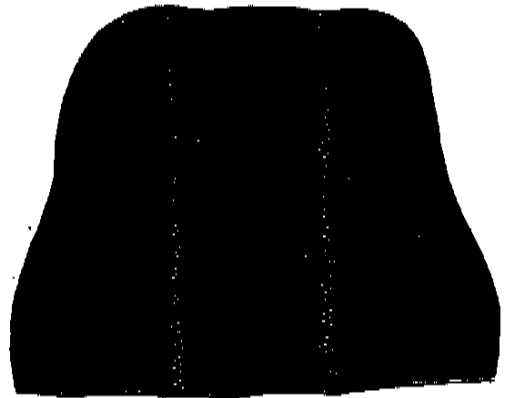

Method 1

### Method 1 - Trimmed Seam Finish

- Adjust stitch width and length to give you the most «open» stitch that will secure the fabric edge; avoid harsh over stitching.
- Stitch near the edge of seam allowance, and trim seam edges evenly after stitching.

### Method 2 - Overedged Seam Finish

- Adjust needle thread tension, stitch width, and stitch length to suit fabric.
- Trim seam edges evenly.
- Place trimmed seam under the foot and overedge the seam allowance as illustrated.

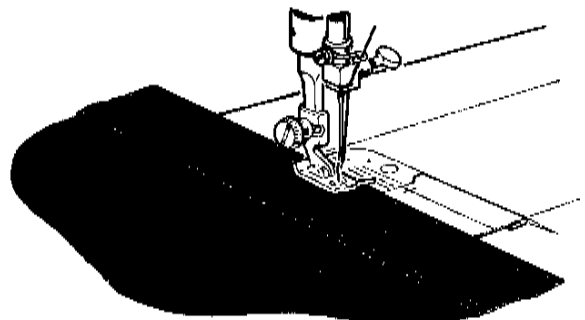

Method 2

# Chapter 5. Machine Stitch Patterns

## Setting selectors

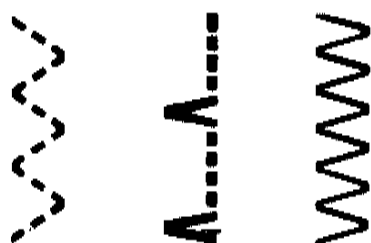
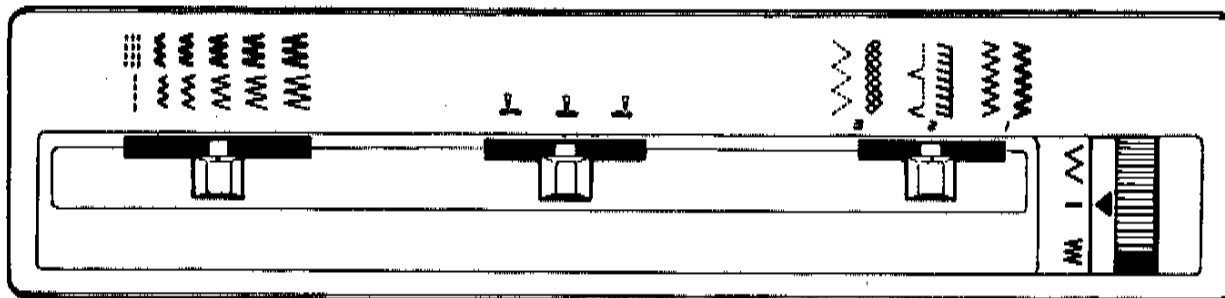

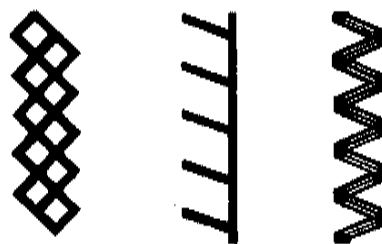

Decorative Stitch Patterns



Stretch Stitch Patterns

In addition to straight stitch and zig-zag stitch, your machine can produce a variety of stitch patterns. There are two types of stitch patterns built into your machine:

- **decorative stitch patterns**, illustrated above, are produced by side-to-side movement of the needle,
- **stretch stitch patterns**, illustrated above, are produced by both the side-to-side movement of the needle and the back-and-forth movement of the feed.

The straight stretch symbol  is positioned at left side of control panel above the straight stitch symbol .

Refer to chart on page 28 for further information on machine setting and applications for the stitch patterns on your machine.

## SELECTING A PATTERN GROUP

*Before moving pattern group selector, make sure needle is above fabric.*

When you move the pattern group selector, one of three different groups of stitch pattern is available to you.

Slide stitch width selector to **1**, then set the pattern group selector as required, under the number of the desired group of two stitches.

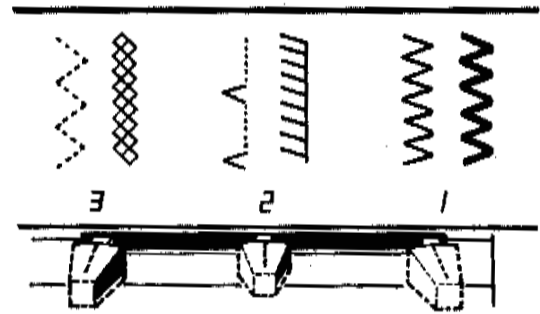

## ADJUSTING WIDTH OF THE DESIGN

*Before moving stitch width selector, always raise needle above fabric.*

To produce a stitch pattern, the stitch width selector must be moved from **1** toward the right. The further you move the selector lever toward the right, the wider your stitch will be.

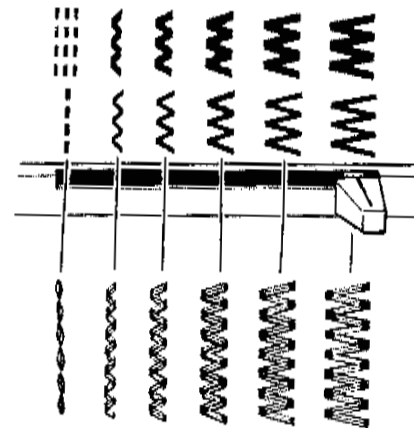

Stitch Width Selector

## ADJUSTING STITCH PLACEMENT

*Before moving needle position selector, make sure needle is above fabric.*

All stitch patterns can be sewn in either left **1**, centre **2**, or right **3** needle position. Selector setting centre **2** is used most often. A **1** left or **3** right setting is used to place narrow stitch patterns to the left or right of the centre in decorative work.

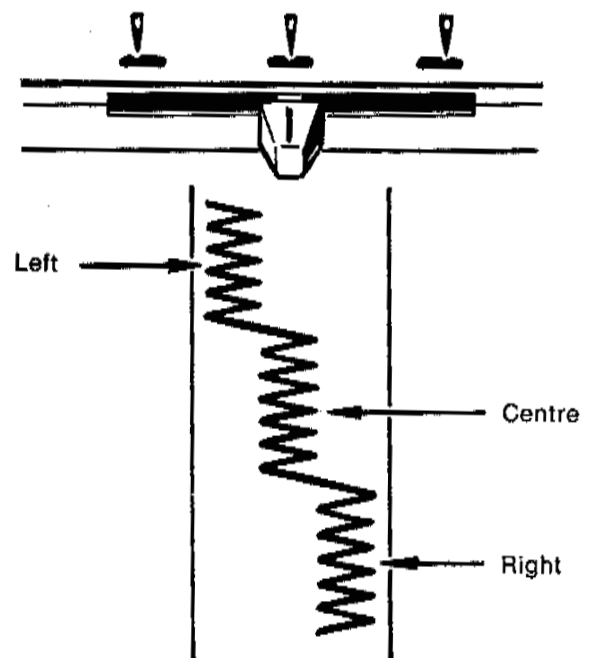

## ADJUSTING STITCH LENGTH

When you are preparing to do pattern stitching, make a test sample with the fabric and thread you plan to use so that you can adjust the stitch length correctly.

Any stitch length setting from 1 to 4 will give you an open stitch pattern of whichever decorative stitch pattern you select. The higher the number, the more open, or farther apart, your stitch will be. The area between 0 and 1 of the selector is used for the fine adjustment of satin stitching (see page 21).

**For stretch stitch patterns,** stitch length is controlled with a single setting of the stitch length selector. Simply rotate it until the coloured bar ■ is under the ▼ symbol above the dial.

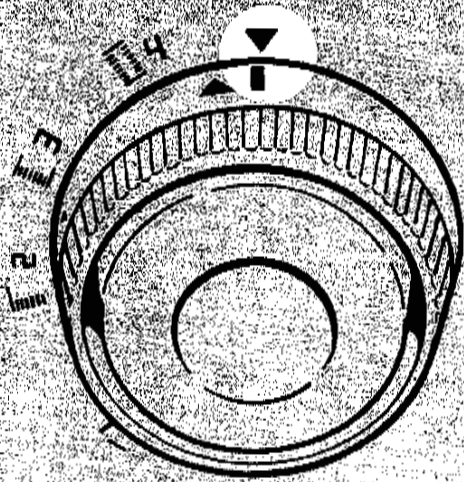

Setting for Stretch Stitch Pattern

## ADJUSTING STITCH BALANCE

When you are using stretch stitch patterns, you may need to adjust the stitch balance dial in order to correct the appearance of the stitch.

Before you move the dial from its neutral position (◀ symbol on dial aligned with line — on panel), make a test sample. If adjustment is required stitch slowly and move the dial as illustrated.

- Turn dial **down** to bring stitches of the patterns together (ill. **A**).
- Turn dial **up** to separate stitches of the patterns (ill. **B**).

Always return the dial to its neutral position after sewing stretch stitch patterns.

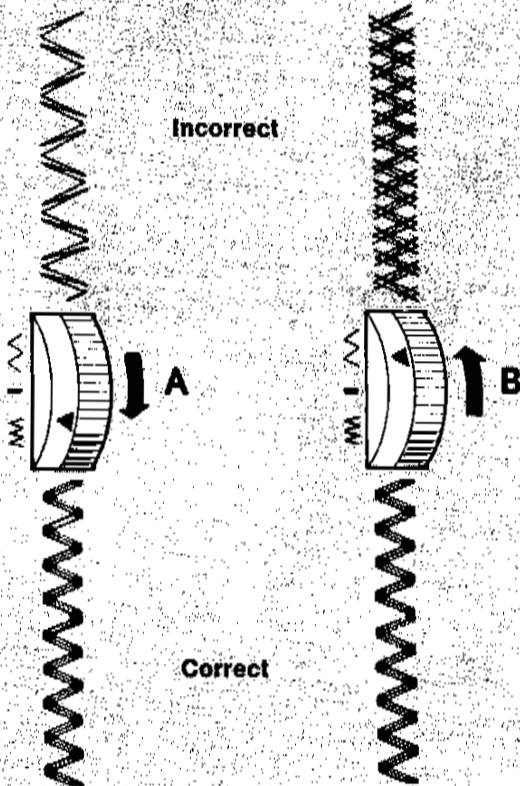

## adjusting stitches to suit stretch fabrics

### GUIDING AND SUPPORTING FABRIC

Most fabrics of stretch or knit construction need only to be guided in front of the presser foot when you use one of the stretch stitches. Some fabrics — nylon tricot and elasticized fabrics, for example — do require support while being stitched.

- For nylon tricot and similar synthetic knits, apply **gentle** tension by holding the seam in front and back of the presser foot as you sew (illustration **A**).
- For elasticized fabric, stretch lace, and knits with an unusual amount of elasticity, apply **firm** tension in front and back of the presser foot to stretch the seam as the stitches are being placed (illustration **B**).

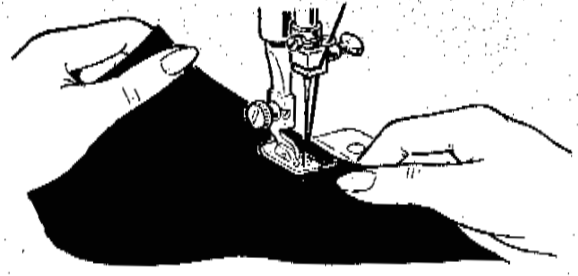

**A**

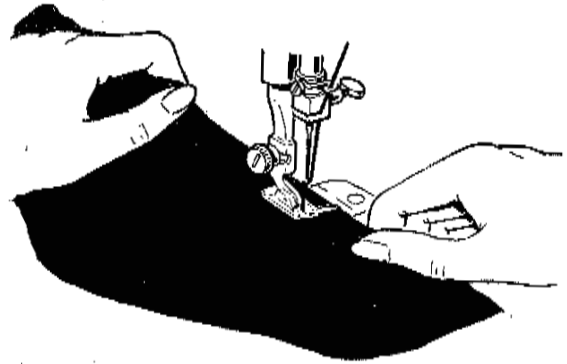

**B**

**CAUTION:** Do not pull the fabric while you are stitching as this may deflect the needle, causing it to break.

### ADJUSTING PRESSURE WHEN SEWING KNIT AND STRETCH FABRIC











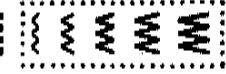

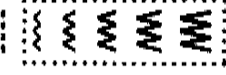

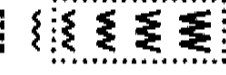
Some knit and stretch fabrics, because of their structure, require either more or less than normal (**NORM**) presser bar pressure to feed smoothly and evenly.

- For thick, soft or very stretchy knits, decrease pressure by turning dial from **NORM** toward #
- For nylon tricot, ciré and similar hard surface synthetic knits, increase pressure by turning dial from **NORM** toward **MAX**.

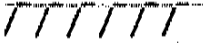

## STITCH PATTERN CHART

The table below will help you to select the correct pattern for your fabric and sewing job.

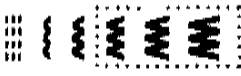
 <b>Zig-Zag</b>	/	.5 - 4		Used for general purpose stretch sewing, bar tacks, finishing seams, embroidery and appliqué.
 <b>Blindstitch</b>	2	1 - 2.5		For finishing hems and making ladder seams.
 <b>Multi Stitch Zig-Zag</b>	E	.5 - 1		Lets you mend, join and reinforce without bulk. Ideal for bar tacking.
 <b>Straight Stretch<sup>Δ</sup></b>	Any setting	 (Coloured Bar)	 only	Ideal for plain seams that stretch and for repairing and reinforcing seams.
 <b>Ric-Rac Sttitch<sup>Δ</sup></b>	/	 (Coloured Bar)		For heavy-duty general purpose sewing.
 <b>Slant Overedge<sup>Δ</sup></b>	2	 (Coloured Bar)		Sweater and swimsuit construction. - Overcast seams in bulky knits and stretch terry cloth.
 <b>Honeycomb<sup>Δ</sup></b>	E	 (Coloured Bar)		Useful for mending, overcasting and attaching elastic and stretch lace.

<sup>Δ</sup> SLOW speed setting is recommended for sewing Stretch Stitch patterns and a lighter-than-normal pressure dial setting may be needed for some fabrics. This stitch is designed for strength and permanence and cannot readily be ripped out, without risk of fabric damage.

## applications

### BLINDSTITCH

The blindstitch has many practical and functional uses. Its most common use provides a durable hem finish. However, the creative ways that one might apply this stitch are unending.

#### Blindstitch Hems

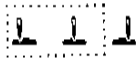
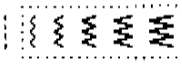
- Pattern Group Selector: 
- Needle Position: 
- Stitch Width: 
- Stitch Length: 1 to 2.5
- General Purpose Needle Plate
- General Purpose Foot
- Blindstitch Hem Guide

1. Raise foot, loosen screw, and slip blindstitch hem guide from the front between the screw and the shank of the foot. Make sure the underside of the guide clears the slide plate and the front of the foot. Tighten screw with coin.
2. Prepare hem in the usual way. It is advisable to baste the hem. Place the basting at least 1.3 cm ( $\frac{1}{2}$  inch) below the edge of the hem allowance to avoid catching the flange of the guide as you stitch.
3. With the wrong side of the work uppermost, turn the hem under, creating a soft fold from the top edge of the hem.
4. Position the hem under the foot with the soft fold resting against the wall of the guide. Make sure the flange of the guide is between the soft fold and top of hem, as shown.
5. Lower the foot and stitch so that the straight stitches fall on the hem allowance and the zig-zag stitches pierce the soft fold of the work. Adjust stitch width if necessary. While stitching, guide the hem edge in a straight line and feed the soft fold evenly against the wall of the guide.

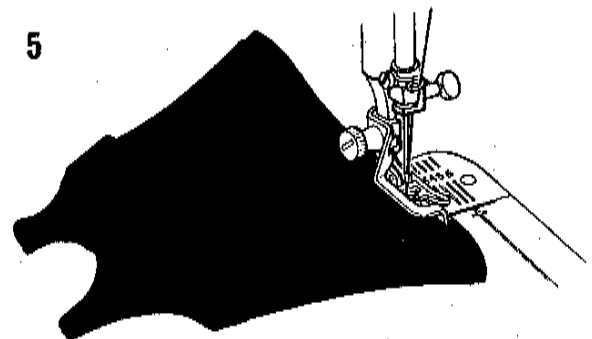
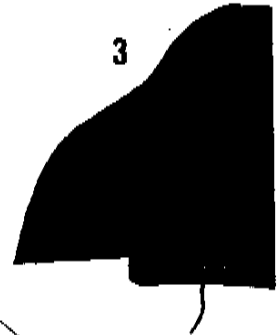
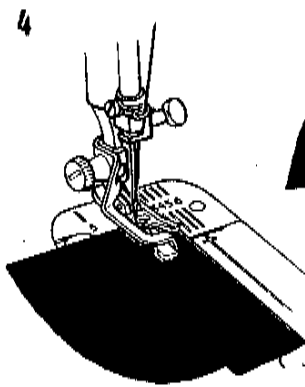
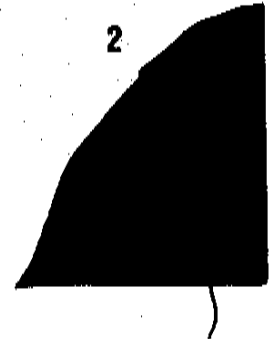
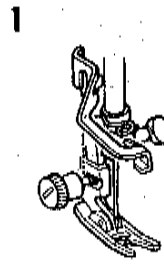





## MULTI-STITCH ZIG-ZAG

The multi-stitch zig-zag is an extremely versatile stitch. Use it to mend, join or reinforce without bulk. With this stitch you may attach elastic and stretch lace, construct lingerie and swimsuits and finish seams. There are many other useful applications for the multi-stitch zig-zag.

### Bar Tacks

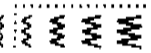
- Pattern Group Selector: 
- Needle Position: 
- Stitch Width: 
- Stitch Length: 0
- General Purpose Needle Plate
- General Purpose Foot

Make a test sample, using scraps of your material, and duplicating all garment thickness.

1. Mark position for the finished end of belt loop on the fabric.
  - Place belt loop, wrong side up, straight stitch with cut end 3 mm (1/8 inch) from edge of garment; do not stitch beyond edges of the belt loop. Trim the end close to the stitching and press.
2. Fold belt loop back on the stitching line and press.
  - Set your machine according to the code above.
  - Stitch 3 mm (1/8 inch) from the fold using the multi-stitch zig-zag stitch.
3. Fold over second part and bar tack.

### Mending a Tear



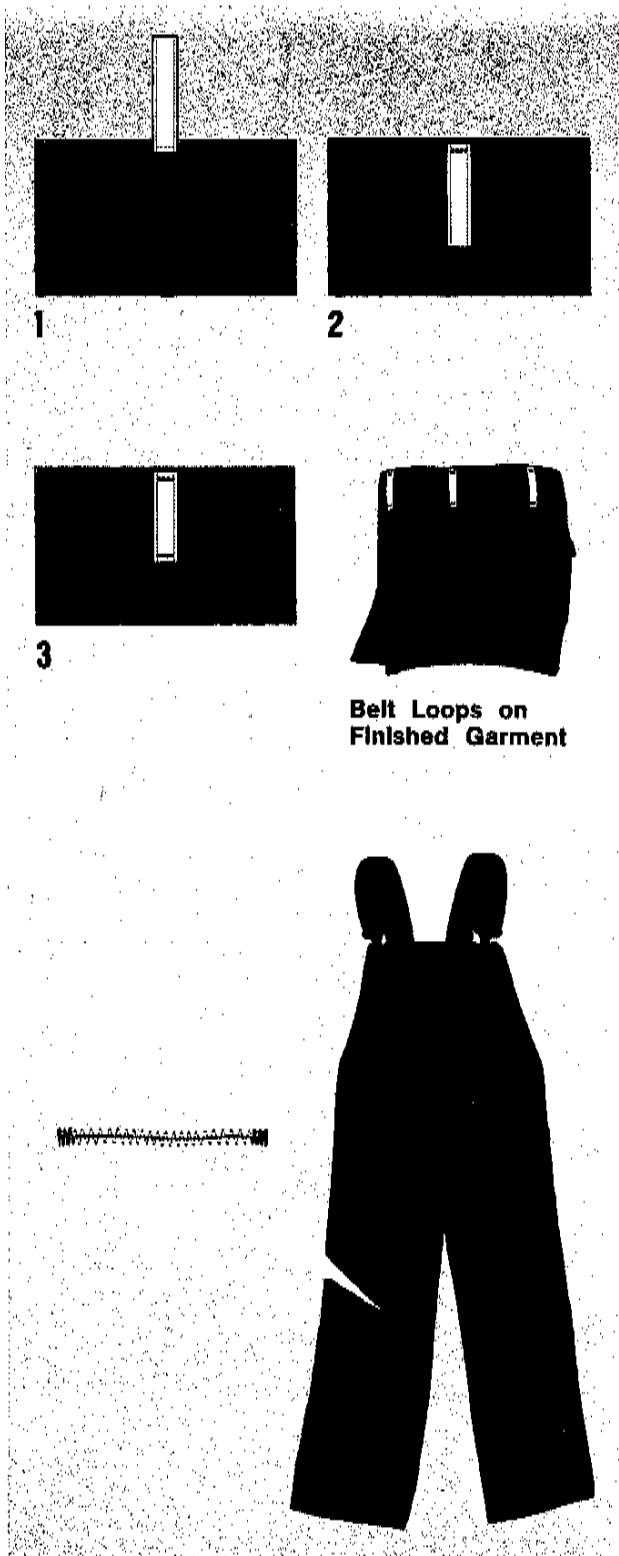

- Trim ragged edges.
- Place underlay on the wrong side of tear for reinforcement. (Do not baste or pin the underlay, since you will be bringing the edges together in the next step).
- Stitch on the right side, bringing the edges of the tear together. Shorten stitch length at ends and corners to give extra strength.
- Trim underlay.



## HONEYCOMB STITCH

The honeycomb stitch is ideal for smocking and it is useful for mending, overcasting and attaching lingerie elastic, stretch lace and blanket binding. Use this versatile stitch to create decorative designs on fabrics that stretch.

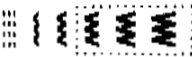
### Replacing Lingerie Elastic

- Pattern Group Selector: 
- Needle Position: 
- Stitch Width: 
- Stitch Length:  (Coloured Bar)
- Stitch Balance: To suit application or fabric
- General Purpose Needle Plate
- General Purpose Foot

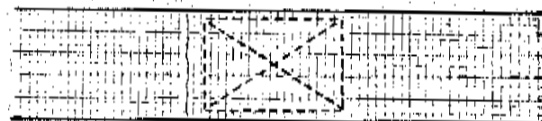

Joining Elastic

We recommend the needle style 2045 when sewing on regular elastic.

- Fit elastic for desired snugness at waistline, allowing 2.5 cm (1 inch) for joining. Lap ends to form a band and straight stitch together as shown using a ball point needle.
- Divide elastic band into four equal segments and mark with pins. Do the same to the garment. Then pin together at corresponding points, pinning elastic over right side of fabric, top edges even.
- Sew a few straight stitches to anchor elastic to fabric.
- Select honeycomb, plain zig-zag, and multi-stitch zig-zag are also effective for replacing lingerie elastic.
- Then hold elastic and garment edge taut as you stitch so that it will remain stretchable after stitching is completed.

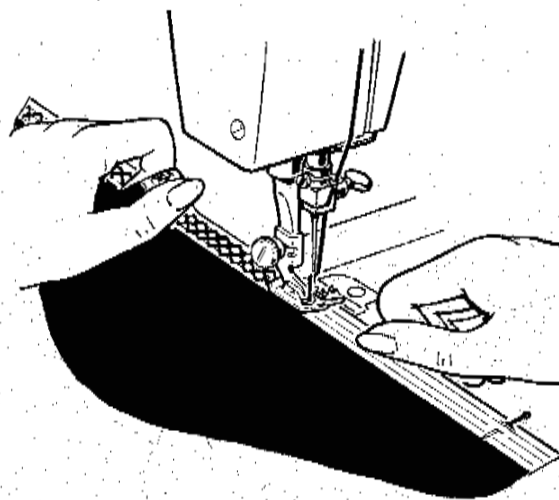

Replacing Elastic

**CAUTION:** Do not pull the fabric while you are stitching as this may deflect the needle, causing it to break.

# Chapter 6. Buttonholes and Buttons

## **buttonholes**

- 
- Pattern Group Selector: /
  - Stitch Balance Dial: Neutral position
  - Buttonhole Foot
- 

Always make a test buttonhole on a sample in your fabric. Be sure to duplicate thickness of garment and include interfacing.

If the two lines of stitching in your sample are of unequal density refer to the next page.

Place work under buttonhole foot, align centre marking of buttonhole **A** with red line on foot, and align end marking of buttonhole **B** with horizontal line on foot. Do not lower the needle.

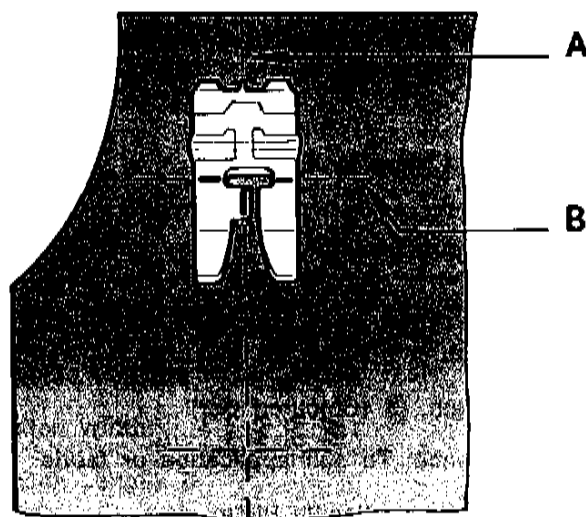

### **FOUR-STEP BUTTONHOLING**

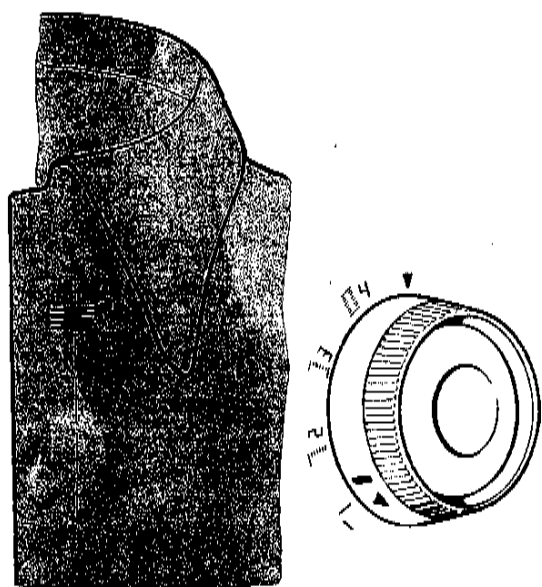

#### **Step 1: Bar Tack**

Turn buttonhole dial *clockwise* to step **1**. Position needle in fabric at point **A**. Lower the foot and stitch the first bar tack taking at least four stitches ending at point **B**.

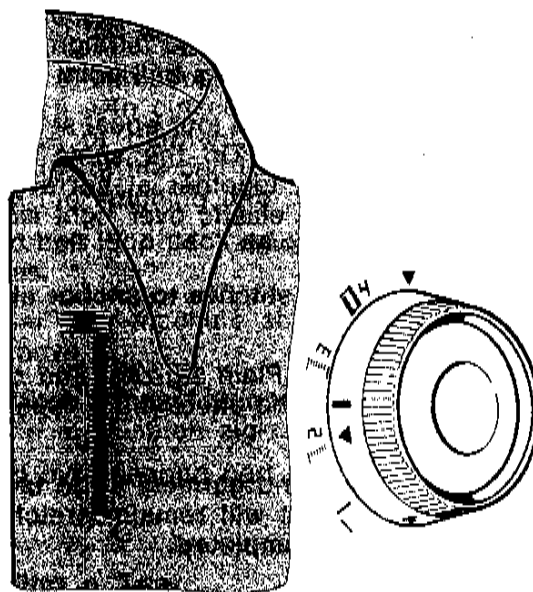

#### **Step 2: Side Stitching**

Raise needle above fabric by turning hand wheel *toward you*. Turn buttonhole dial *clockwise* to step **2**. Stitch to the end of buttonhole at point **C**.

## FOUR-STEP BUTTONHOLING (Cont'd.)

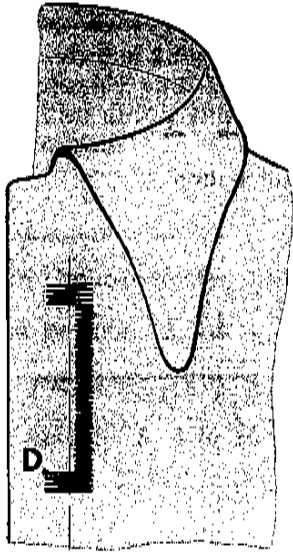

**Step 3: Bar Tack**

Raise the needle above the fabric.  
Turn buttonhole dial *clockwise* to step 3. Take at least four stitches ending at point D.

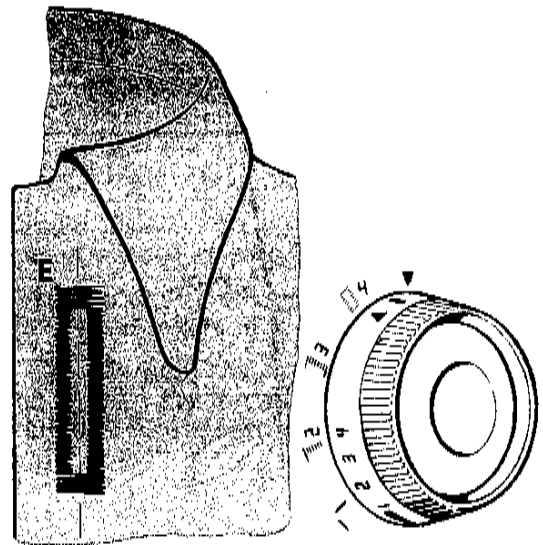

**Step 4: Side Stitching**

Raise the needle above the fabric.  
Turn buttonhole dial *clockwise* to step 4. Stitch until the side stitching meets the bar tack at point E.

## CHANGING STITCH DENSITY

Stitch density on left and right sides of the buttonhole may be balanced by using the stitch balance dial. Use the stitch balance dial to obtain similar stitch appearance on either side of the buttonhole.

To change the density on either side of the buttonhole follow the procedure below. Return the balance dial to its neutral position after buttonhole sewing is completed.

IF



Stitches on the *right* side are too far apart

THEN DO THIS

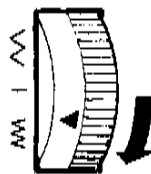

RESULT



Similar stitch appearance on either side of the buttonhole

IF



Stitches on the *left* side are too far apart

THEN DO THIS

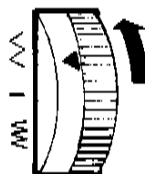



RESULT



Similar stitch appearance on either side of the buttonhole

## buttons

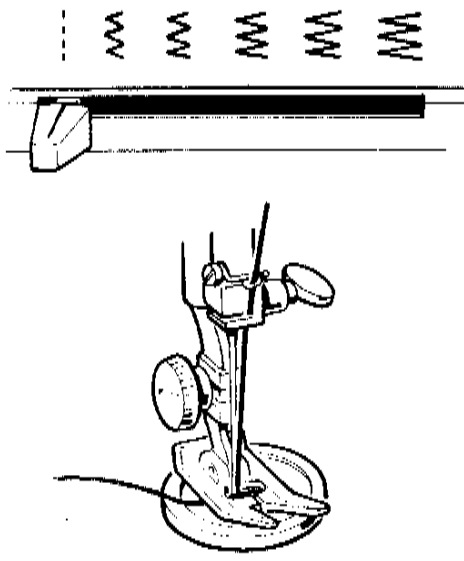
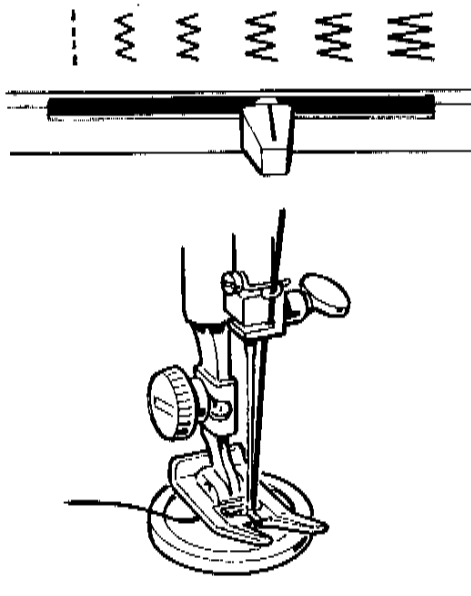
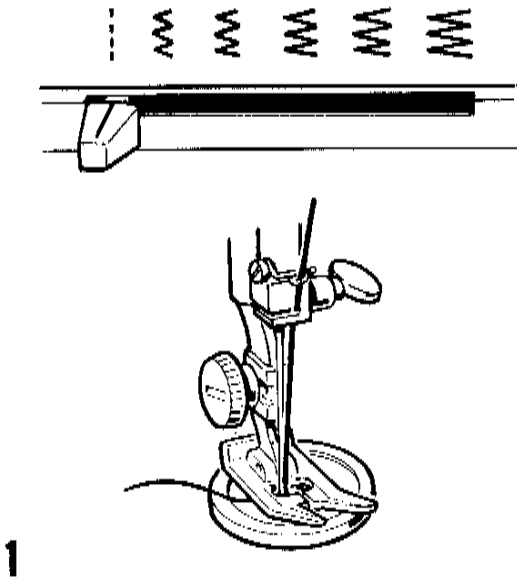

---

- Pattern Group Selector: 1
  - Needle Position:   
  - Stitch Width: To suit button
  - Stitch Length: 0
  - Snap-in Feed Cover
  - General Purpose Foot
- 



### ATTACHING A BUTTON

Flat buttons can be sewn on by machine using the zig-zag stitch.

- Attach snap-in feed cover to general purpose needle plate.
1. Set stitch width selector at .
    - Set needle position at left .
    - Place button positioned on fabric under foot and lower needle into centre of left hole.
    - Lower presser foot.
    - Turn hand wheel *toward you* until the needle rises out of button hole and is just above the presser foot.
  2. Set stitch width selector to a medium width zig-zag setting.
    - Continue turning hand wheel until the needle is above right hole, adjust stitch width, as necessary, until needle enters the centre of the right hole.
    - Take six or more zig-zag stitches and finish with the needle on the left.
  3. Move stitch width selector to  and take a few stitches to fasten threads.
    - Pull thread ends through to back of garment knot close to fabric and snip off loose ends of thread.

# Chapter 7. Twin - Needle Stitching

The twin-needle simultaneously produces two parallel, closely spaced lines of pattern stitching. You can stitch with either one or two colours of thread.

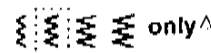
- Pattern Group Selector: Stitch desired
- Needle Position:  only
- Stitch Width:  only<sup>Δ</sup>
- Stitch Length: .5 - 4 to suit fabric
- General Purpose Needle Plate
- General Purpose Foot or Special Purpose Foot

## Procedure

- Insert twin-needle.
- Thread as for single-needle stitching, and through *right* eye of needle.
- Attach detachable spool pin, with felt, on bobbin winder spindle.
- Place spool of thread on detachable spool pin and thread machine in usual way.
- Thread through remaining points, making certain to *omit the thread guide above the needle* and pass thread through *left* eye of needle.

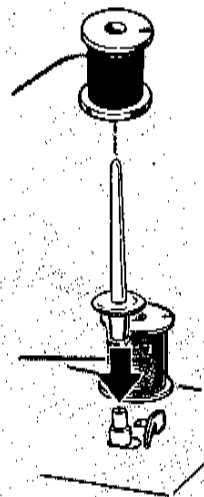
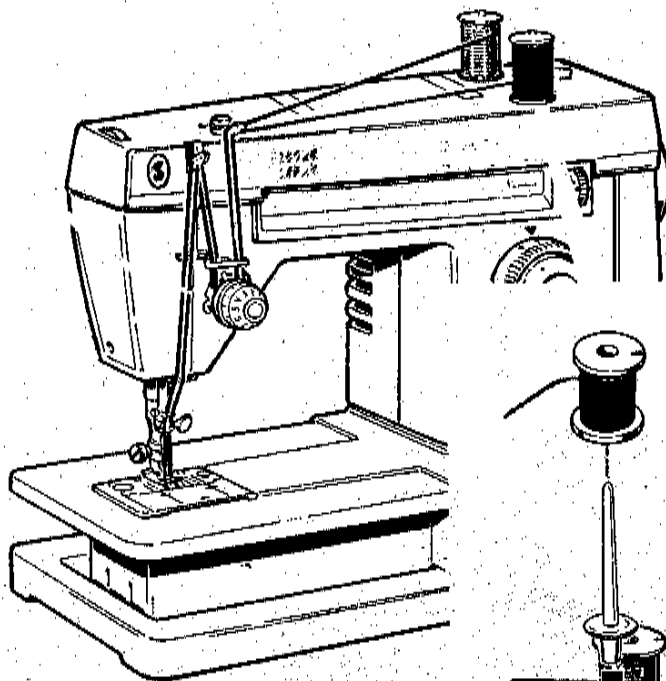
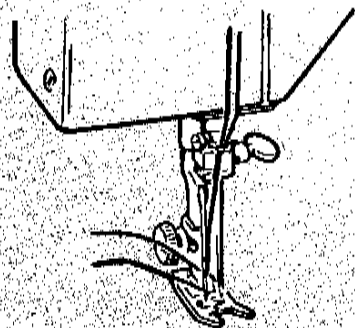
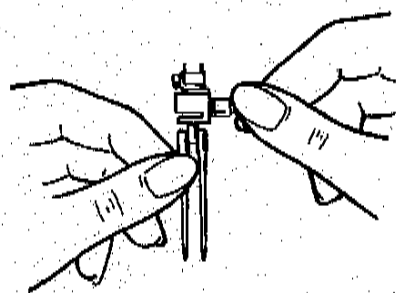
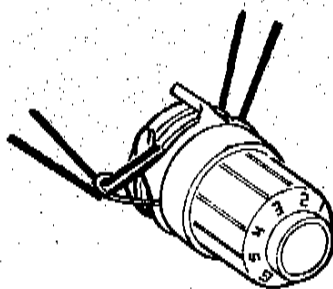
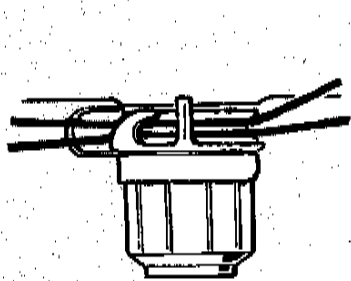

Δ CAUTION: Do not use a stitch width greater than what is recommended. A wider stitch will result in needle breakage.

# Chapter 8. Free-Arm Sewing

Fabric handling, when sewing tubular and hard to reach garment areas, is simplified when you convert your sewing machine to free-arm sewing.

- To convert machine to free-arm sewing, simply lift the extension bed up and off the machine as illustrated.
- To convert machine back for flat bed sewing, simply slide extension bed onto the base of the machine and snap into place.

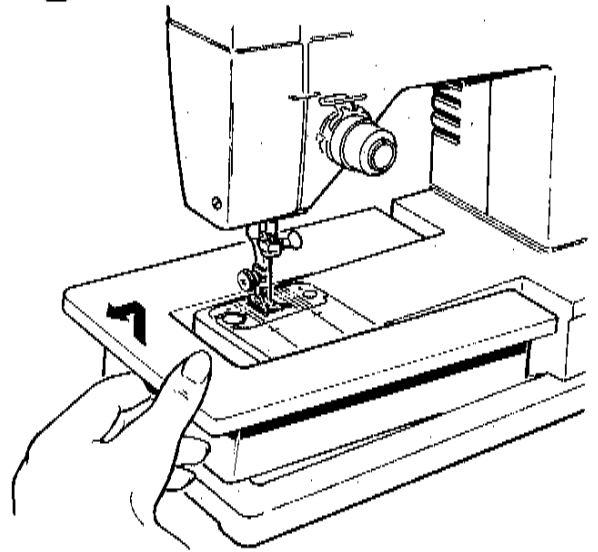

## applications

A few of the sewing jobs for which you will find the free-arm particularly useful are shown below.

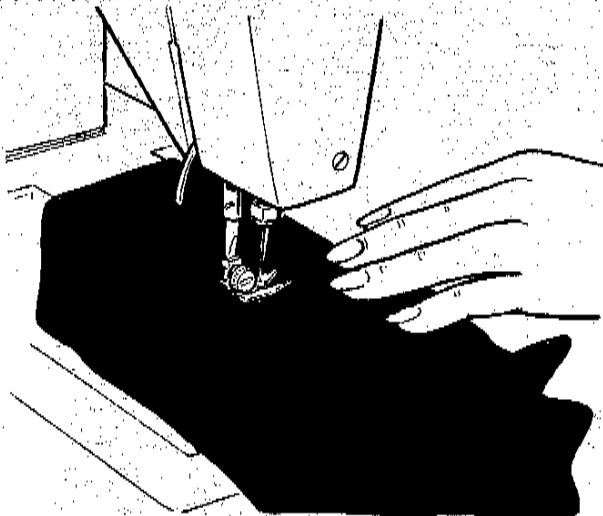

**Sleeves**

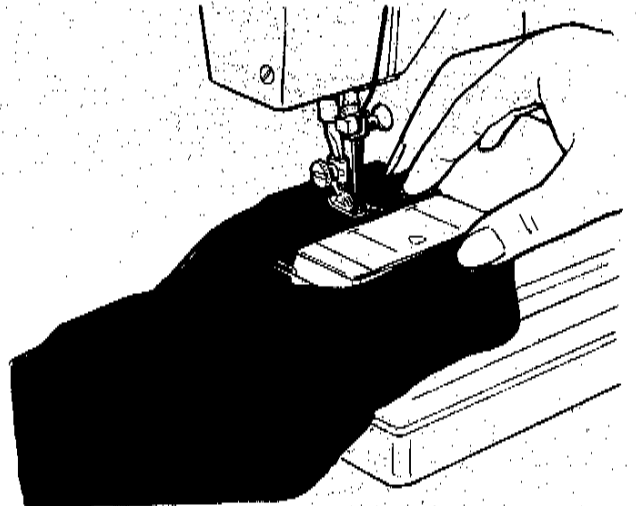

**Buttons**

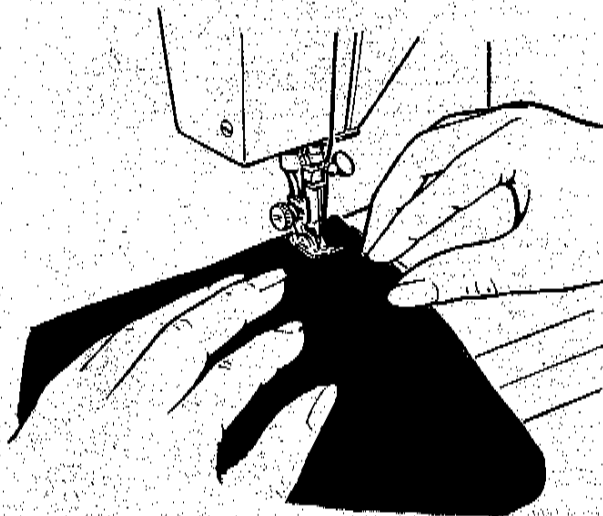

**Bar Tacks**

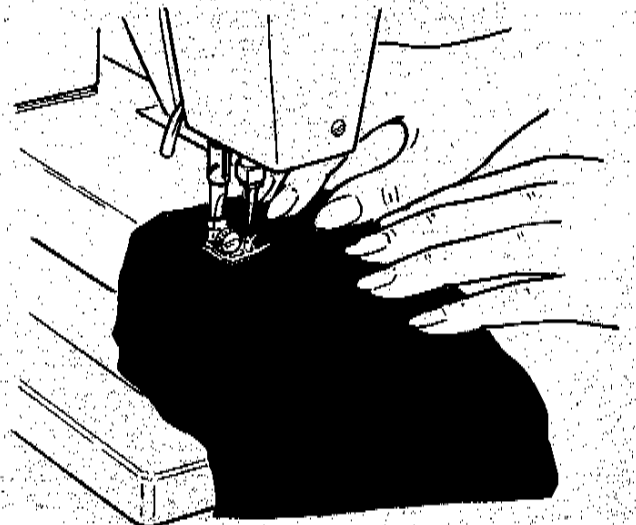

**Edge Finishes**

# Chapter 9. Performance Checklist

Whenever sewing difficulty is encountered, review the sections of the instruction book that explain the operation you are performing to make sure you are using the machine correctly. If the problem still exists, the following checklist may help you to correct it.

If you still have difficulties, call your nearest authorized Dealer.

## What To Do If:

### Needle Breaks

Refer to Page:

*Make sure...*

- Needle is fully inserted into needle clamp . . . . . 4
- Needle is not being pulled to one side as fabric is removed from the machine . . . . . 17
- Presser foot or accessory is securely fastened to presser bar . . . . . 4
- Fabric is not being pulled while sewing causing needle to hit needle plate . . . . . 27

### Thread Breaks

*Make sure...*

- Machine is properly threaded . . . . . 13
- Needle is straight and sharp . . . . . 10
- Needle thread tension is not too tight . . . . . 16, 20, 21
- Thread is unwinding freely from spool . . . . . 11
- Bobbin case area is free of lint and loose thread ends . . . . . 38

### Machine Is Noisy or Sluggish

*Make sure...*

- Bobbin case and feed area are free of lint and loose thread ends . . . . . 38

### Fabric Does Not Move Properly

*Make sure...*

- Presser foot or accessory is correctly attached to machine . . . . . 4
- Stitch length dial is correctly set . . . . . 16, 20, 26
- Lint has not accumulated around feed . . . . . 38

### Skipped Stitches

*Make sure...*

- Needle is straight and sharp . . . . . 10
- Needle is correct style for machine and size for thread . . . . . 8, 9
- Machine is correctly threaded . . . . . 13
- Needle is securely fastened to needle bar . . . . . 4

### Fabric Puckers

*Make sure...*

- Needle thread tension is not too tight . . . . . 16, 20, 21

### Needle thread breaks while winding bobbin

*Make sure...*

- Machine is correctly threaded . . . . . 13
- Thread is unwinding freely from spool . . . . . 11

### Thread does not wind onto bobbin

*Make sure...*

- Bobbin winder spindle is pushed to right . . . . . 11



# Chapter 10. Caring For Your Machine

## CLEANING YOUR MACHINE

**CAUTION:** Before cleaning your machine, disconnect power line plug from your socket outlet.

With a soft cloth or lint brush, clean all points indicated by arrows, especially the bobbin case area and feed. Also, clean exposed parts. If necessary a mild solution of soap and water may be used to remove stubborn stains. No other cleaning liquid or powder should be used.

Periodically apply a drop of oil only to the areas indicated after cleaning.

### CAUTION

Do not attempt to adjust the motor belt drive. Refer to your nearest Singer service centre should any adjustments be required.

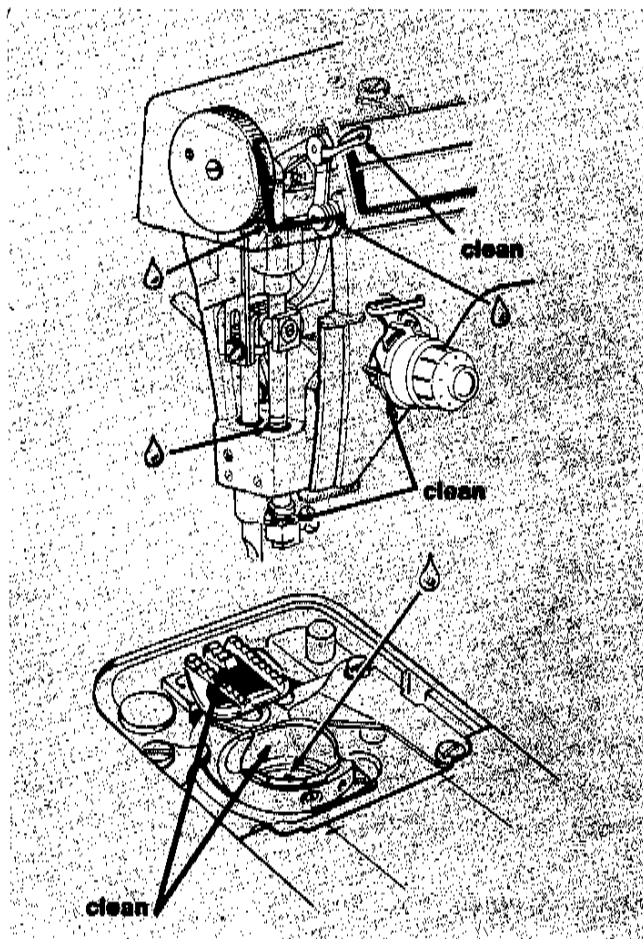

## REMOVING BOBBIN CASE

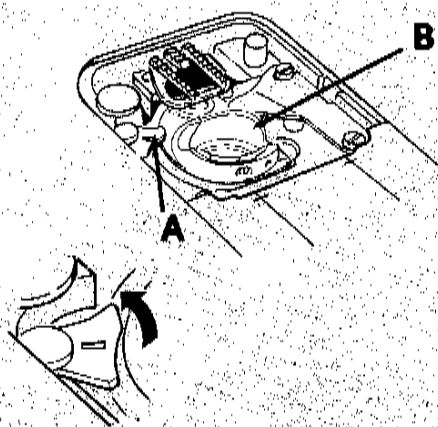

Raise needle, open slide plate, remove needle plate and lift out bobbin.  
Turn bobbin case holder **A** to back as far as it will go.  
Lift out bobbin case **B**.

## REPLACING BOBBIN CASE

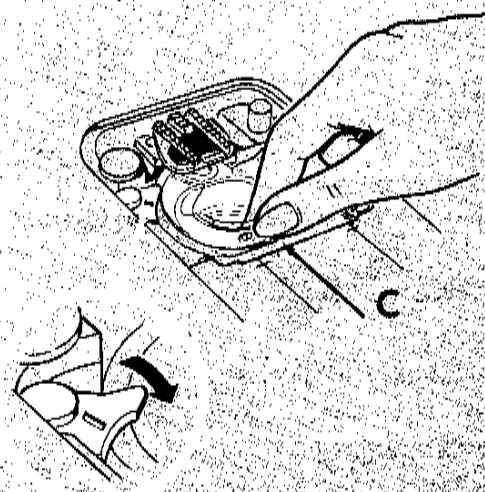

Insert bobbin case with a back and forth motion, so that front of the case is under the position plate **C**. Turn holder all the way forward to lock bobbin case.  
Replace needle plate and close slide plate.

## REMOVING FACE PLATE

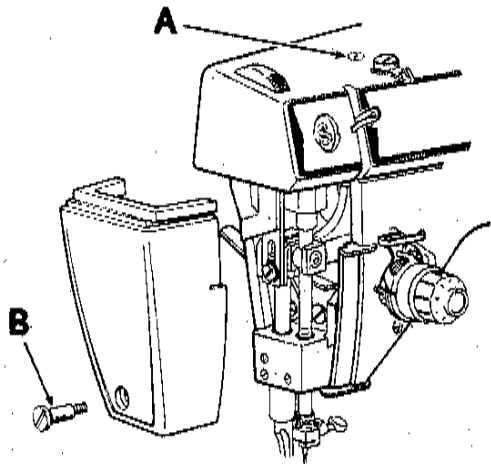

Loosen screw **A** (do not remove). Loosen face plate screw **B** then remove face plate by drawing it toward you. Replace face plate by sliding top edge of plate under edge of arm top cover. Tighten screws **B** and **A**.

## REPLACING SLIDE PLATE

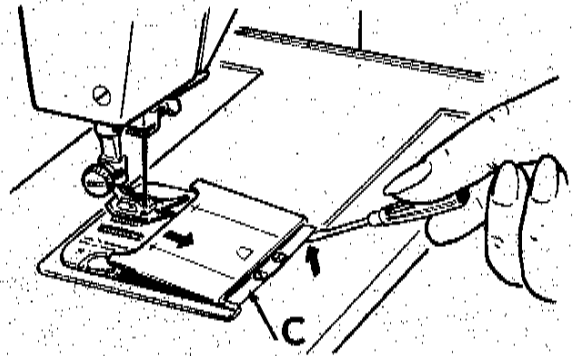

Place slide plate in slide way with the front edge close to, but not covering, the retaining spring **C**. With a small screwdriver, lift each end of the spring into each of the side grooves on the under side of the slide plate. Draw the slide plate gently toward you to fully engage the spring. Close slide plate.

## CHANGING THE LIGHT BULB

**CAUTION:** Before changing light bulb make sure you have disconnected power line plug from socket outlet.

**CAUTION:** This machine is designed to use a 15 watt maximum bayonet base bulb **only**.

### Removing Bulb

- With thumb of right hand push in and down on tab of light lens and lower the light bracket.
- Do not attempt to unscrew the bulb.
- Press it up into the socket and at the same time turn bulb over in direction shown to unlock the bulb pin and guide out of socket.

### Replacing Bulb

- Press new bulb into socket, with bulb pins entering slots of socket.
- Turn it over in direction shown to lock bulb in position.
- Push entire assembly up until it snaps in position.

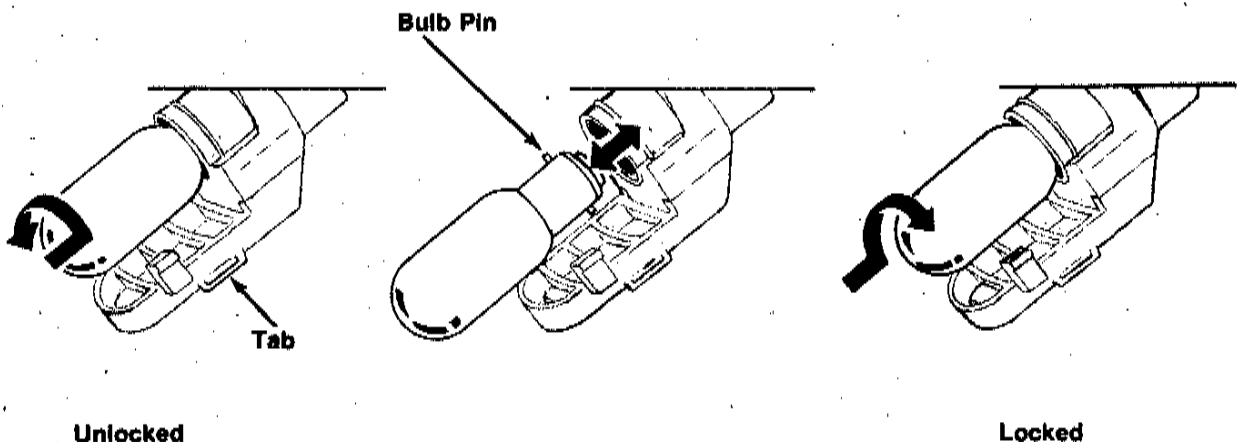

## Index

Accessories . . . . .	3	Needle Plate . . . . .	3, 5
Adjusting Stitches for Stretch Fabrics . . . . .	27	Changing Plate . . . . .	5
Appliqué . . . . .	22	Snap-in Feed Cover . . . . .	3, 5, 18, 34
Attaching a Button . . . . .	34	General Purpose . . . . .	3
Attaching Elastic . . . . .	31	Operating the Machine . . . . .	10
Bar Tacks . . . . .	20	Pattern Group Selector . . . . .	19, 25
Blindstitch Hem Guide . . . . .	3, 5, 29	Performance Checklist . . . . .	37
Blindstitch Hems . . . . .	29	Power and Light Switch . . . . .	10
Bobbin . . . . .	3, 11, 12, 14	Presser Feet . . . . .	3, 4
Raising Bobbin Thread . . . . .	14	Buttonhole Foot . . . . .	3, 32
Threading the Bobbin Case . . . . .	12	Changing Presser Feet . . . . .	4
Winding . . . . .	11	General Purpose Foot . . . . .	3
Bobbin Case . . . . .	12, 38	Special Purpose Foot . . . . .	3
Buttonholes . . . . .	32, 33	Zipper Foot . . . . .	3, 18
Changing Stitch Density . . . . .	33	Pressure Adjustments . . . . .	15, 20, 27
Buttons . . . . .	34	Principal Parts . . . . .	2
Caring for Your Machine . . . . .	38, 39	Reverse Stitching . . . . .	16
Choosing and Changing Accessories . . . . .	4, 5	Satin Stitching . . . . .	21
Connecting Machine . . . . .	10	Seams . . . . .	17, 23
Darning . . . . .	18	Lingerie . . . . .	23
Fabric, Thread and Needle Table . . . . .	8, 9	Straight . . . . .	17
Fabric Weight Table . . . . .	6, 7	Slide Plate . . . . .	39
Face Plate . . . . .	39	Speed Controller . . . . .	10
Free Arm Sewing . . . . .	36	Stitch Balance . . . . .	26, 33
Guiding and Supporting Fabric . . . . .	27	Stitch Length . . . . .	16, 20, 21, 26
Light Bulb . . . . .	39	Stitch Pattern Chart . . . . .	28
Machine Stitch Patterns . . . . .	24	Stitch Width Selector . . . . .	15, 19, 25
Mending a Tear . . . . .	30	Straight Stitching . . . . .	15
Needle . . . . .	4, 10	Threading the Machine . . . . .	13
Changing . . . . .	4	Twin-Needle . . . . .	35
Threading . . . . .	13	Zig-Zag Seam Finishes . . . . .	23
Thread Tension . . . . .	16, 20, 21	Zig-Zag Stitching . . . . .	19
Needle-Fabric Combinations . . . . .	10	Zipper Insertion . . . . .	18
Needle Position Selector . . . . .	15, 19, 25		

*To ensure that you are always provided with the most modern sewing capabilities, THE SINGER COMPANY reserves the right to change the appearance, design or accessories of this sewing machine when considered necessary.*



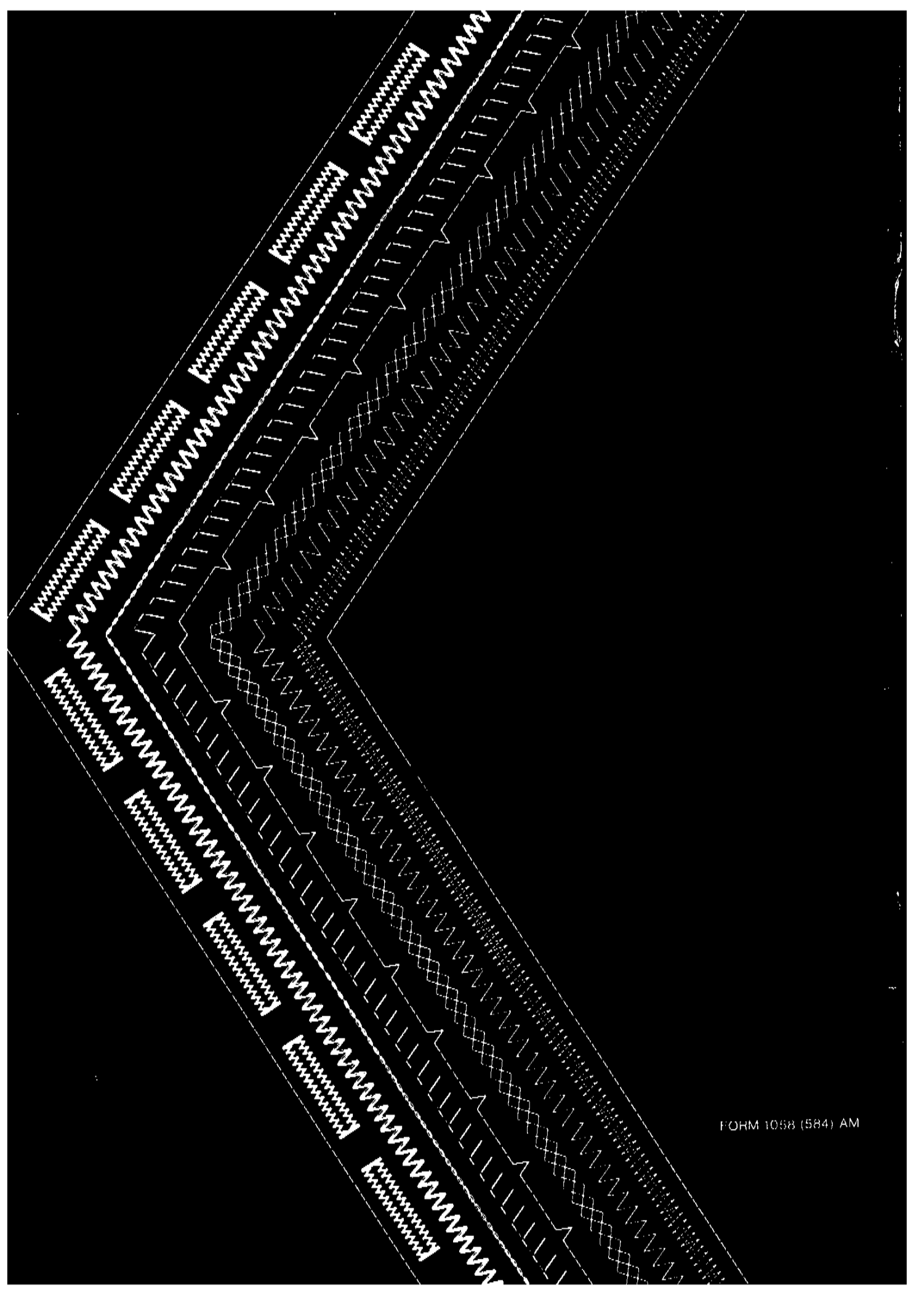

FORM 1058 (584) AM