

Wiring Diagram for Single Track Call Button – Older RED Trackmate Interface Board (Integration with Slot Car Corner Track Wiring Kit)

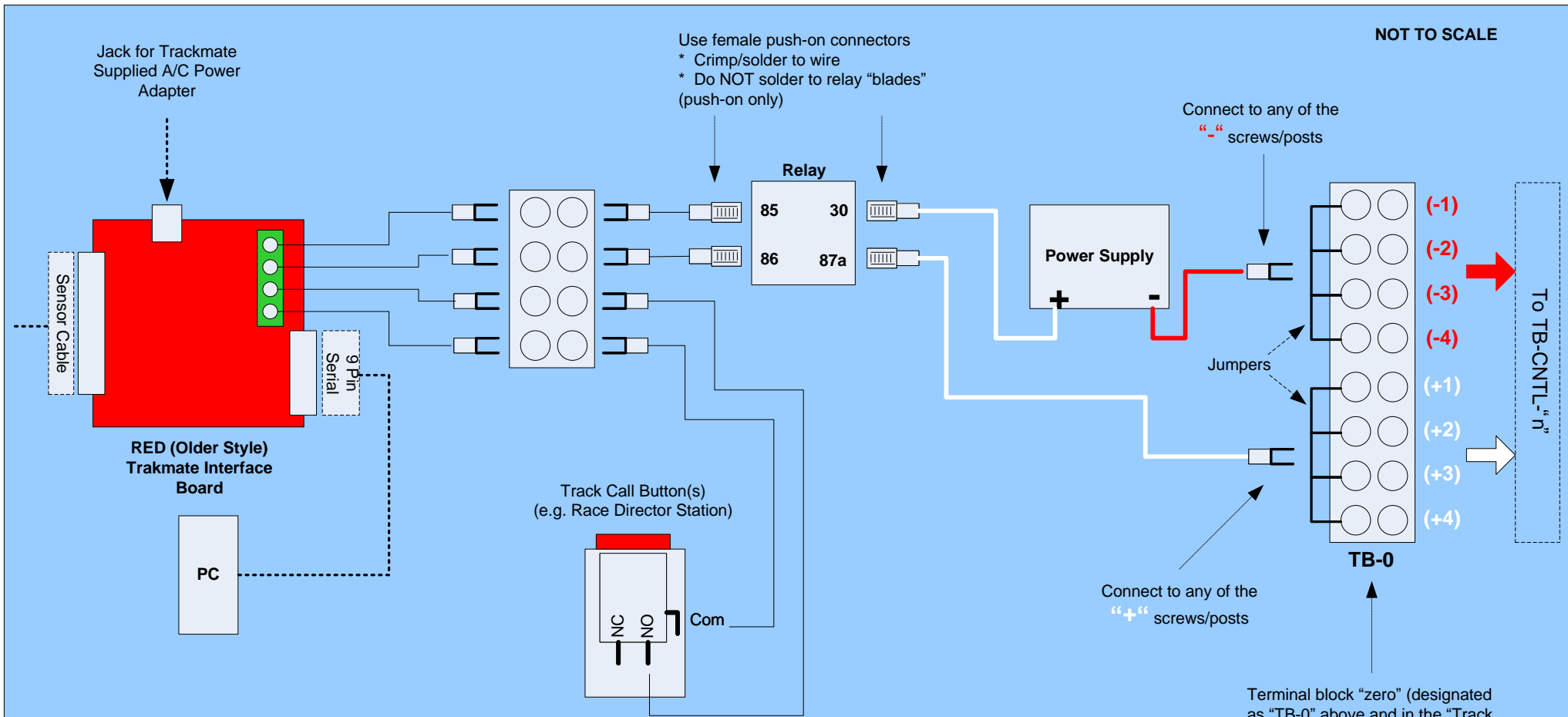

Disclaimer

While reasonable attempts to ensure the information in this diagram is accurate, Slot Car Corner does not warranty the accuracy of this diagram – use at your own risk. Slot Car Corner will not be responsible or liable for any damages you might cause or incur using this diagram. If you have questions, please contact us and we'll do our best to assist you.

This wiring diagram is intended to show an example of how to incorporate the **older (RED) Trackmate Interface board** into track wiring using a Slot Car Corner Track Wiring Kit. For information on the Trackmate track sensor cable(s) and PC interface cable connections, please refer to the Trackmate User Manual.

Notes:

1. Use 20 gauge stranded copper wire for all wiring shown with “thin” lines
2. Use 12 gauge stranded copper wire for all wiring shown with “thick” lines

*** Note ***

The same wiring approach can be easily adapted to layouts with any number of lanes provided a single power supply is being used.

SlotCarCorner.com