

1 Retirer l'embase Remove the base

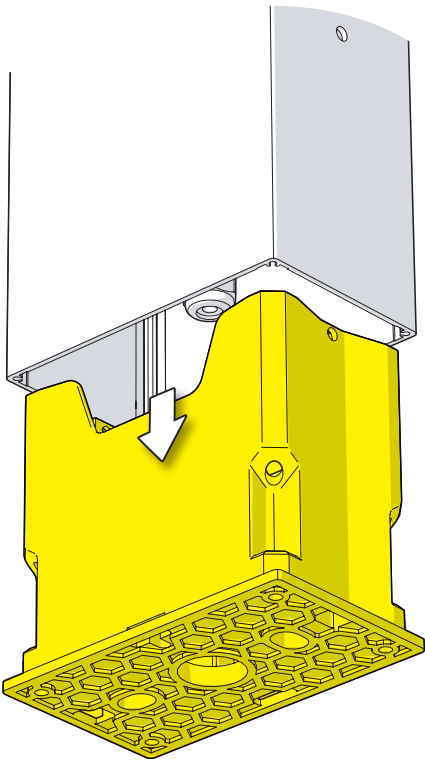

2 Fixation de l'embase au sol Fix the base to the ground

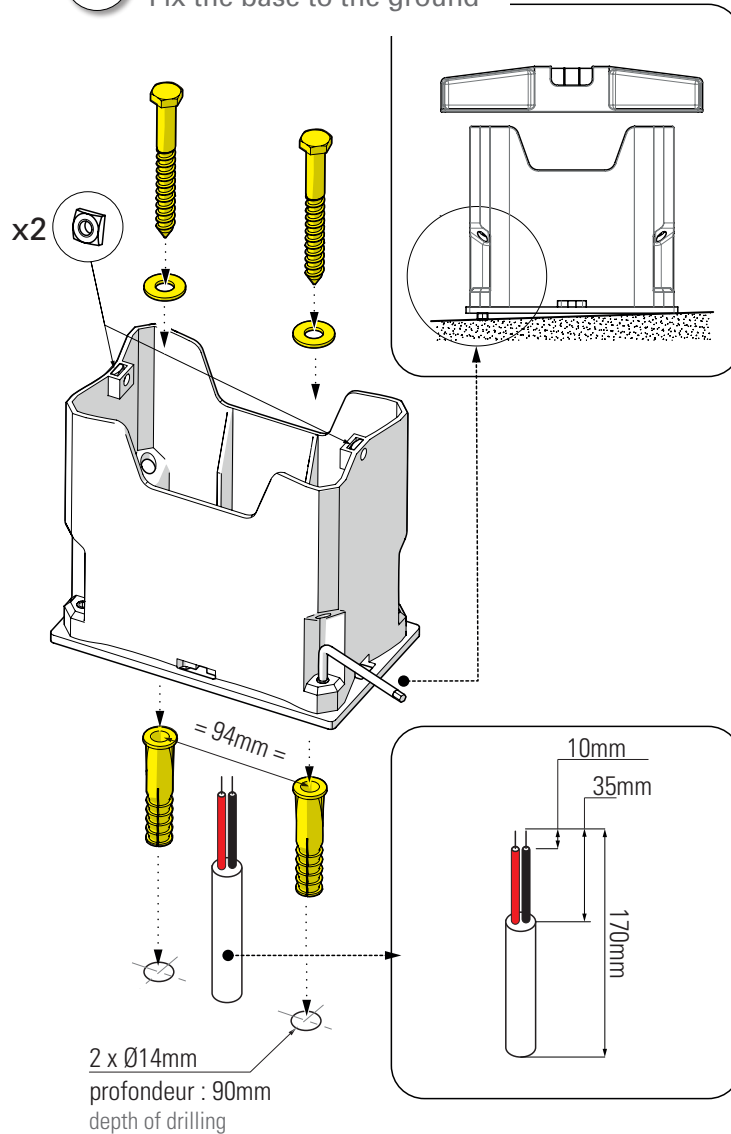

3 Raccordement électrique Connect electrical wires

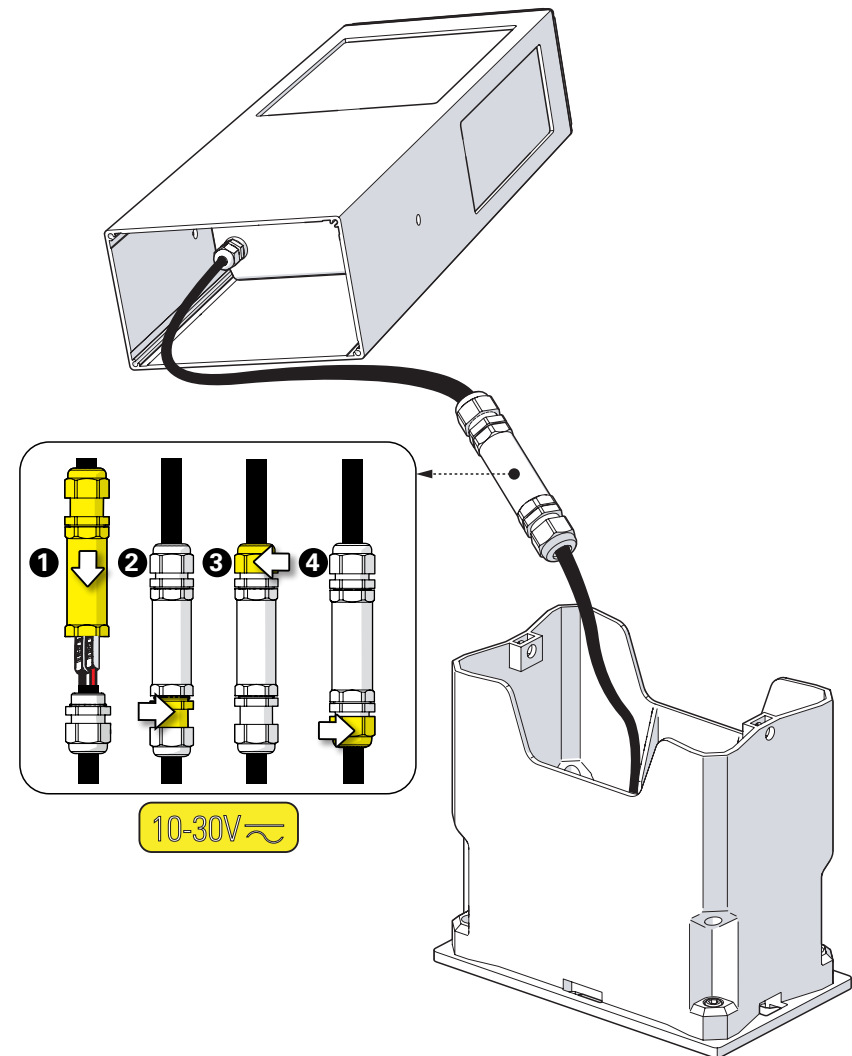

4 Fixation de la borne
Fix the bollard

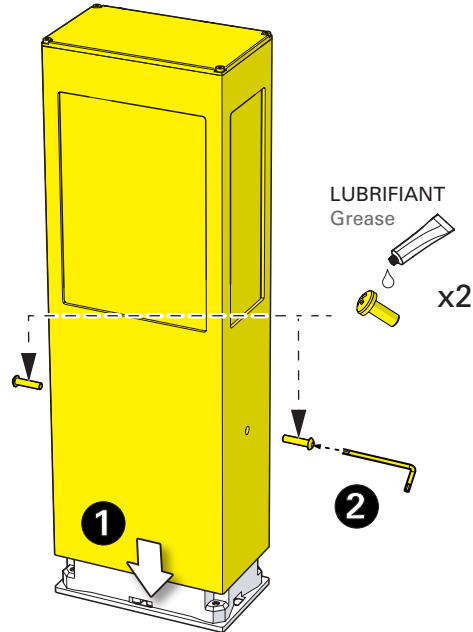

5 Retirer le couvercle supérieur
Remove the top cover

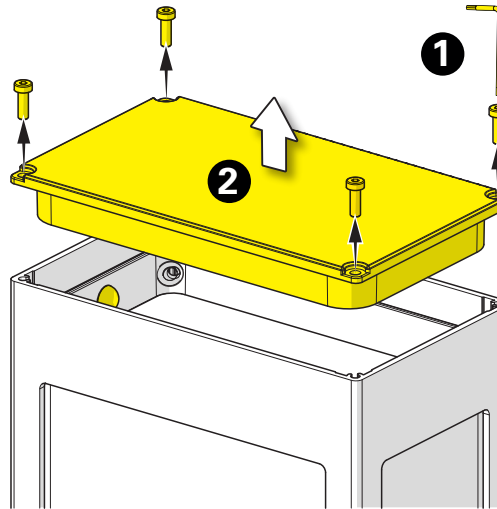

6 Extraire la plaque
Extract the plate

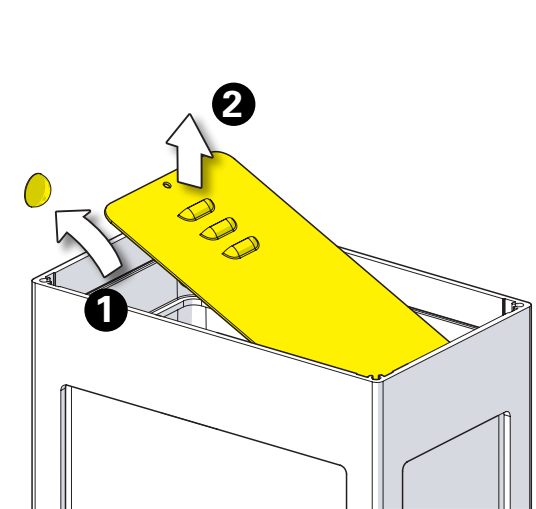

7 Montage de la lampe & du paralume
Install the light & the bulb cover

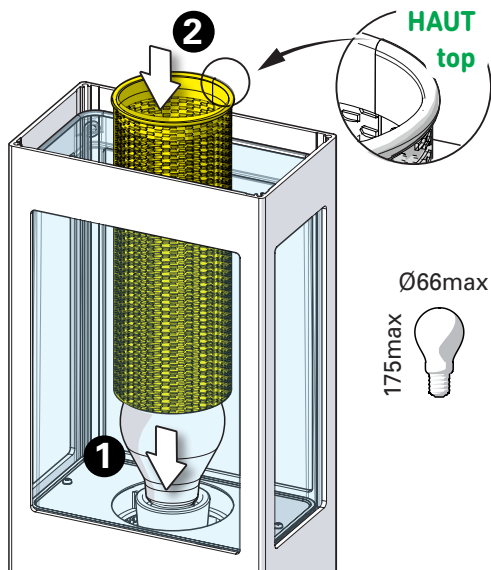

8 Remettre la plaque
Re-install the plate

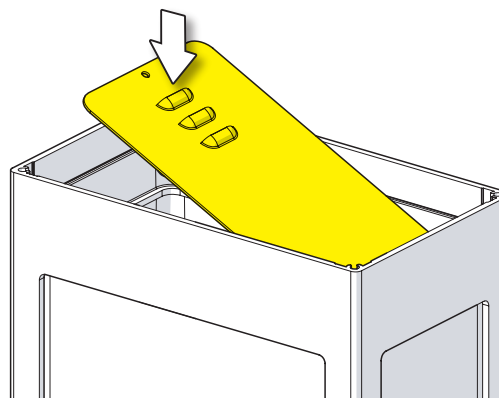

9 Remettre en place le couvercle
Put the top cover back in position

