

# SpaceLogic M3000

## Installation Instructions

Notice: Hot media hazard. Before removing actuator from valve or opening the valve, ensure that the valve control medium is isolated and relieve the pressure. Work should only be carried out by a competent engineer. To activate the manual override function, push and rotate the knob. Pull out again the knob to return to "AUTO" position.

- CE Compliance to European Union
- \* 2014/30/EU - ElectroMagnetic Compatibility [EMC] directive
- \* 2014/35/EU - Low Voltage Directive [LVD]
- \* 2011/65/EU - Restriction of Hazardous Substances [RoHS2] directive
- \* 2015/863/EU - Directive Amending RoHS2 (adding 4 Phthalates)

### Dimensions (mm)

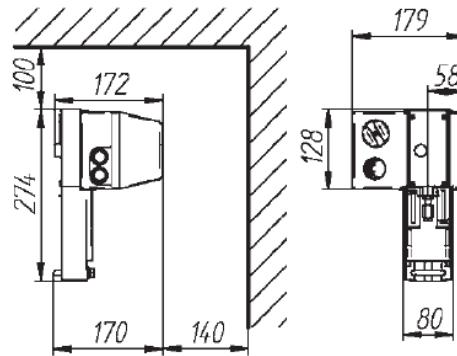

### Mounting

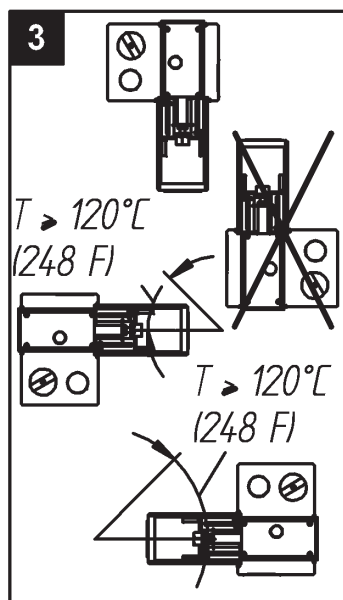
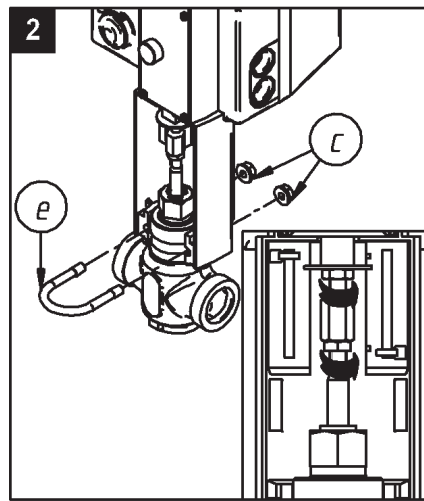
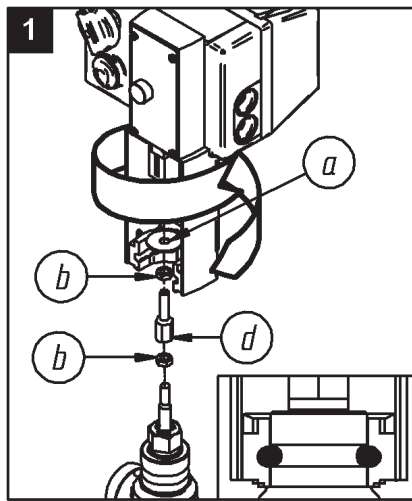
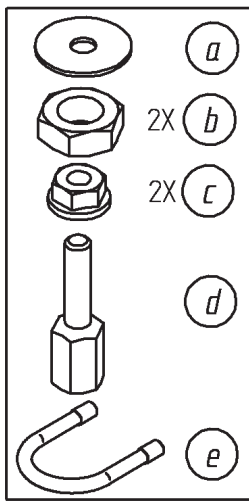

G, G0 = Max 100 m (328 ft.) ..... 1.5 mm<sup>2</sup> (AWG 15)  
 X1, MX, Y, VH, VC = Max 200 m (656 ft.)...0.5 mm<sup>2</sup> (AWG 20)

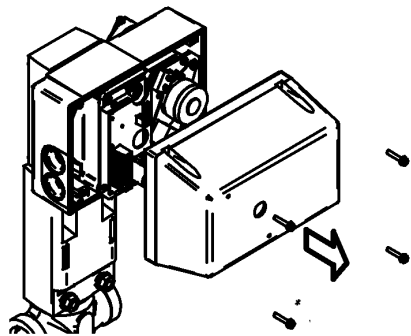
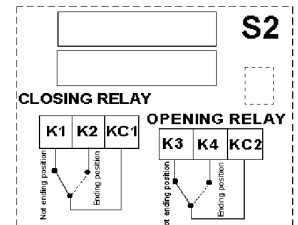
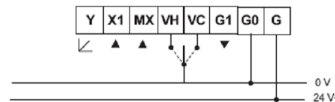

BLOCK	FUNCTION	DESCRIPTION
G	24Vac	Supply voltage
G0	24Vac return	Supply voltage
X1	Input VdC	Proportional control signal
M X*	Input Neutral	Proportional control signal
VH	Increase	Floating control
VC	Decrease	(VH, VC Short circuit on G0)
G1 (G0)	16Vcc Common	24mA max auxiliary Supply
Y (G0)	2-10 Vdc signal Common	State indication 0-100% feedback signal

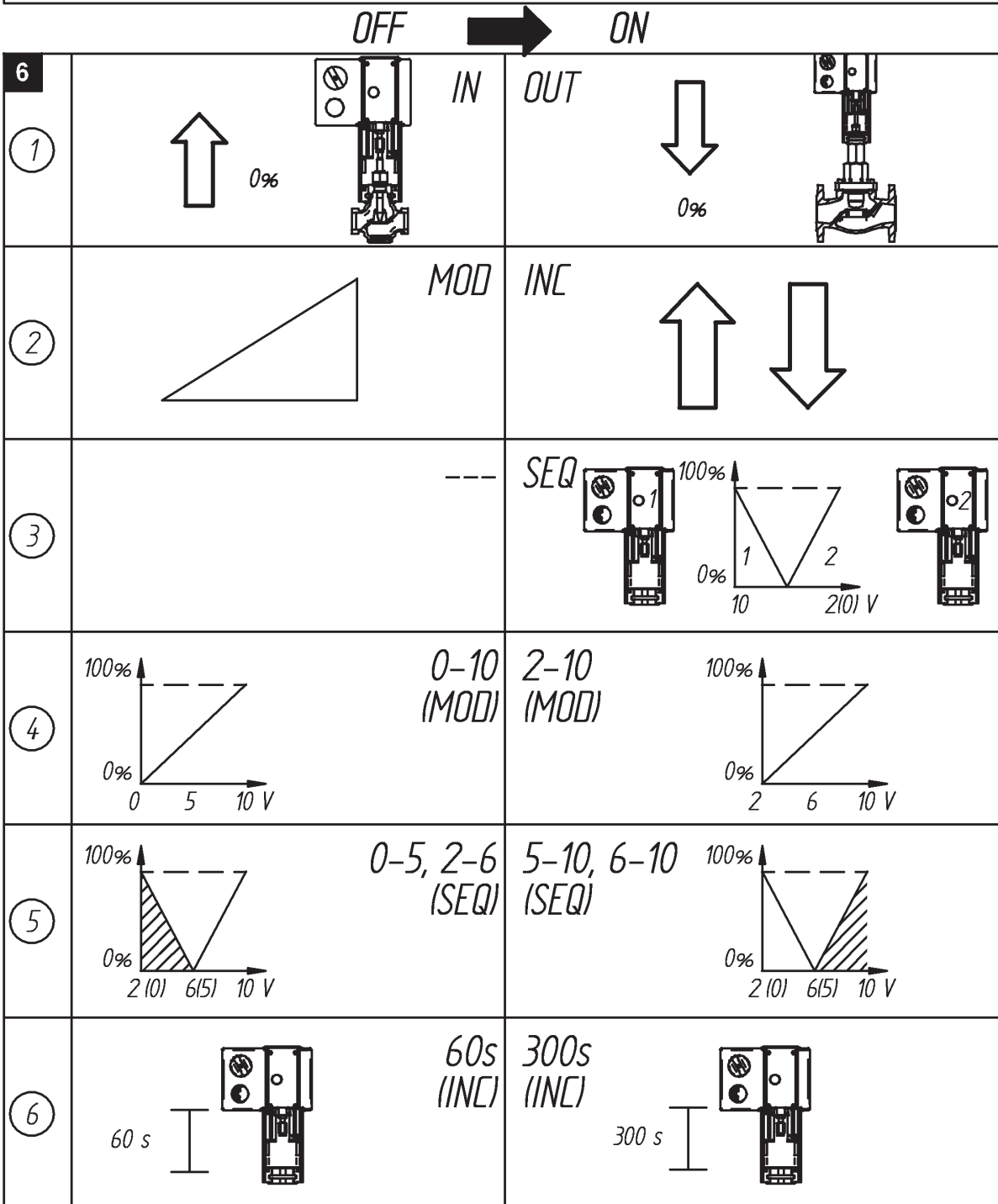
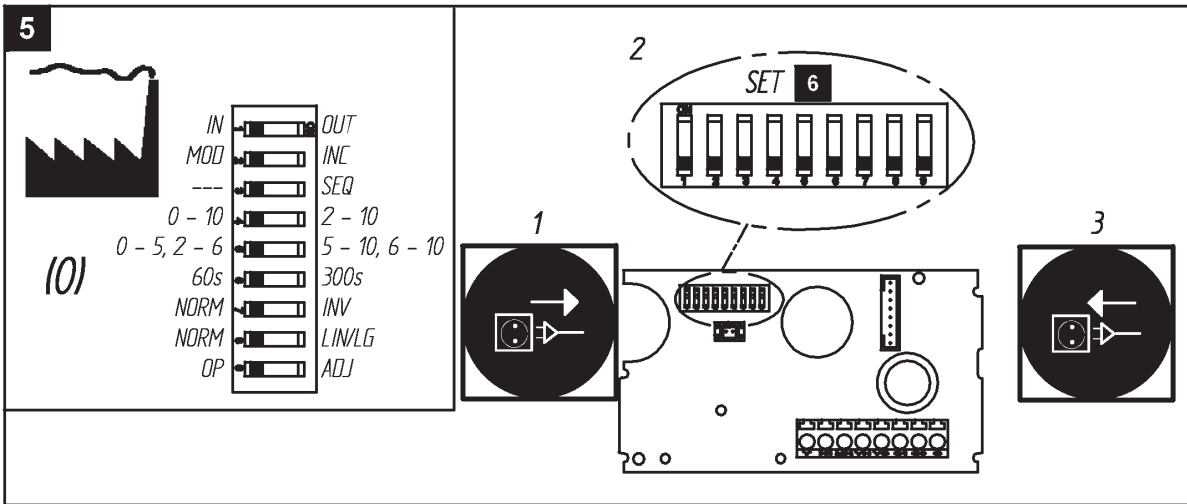

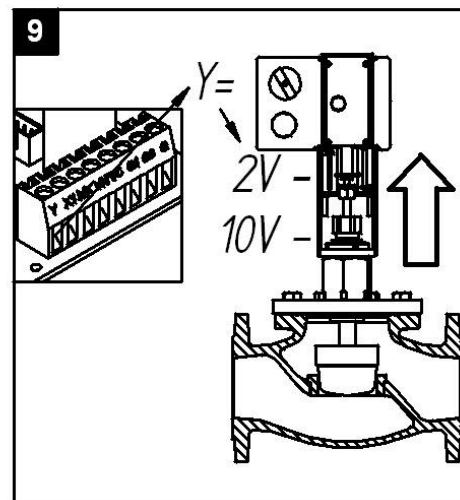
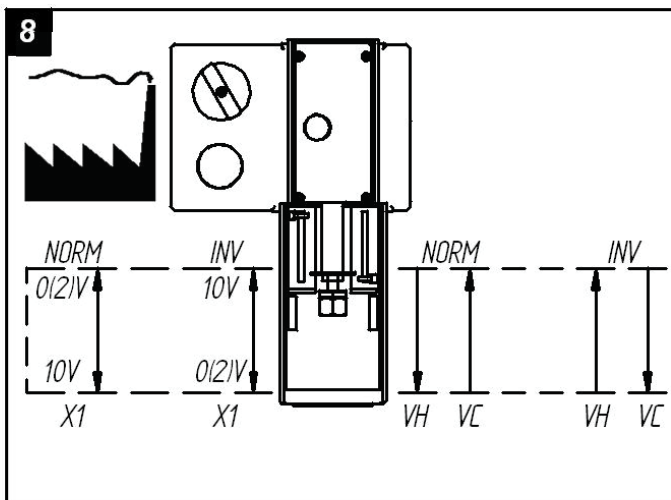
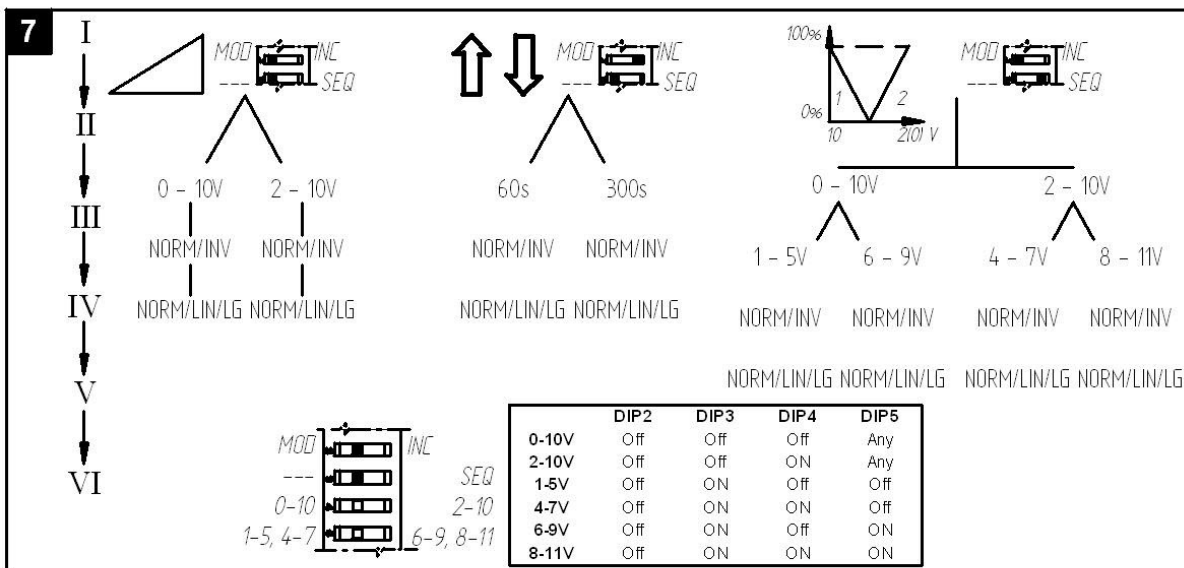
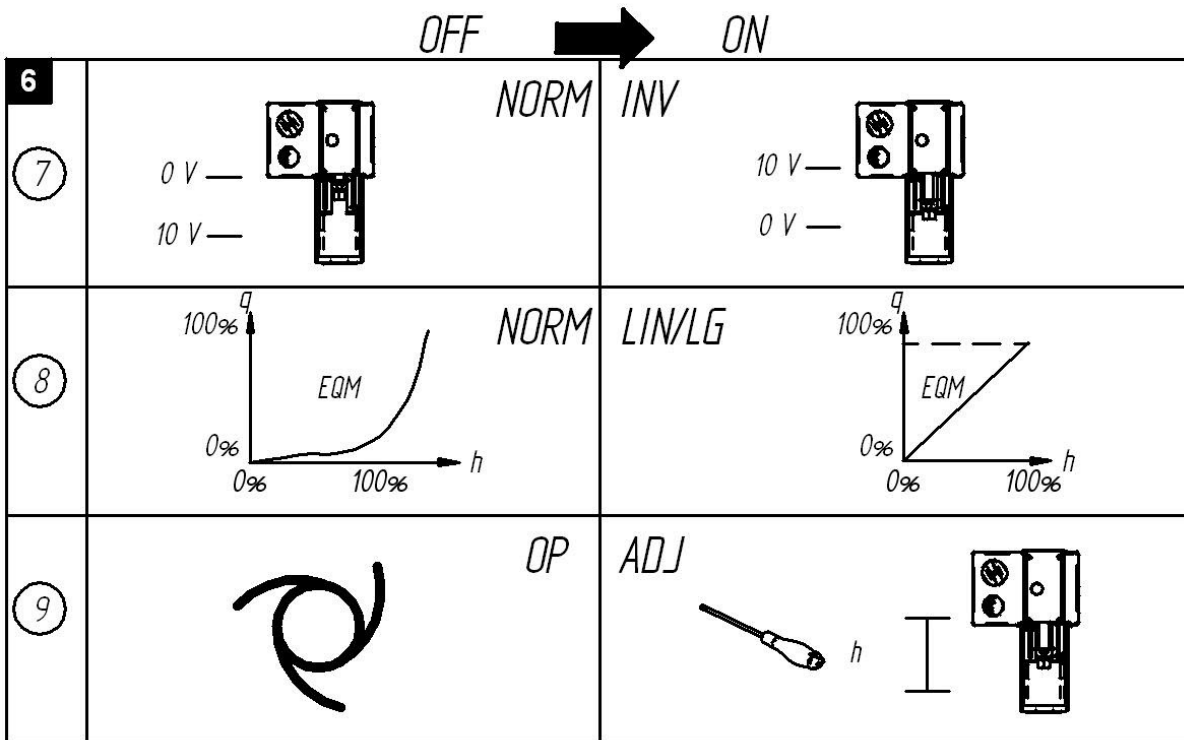

			Function in the "OFF" pos.	"ON" position	Description
IN	OUT	1	In	Out	Valve closing screw direction
MOD	INC	2	Modulating	Increase/decrease	Control (not at Sequence)
---	SEQ	3	-	Sequence	Sequence control
0-10	2-10	4	0-10 V	2-10 V	Voltage range
0-5 , 2-6	5-10 , 6-10	5	0-5 V, 2-6 V	5-10 V, 6-10 V	Part of voltage range
60 s	300 s	6	60 s	300 s	Running time
NORM	INV	7	Normal	Inverted	irection of movement
NORM	LIN/LG	8	Normal	Linear/Logarithmic	Valve characteristic
OP	ADJ	9	Operation	End position adjust (mom.)	Operation/End position adjustment

The 9 block dip switch is factory supplied with all switches in the 'Off' position

**1 Valve Closing Screw Direction— IN / OUT**

IN direction of movement is used when the screw of the actuator moves inwards (upwards) to close the valve.

OUT direction of movement is used when the screw of the actuator moves outwards (downwards) to close the valve.

**2 Control signal—MOD / INC**

**SpaceLogic** M3000 actuators can either be controlled by a variable direct voltage for a modulating signal (MOD), or by an increase/decrease signal (INC).

**3 Sequence or parallel control— -- / SEQ**

With sequence (or parallel) control (SEQ), two actuators/valves can be controlled by only one control signal. For each of these you can choose which part of the voltage range to use, the upper one, 5-10 V (6-10 V) or the lower one, 0-5 V (2-6 V). If the switch NORM / INV is in the NORM position, the higher voltage corresponds to 100% flow and the lower one to 0%. With NORM / INV in the INV position you will get the opposite function.

Note! If sequence or parallel control is not used, the switch --- / SEQ must be in the OFF position, as the switch MOD / INC is not valid during sequence or parallel control.

**4 Voltage range—0-10 / 2-10**

Choice of either 0-10V or 2-10V control voltage signal

**5 Part of voltage range— 0-5, 2-6 / 5-10. 6-10**

Choice to split voltage range low: 0 - 5 V (2 - 6 V), high: 5-10V (6 - 10 V)

If the switch is in the NORM position, the higher voltage corresponds to 100% flow and the lower one to 0%. To achieve the opposite function, the switch should be put in its INV position.

**6 Running time—60 s / 300 s**

With increase/decrease control, you can choose a running time between 60 s or 300 s.

With modulating control, the running time is always 15 s / 20 s / 30 s. depending on valve stroke

**7 Direction of movement— NORM / INV**

When normal direction of movement is used, the screw of the actuator moves inwards (up) when the control voltage decreases or if the actuator gets a decrease signal. With the switch NORM / INV, the direction of movement can be changed.

**8 Linearization—NORM / LIN/LG**

The motorized valve characteristics can be modified. If you wish for the characteristics to be affected, the setting LIN/LG will make the characteristics of an equally modified percentage (EQM) valve almost linear.

On the other hand, with LIN/LG a motorized valve equipped with a linear valve will operate with "Quick open characteristics". This means that with a small control signal, the valve will be almost completely open.

Note! For the actuator to register new settings for the switches, the supply voltage must be cut, the settings made, and then the power reconnected

or

the end position adjustment (see point 9) is initiated. (Does not apply to the switch OP/ADJ).

**9 End position adjustment— OP / ADJ**

This switch is only used to adjust the end positions when the actuator is commissioned. Momentarily put the switch in the ON position. The actuator will automatically find the end positions of the valve. At the end of the adjustment all the other dip switch settings (1 to 8) will be read again.

500 Ohm resistor for 4 to 20 mA control signals



500 Ohm resistor is supplied with the actuator in a plastic bag under the cover.

