

1 Scellement des tiges & fixation de la base

Install anchor J-Bolts in concrete foundation & fix the base

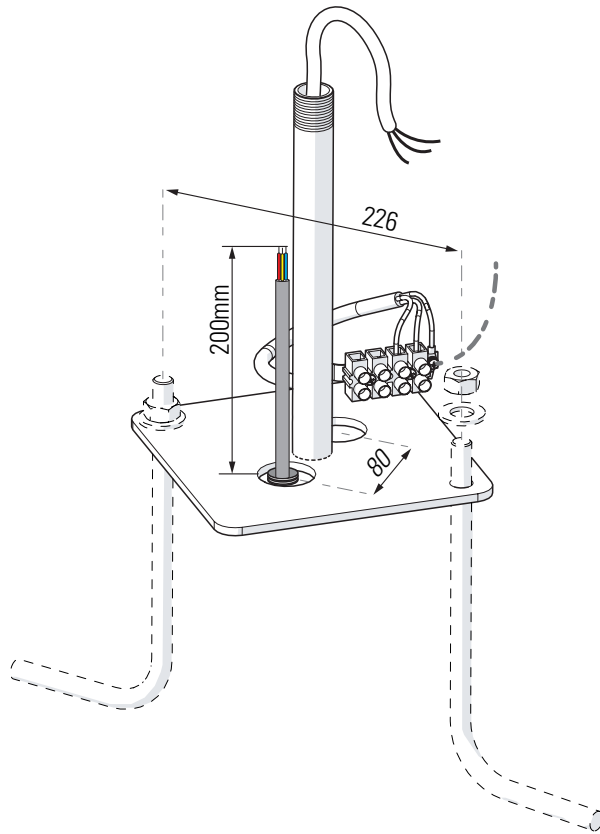

2 Raccordement électrique

Connect electrical wires

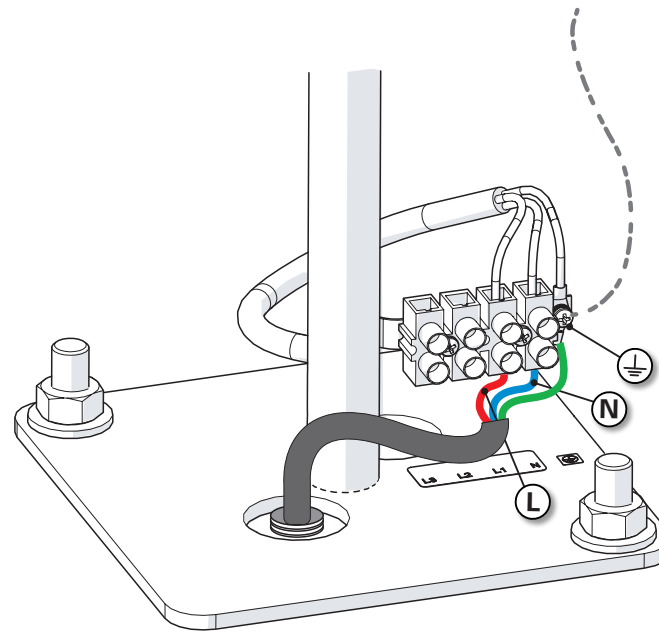

3 Engager le câble dans la fonderie

Engage the cable into the foundry

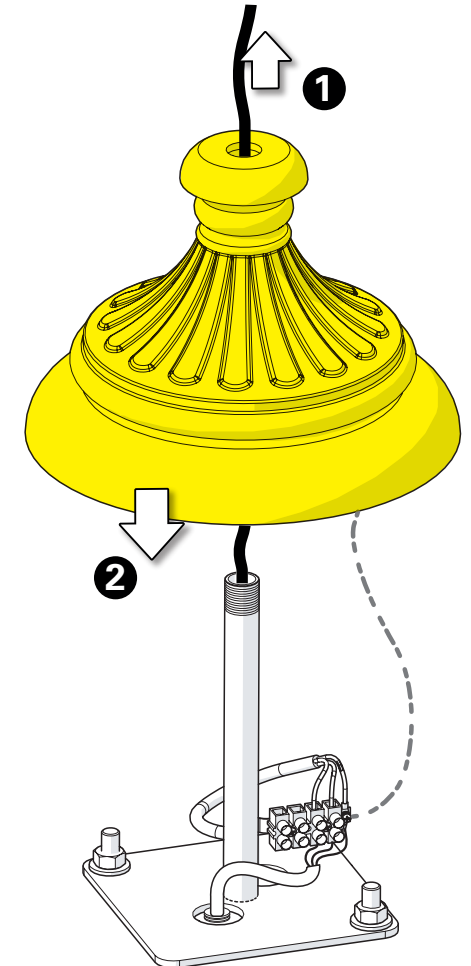

4 Préparation de la lanterne
Prepare the luminaire

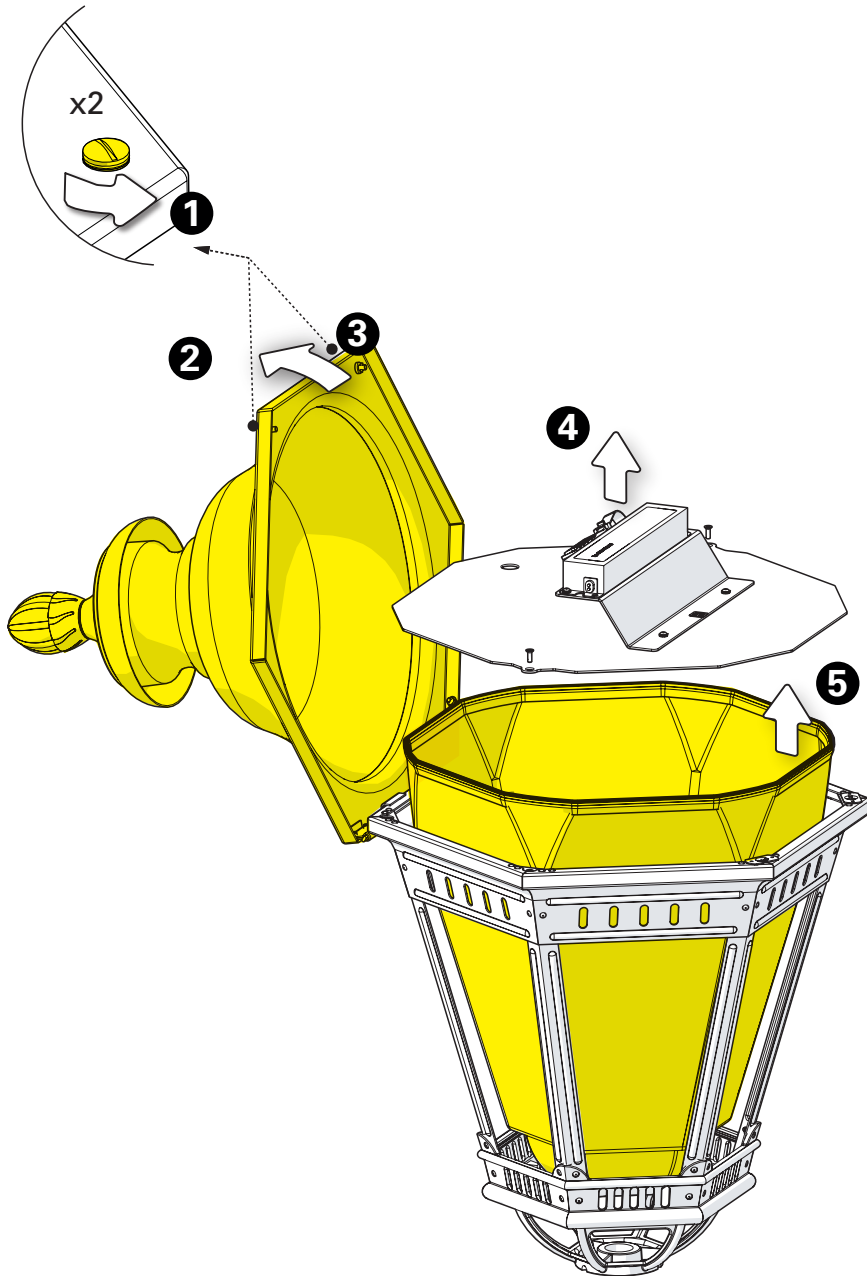

5 Montage de la tête sur la base
Mount the head on the base

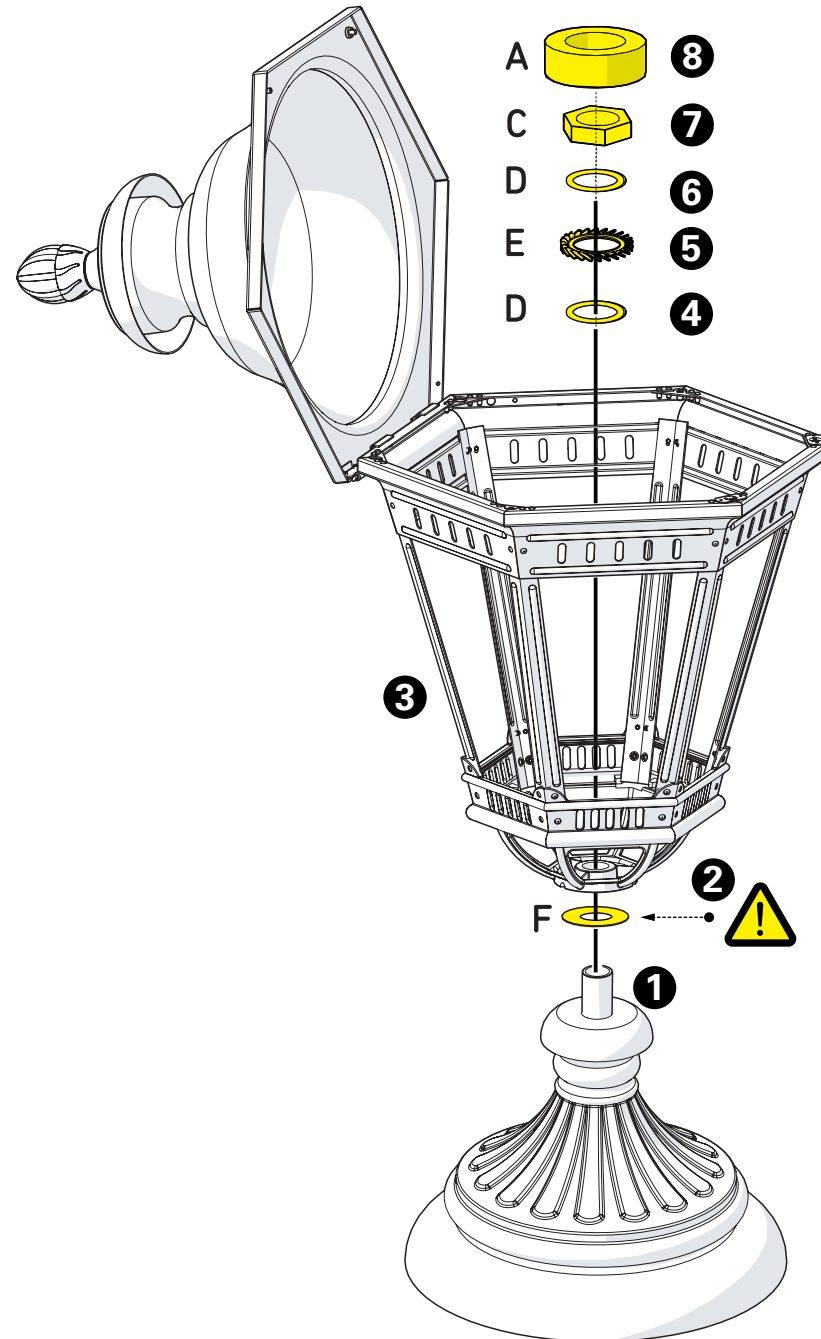

6 Montage de la verrine
& passage du câble
Put in place the glass
and insert cable into the conduit

7 Raccordement électrique
Connect electrical wires

8 Fermeture du chapiteau
Close the dome

