

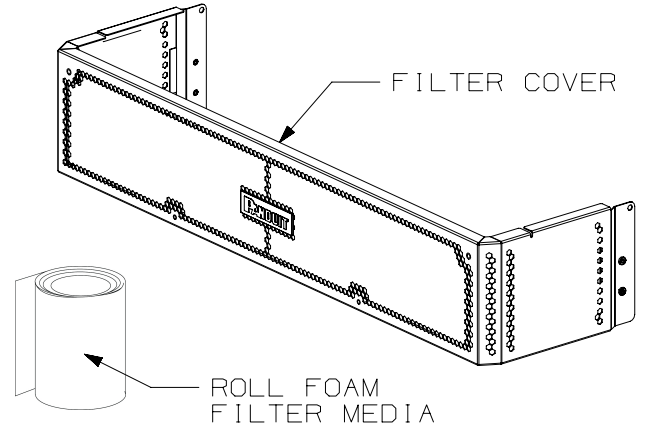

THIS COPY IS PROVIDED ON A RESTRICTED BASIS AND IS NOT TO BE USED IN ANY WAY DETRIMENTAL TO THE INTERESTS OF PANDUIT CORP.

NOTES:

1. VISIT OUR ON-LINE CATALOG AT WWW.PANDUIT.COM FOR A LIST OF CURRENT PARTS APPLICABLE FOR USE WITH THIS PRODUCT.
2. DIMENSIONS IN [] ARE METRIC.
3. ALL MATERIALS AND COMPONENTS USED MEET THE MATERIAL RESTRICTIONS OF RoHS (EUROPEAN DIRECTIVE 2011/65/EU ON THE RESTRICTION OF HAZARDOUS SUBSTANCES) AS PROPOSED BY THE RoHS TECHNICAL ADAPTATION COMMITTEE.
4. WEIGHT: 3 lb [1.4 kg]
5. PART INCLUDES:
 - (1) FILTER COVER
 - (1) ROLL FOAM FILTER MEDIA
 - (4) #10-32 SCREWS
 - (4) FLAT WASHERS
 - (2) M4 FLANGE HEAD LOCK NUTS

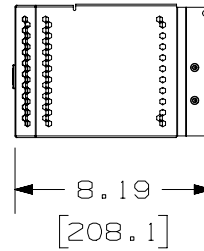
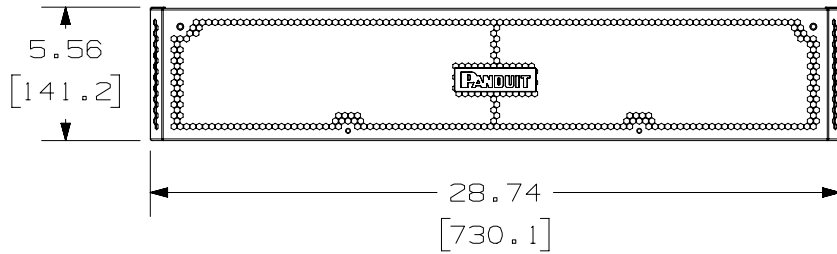
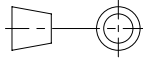

PART NUMBER		WME3BL-FKIT			
TITLE		3RU WALL MOUNT ENCLOSURE FILTER KIT			
		CUSTOMER DRAWING			
ITEM REVISION NAME		02164NAB/01			
DATASET FILE NAME		02164NAB_DC/01A			
 THIRD ANGLE PROJECTION					
MATERIAL					STEEL, POLYURETHANE FOAM
DRAWING NUMBER		02164NAB-DC			
REV	DATE	BY	CHK	SCALE	SIZE
00A	5-10-21	TWV	MDJR	NONE	A
DESCRIPTION		ECN		SHEET 1 OF 1	

A-SIZE CUSTOMER

2

1

2

1