



BOSCH

NEV 400 LSN Power supply

ISP-NEV400-120



en

Installation manual

Table of contents

1	Safety	4
2	Short information	7
3	System overview	8
4	Installation	10
4.1	Preparations	11
4.2	Removing the enclosure knockouts	12
4.3	Installing the tamper switch rail	13
4.4	Installing the enclosure	14
4.5	Installing the power supply and the AC terminal block	17
4.6	Installing the MAP accessory mounting plate	20
4.7	Installing a 12 V converter (optional)	22
4.8	Installing a SIV 28 fuse plate (optional)	24
4.9	Installing the EMIL expansion module	25
4.10	Installing a relay module (optional)	26
4.11	Installing the enclosure lockset	27
5	Cabling	28
5.1	Cabling overview	29
5.2	Connecting the thermistor	30
5.3	Connecting the tamper switch	30
5.4	Connecting the EMIL expansion module to the power supply	32
5.5	Connecting the auxiliary outputs	32
5.6	Connecting the LSN	33
6	Initial set-up and programming	34
6.1	Initial set-up	34
6.2	Programming	36
7	Troubleshooting	40
8	Maintenance	41
9	Technical data	42

1 Safety

**Danger!****Battery**

Injuries due to electric shock, fire or explosion are possible if the battery is handled or connected incorrectly.

- Always handle the battery carefully and replace it carefully.
- Make sure that the grounding terminal is always connected and that N, L or  are connected correctly.
- Make sure to first disconnect the positive wire of the battery when removing it from the system.
- Be careful when connecting the positive (red) wire and the "BATT +" port of the system. Make sure not to short-circuit with the "BATT +" port to prevent electric arc from occurring.

**Danger!****Electrostatic discharge**

Injuries and damage of electronic components are possible due to electrostatic discharge.

- Use antistatic wrist strap while working with the system.

**Danger!****Electricity**

Injuries due to electricity are possible if the system is not operated correctly or if the system is opened or modified not accordingly to this manual.

- To switch off the power, make sure to have a circuit breaker available.
- Ensure that the system is switched off during the installation, wiring and maintenance process.
- Only open or modify the system accordingly to this manual.
- Ensure to connect the system to the electric supply with a protective grounding contact.

-
- Only qualified installers/service personnel are allowed to install and maintain this system.
-



Danger!

Electricity

Injuries due to electricity are possible if the system is not grounded correctly.

- Ensure to ground the system correctly.
 - When installing the AC terminal block ensure to connect the ground wire to the ground connection point of the enclosure back wall.
-



Danger!

Electricity

Injuries and damage of the system due to wrong polarity and short circuits are possible.

When connecting wires and cables, ensure to use the correct polarity.



Caution!

Battery

Damage or contamination of the system is possible if the battery is not handled correctly or if the battery is not replaced on a regular basis.

- Only use a non-spillable battery.
 - Place a label with the last replacement date on the battery.
 - Under normal conditions of use, replace the battery every 3-5 years.
 - Recycle the battery after replacement according to local regulations.
-



Caution!

Installation

Damage or malfunction of the system is possible if the system is not mounted and installed correctly.

- Place the system inside the monitored area on a stable surface.
- Once the system is tested and ready to use, secure the enclosure door with screws.

**Caution!****Maintenance**

Damage or malfunction of the system is possible if it is not maintained on a regular basis.

- Ensure to get the system maintained once a year.
- Only qualified installers/service personnel are allowed to maintain this system.

**Old electrical and electronic appliances**

Electrical or electronic devices that are no longer serviceable must be collected separately and sent for environmentally compatible recycling (in accordance with the European Waste Electrical and Electronic Equipment Directive).

To dispose of old electrical or electronic devices, you should use the return and collection systems put in place in the country concerned.

2 Short information

The NEV 400 LSN provides a remote power supply and is installed offside a control panel. Trouble and tamper events are transmitted via LSN (local security network).

This manual contains information on how to install the NEV 400 LSN. It describes the main steps required for cabling and programming the system. Detailed information on the single components can be found in the correspondent datasheets and installation manuals.

3 System overview

The NEV 400 LSN contains the following components:

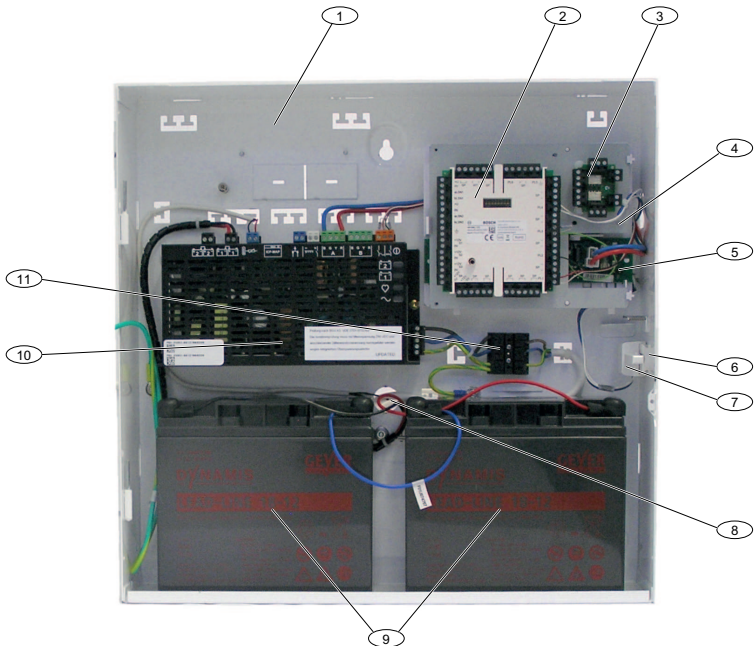

Figure 3.1: NEV 400 LSN system overview

Element	Description
1	ICP-MAP0120 expansion enclosure
2	ISP-PCBA-EMIL
3	IMS-RM relay module (optional)
4	ICP-MAP0021 accessory mounting plate EMIL
5	SIV 28 fuse plate (mounted on ICP-MAP0020 accessory mounting plate)
6	Tamper switch rail

Element	Description
7	ICP-MAP0055 expansion enclosure tamper switch
8	Thermistor
9	Batteries
10	IPP-MAP0005-2 MAP power supply 28V/150W
11	AC terminal block

4 Installation

This chapter contains information on how to install the components of the NEV 400 LSN.



Danger!

Electrostatic discharge

Injuries and damage of electronic components are possible due to electrostatic discharge.

- Use antistatic wrist strap while working with the system.
-



Caution!

Installation

Damage or malfunction of the system is possible if the system is not mounted and installed correctly.

- Place the system inside the monitored area on a stable surface.
- Once the system is tested and ready to use, secure the enclosure door with screws.

4.1 Preparations

- Use proper anchor and screw sets when installing the enclosure on surfaces. Refer to the drill template for detailed instructions.
- Ensure that there is enough free space to the left of the enclosure so that the enclosure door has full range of motion. 460 mm (18 in) for a fully opened door or 32 mm (1.25 in) for 90° opened door is required.
- Ensure that there is at least 100 mm (4 in) of space around the enclosure to allow easy access to cable conduits.
- To minimize battery depletion, install the enclosure in locations at normal room temperature.
- Use the ICP-MAP0120 Installation Mounting Template (F.01U.076.205).

4.2 Removing the enclosure knockouts

1. Unhinge and remove the enclosure door and set it aside.
2. Remove the enclosure knockouts in the order shown in the figure below.

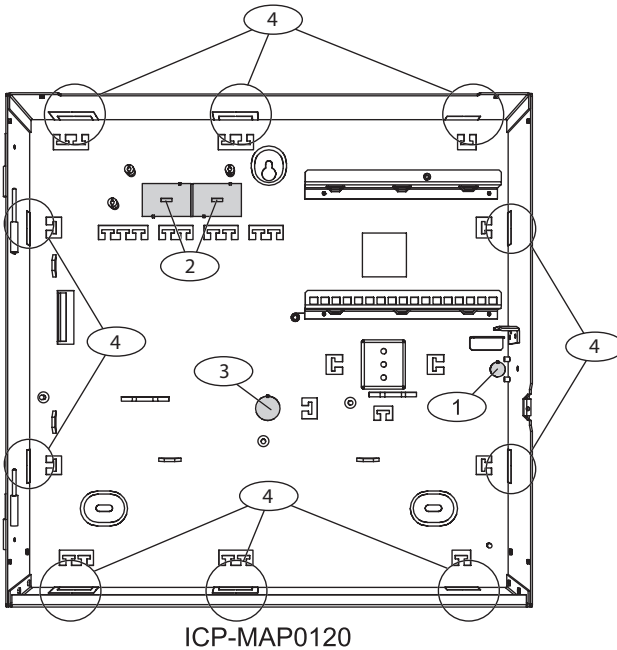

Figure 4.1: Removing the enclosure knockouts

Element	Description
1	Knockout for wall tamper (required in accordance with EN50131 grade 3)
2	Knockouts for wiring
3	Knockout for AC wires (used when AC wires come in from the back of the enclosure)
4	Side wall knockouts for wiring

4.3 Installing the tamper switch rail

1. Remove the tamper switch rail from the package.
2. Mount the tamper switch rail to the inner right side of the enclosure as shown in the figure below.
3. Secure the tamper switch rail with the two supplied screws.



Notice!

Do not mount the tamper switch at this time.

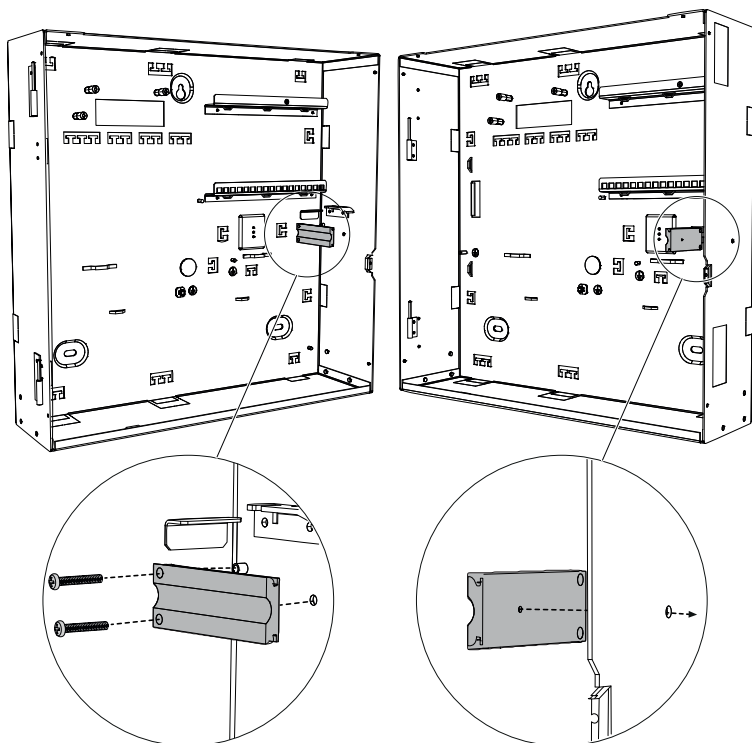

Figure 4.2: Installing the tamper switch rail

4.4 Installing the enclosure

Notice!



Ensure that there is enough free space to the left of the enclosure so that the enclosure door has full range of motion.

- For a fully opened door, at least 460 mm (18 in) is required.
 - For a door opened at 90°, at least 32 mm (1.25 in) is required.
-

Installing the wall tamper plug

1. Use the supplied drill template to mark the holes on the intended surface.
The drill template can be found in the enclosure box.
2. If a wall tamper is required, insert the plug for the tamper switch into the back of the enclosure (required in accordance with EN50131 grade 3) as shown in the figure below.
3. Secure the plug to the wall using a suitable screw (not supplied).

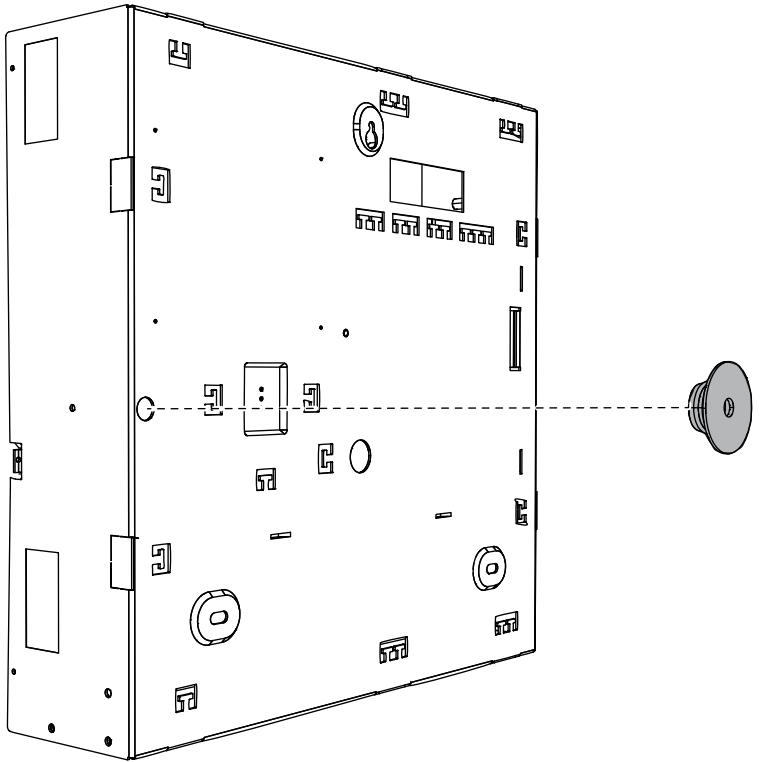

Figure 4.3: Installing the wall tamper plug

Mounting the enclosure

1. Mount the enclosure to the intended surface using suitable screws and anchors (not supplied). Use the mounting holes as shown in the figure below.
2. Ensure that all screws are tight and that the enclosure is securely fastened to the mounting surface.

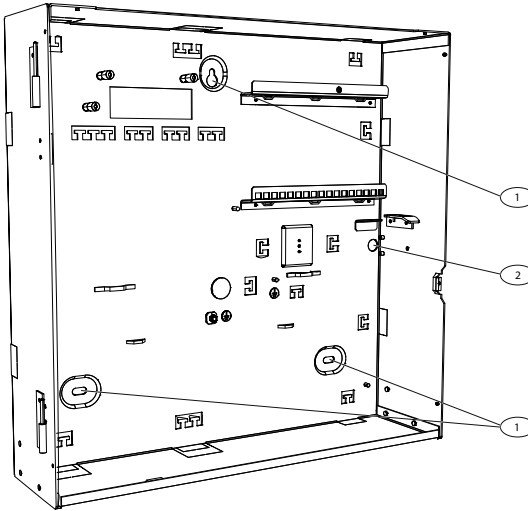

Figure 4.4: Mounting the enclosure

Element	Description
1	Mounting hole
2	Hole for screw to secure wall tamper plug

4.5 Installing the power supply and the AC terminal block



Caution!

Debris

Damage to the power supply due to debris during the installation is possible.

- To prevent damage to the power supply during installation, fit the supplied protective dust cover label on top of the power supply before installing it.

Installing the power supply

1. Slide the left side of the power supply against the flange on the left side of the enclosure back wall (1) and align the top of the power supply to the enclosure back wall (2) as shown in the figure below.
2. Align the cut-out on the right side of the power supply as shown in the figure below (3).
3. Secure the power supply to the enclosure back wall with the supplied hardware in the following order: tooth washer, washer, hex nut (4).

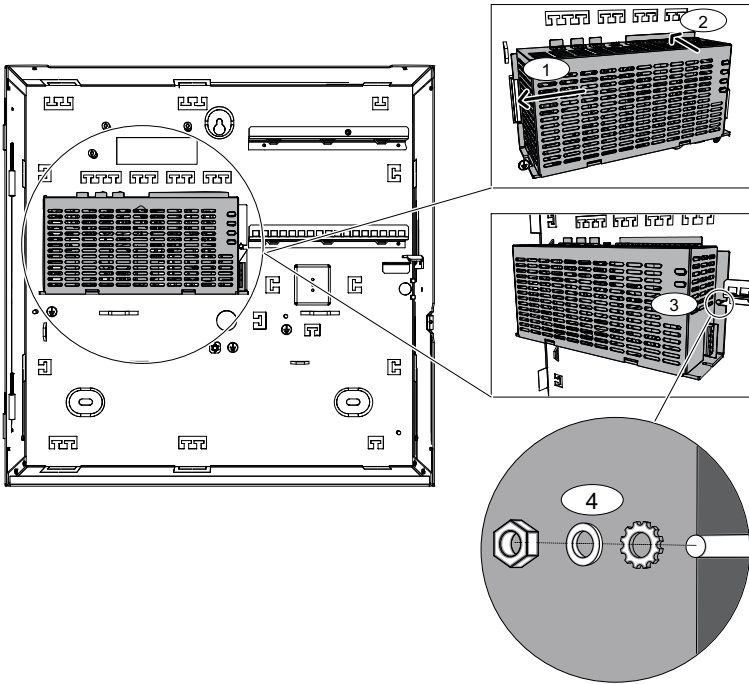

Figure 4.5: Installing the power supply

Installing the AC terminal block

Installing the AC terminal block

1. Mount the AC terminal block to the enclosure back wall into the corresponding mounting holes as shown in the figure below and secure it with the supplied screws (1).
2. Plug the terminal block connected to the AC terminal block into the power supply as shown in the figure below (2).
3. Connect the ground wire to the ground connection point of the enclosure back wall as shown in the figure below (3).

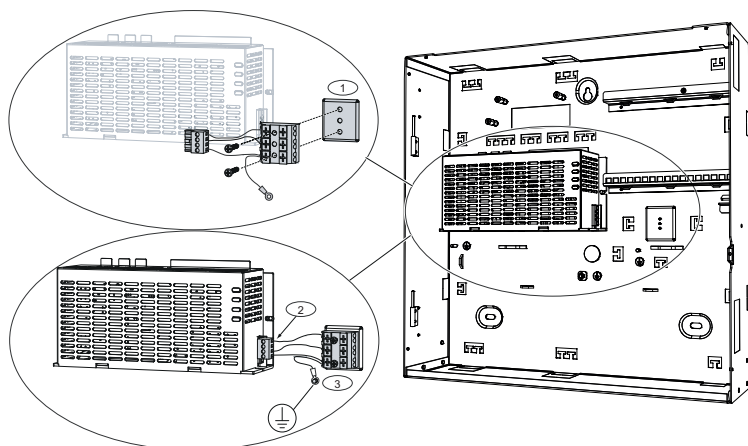

Figure 4.6: Installing the AC terminal block



Danger!

Electricity

Injuries due to electricity are possible if the system is not grounded correctly.

- Ensure to ground the system correctly.
- When installing the AC terminal block ensure to connect the ground wire to the ground connection point of the enclosure back wall.

4.6 Installing the MAP accessory mounting plate

1. Align the earth ground stud on the MAP accessory mounting plate with the earth ground hole on the top mounting rail in the upper right side of the enclosure wall as shown in the figure below.
2. Slide the clips on the back of the MAP accessory mounting plate onto the top and bottom mounting rails.

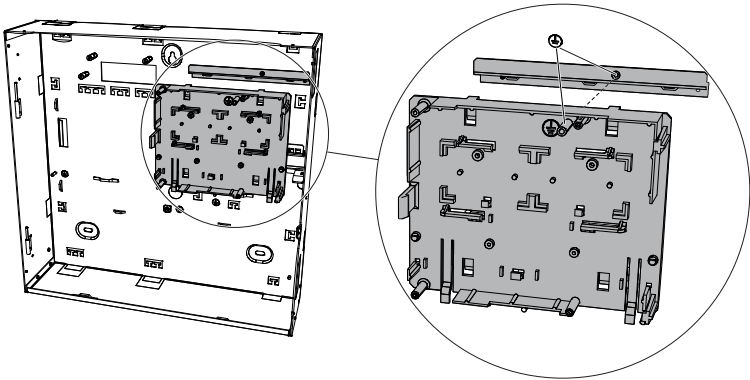

Figure 4.7: Installing the accessory mounting plate – frontview

3. Ensure that the locking clips snap into the bottom mounting rail as shown in the figure below.

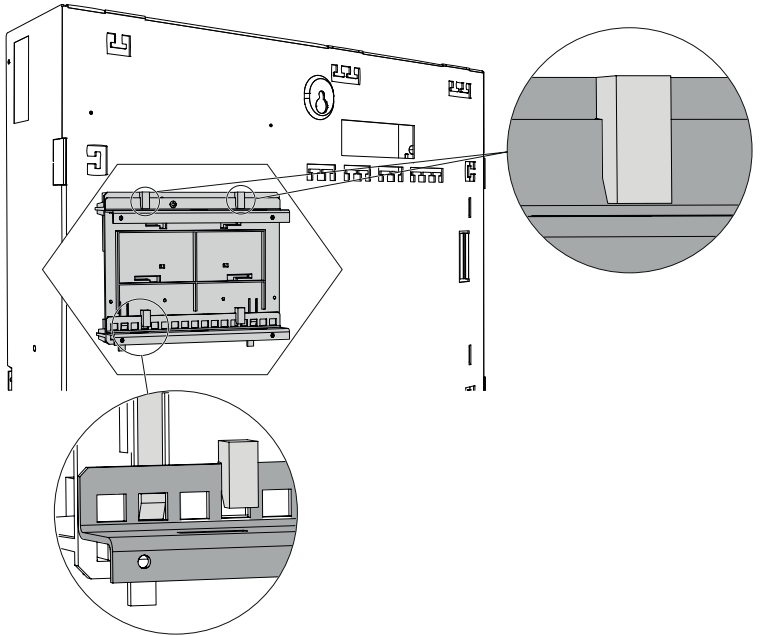

Figure 4.8: Installing the MAP accessory mounting plate - backview

4.7 Installing a 12 V converter (optional)

It is optional to install up to two 12 V converters onto the MAP accessory mounting plate.

1. Mount one or two 12 V converters onto the MAP accessory mounting plate as shown in the figure below.
2. Secure each 12 V converter with an M 3.5 x 5 mm screw (not supplied).

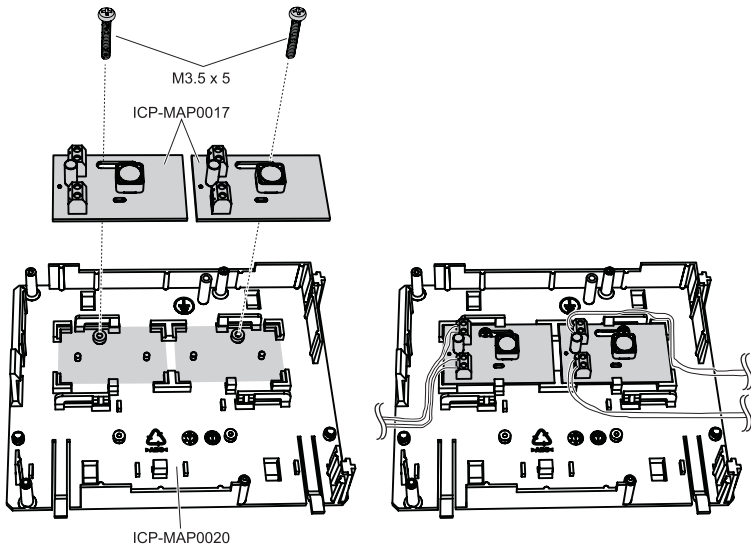

Figure 4.9: Installing the 12 V converter

Cabling a 12 V converter

Danger!

Electricity



Injuries and damage of the system due to wrong polarity and short circuits are possible.

When connecting wires and cables, ensure to use the correct polarity.

For an overview of the cabling, refer to *Cabling overview*, page 29.

1. Connect two wires to each of the terminal blocks of the 12 V converters as shown in the figure above.
2. Connect the two wires that lead to the input terminal block of the 12 V converter to terminal 1 and 2 of the EMIL expansion module.
3. Use the two other wires as auxiliary output 12 VDC.

4.8 Installing a SIV 28 fuse plate (optional)

It is optional to install a SIV 28 fuse plate onto the MAP accessory mounting plate.

1. Mount the SIV 28 onto the MAP accessory mounting plate as shown in the figure below.
2. Secure the SIV 28 with two M 3.5 x 5 mm screws (not supplied).

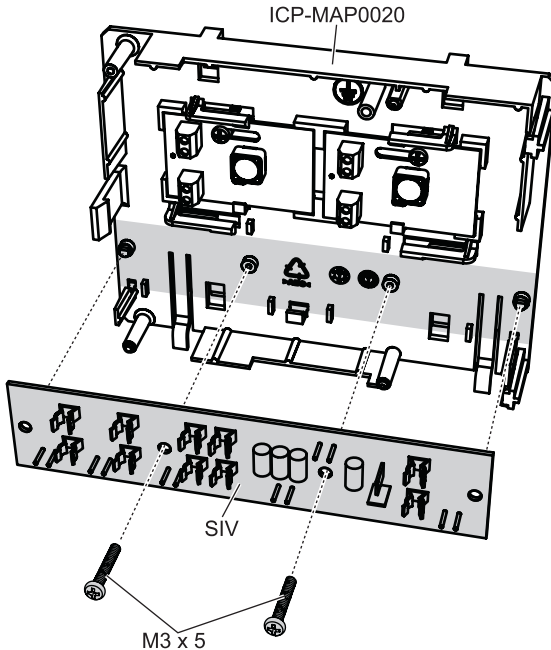

Figure 4.10: Installing a SIV 28

Cabling a SIV 28 fuse plate

Danger!

Electricity



Injuries and damage of the system due to wrong polarity and short circuits are possible.

When connecting wires and cables, ensure to use the correct polarity.

For an overview of the cabling, refer to *Cabling overview*, page 29.

1. Connect the prewired cable supplied with the SIV 28 to the terminal block of the SIV 28.
2. Clip off the connector from the other end of the cable and connect the two wires to B and R of the terminal block B of the power supply.
3. Connect a wire to the SIST output of the SIV 28.
4. Connect the other end of the wire to terminal 39 of the EMIL expansion module and insert a EOL resistor to terminal 39 and 40 of the EMIL expansion module.
5. Use the five SIV 28 outputs as auxiliary outputs 28 VDC.

Notice!



Use the corresponding ratings for the fuses SI 1 ... SI 5. (minimum 250 mA, maximum 1 A depending on the connected loads).

The overall current of all SIV 28 outputs must not exceed the available maximum current of the voltage output used.

4.9 Installing the EMIL expansion module

1. Remove the cover of the EMIL expansion module.
2. Mount the EMIL expansion module on the MAP accessory mounting plate EMIL using six distance bolts and two screwable distance bolts (supplied).

Notice!



If you want to install an optional relay module, refer to *Installing a relay module (optional)*, page 26 before performing the following step.

3. Mount the MAP accessory mounting plate EMIL on the accessory mounting plate and click it into place.

4. Fasten the MAP accessory mounting plate EMIL using three screws (supplied).

4.10 Installing a relay module (optional)

1. Insert the two corner distance bolts (supplied) into the designated left holes on the upper right side of the MAP accessory mounting plate EMIL and fasten the screws from underneath.
2. Insert the screwable distance bolt (supplied) into the designated middle hole on the upper right side of the MAP accessory mounting plate EMIL.
3. Insert the relay module into the corner distance bolts and fasten the screw of the distance bolt from above.
4. Mount the MAP accessory mounting plate EMIL on the MAP accessory mounting plate and click it into place.
5. Fasten the MAP accessory mounting plate EMIL using three screws (supplied).

4.11 Installing the enclosure lockset

1. Remove the lockset knockout from the enclosure door as shown in the figure below (1).
2. Insert the lockset into the opening on the enclosure door as shown in the figure below (2).
3. Secure the lockset with the nut as shown in the figure below (3).

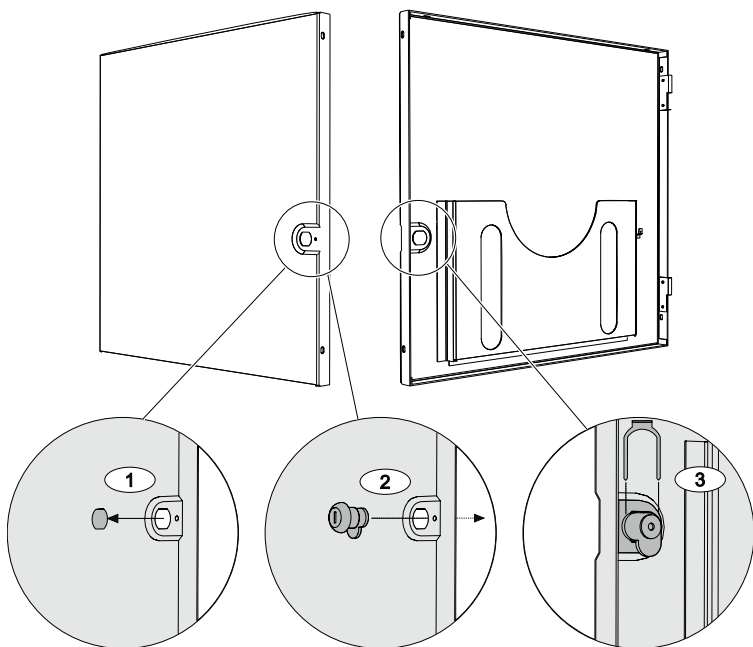

Figure 4.11: Installing the enclosure lockset

5 Cabling

This chapter contains information on how to wire the components of the NEV 400 LSN.

**Danger!**

Electrostatic discharge

Injuries and damage of electronic components are possible due to electrostatic discharge.

- Use antistatic wrist strap while working with the system.

**Danger!**

Electricity

Injuries and damage of the system due to wrong polarity and short circuits are possible.

When connecting wires and cables, ensure to use the correct polarity.

5.2 Connecting the thermistor

For an overview of the cabling, refer to *Cabling overview*, page 29.

1. Connect the thermistor cable (supplied, P/N F01U074759) to terminal block 3 of the power supply.
2. Mount the thermistor cable around the power supply as shown in the figure below.
3. Secure the thermistor with the supplied adhesive tape beneath the power supply in the center of the enclosure in between the space reserved for the two batteries.

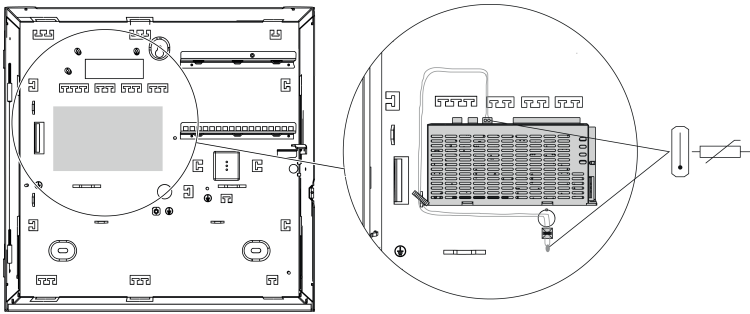

Figure 5.2: Connecting the thermistor

5.3 Connecting the tamper switch

1. Slide the extension piece of the tamper switch to position C as shown in the figure below.
If a wall tamper plug was installed (refer to *Installing the enclosure*, page 14), the position of the expansion piece of the tamper switch must be chosen in a way that lifting the enclosure off the wall by > 5 mm leads to reliable activation of the tamper switch.

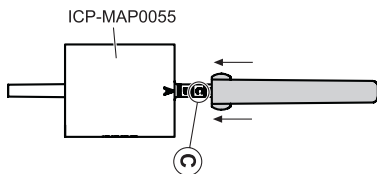

Figure 5.3: Tamper switch extension piece

2. Slide the tamper switch onto the rail as shown in the figure below.

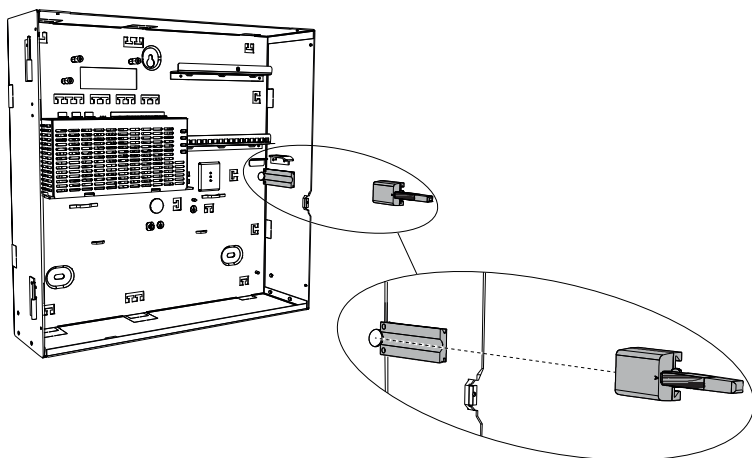

Figure 5.4: Installing the tamper switch

3. Clip off the connector from the cable of the tamper switch as shown in the figure below.
4. Connect the cable of the tamper switch to terminal 43 and 44 of the EMIL expansion module.

For an overview of the cabling, refer to *Cabling overview*, page 29.

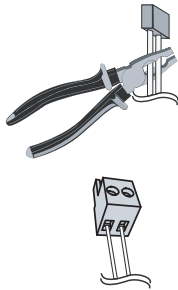

Figure 5.5: Tamper switch connection

5.4 Connecting the EMIL expansion module to the power supply

For an overview of the cabling, refer to *Cabling overview*, page 29.

1. Connect two wires to terminal 5 and 6 of the EMIL expansion module.
2. Connect the other end of the two wires to the white terminal block - + of the power supply.
3. Connect the terminal block with one wire of the prewired cable supplied with the EMIL expansion module to terminal 35 of the EMIL expansion module.
4. Connect the terminal block with two wires of the prewired cable to terminal 31 and 32 of the EMIL expansion module.
5. Connect the orange terminal block of the prewired cable to the rightmost position on top of the power supply.

5.5 Connecting the auxiliary outputs

For an overview of the cabling, refer to *Cabling overview*, page 29.

Connecting AUX 1 (28 VDC)

1. Connect two wires to B and R of the terminal block B of the power supply
2. Use the other end of the wires as AUX output 1.

Connecting AUX 2 (28 VDC)

1. Connect two wires to B and R of the terminal block A of the power supply
2. Use the other end of the wires as AUX output 2.

If supervised AUX 28 VDC outputs are needed, use a optional fuse plate (SIV 28). For more information, refer to *Installing a SIV 28 fuse plate (optional)*, page 24.

If a AUX 12 VDC output is needed, use a optional 12 V converter. For more information, refer to *Installing a 12 V converter (optional)*, page 22.

5.6 Connecting the LSN

For an overview of the cabling, refer to *Cabling overview*, page 29.

Connecting LSN 1

1. Connect two wires to terminal 3 and 4 of the EMIL expansion module.
2. Use the other end of the wires as LSN output 1.

Connecting LSN 2

1. Connect two wires to terminal 7 and 8 of the EMIL expansion module.
2. Use the other end of the wires as LSN output 2.

6 Initial set-up and programming

6.1 Initial set-up

Before initial set-up, check the following:

- Are all cables connected correctly?
- Is the power supply in correct operation after the AC mains has been connected and is the AC breaker switched on?

Danger!



Electricity

Injuries and damage of the system due to wrong polarity and short circuits are possible.

When connecting wires and cables, ensure to use the correct polarity.

For an overview of the cabling, refer to *Cabling overview*, page 29.

1. Remove the protective dust cover label from the top of the power supply.
2. Mount the two batteries into the bottom of the enclosure.
3. Switch the AC breaker on.
4. Ensure that there are no power-related trouble conditions.
5. Ensure that the AC LED indicator on the power supply turns on steady before connecting the battery terminals to the power supply.
6. Connect the battery cable leads to the batteries as shown in the figure below.
7. Connect the battery cable to the terminal block BATT 1 of the power supply.

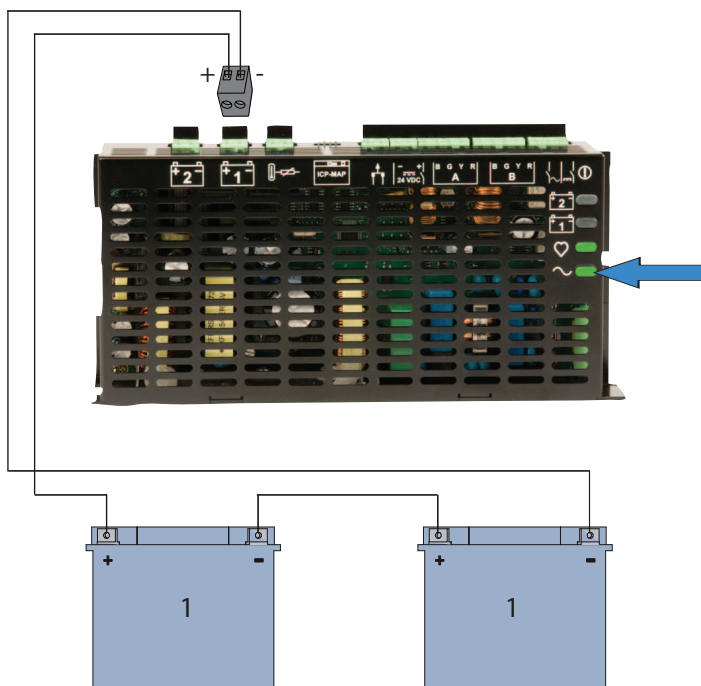



Figure 6.1: Connecting the batteries



Danger!

Battery

Injuries due to electric shock, fire or explosion are possible if the battery is handled or connected incorrectly.

- Always handle the battery carefully and replace it carefully.
- Make sure that the grounding terminal is always connected and that N, L or  are connected correctly.
- Make sure to first disconnect the positive wire of the battery when removing it from the system.
- Be careful when connecting the positive (red) wire and the "BATT +" port of the system. Make sure not to short-circuit with the "BATT +" port to prevent electric arc from occurring.

6.2 Programming

Programming instructions for the EMIL expansion module in RPS for MAP

Device	Name	Property	
EMIL expansion module	NEV 400	Use Coupler Tamper Switch = No	
Input	Name	Point Type	Input Mode
PL 1	Main Power Failure	Trouble (bypassable, non-latching)	Single EOL (12k1)
PL 2	Battery Power Failure	Trouble (bypassable, latching)	Single EOL (12k1)
PL 3*	Fuse Failure	Trouble (bypassable, latching)	Single EOL (12k1)
PL 4	Tamper	Tamper Switch	Contact Line
PL 5	free		
PL 6	free		
Output	Name	Output Type	Output Behavior
S 1*	LED Main Power Failure	LED	Activate Output 1 on Input 1
S 2*	LED Battery Power Failure	LED	Activate Output 2 on Input 2

S 3*	LED Fuse Failure	LED	Activate Output 3 on Input 3
S 4	free		

* optional

Programming instructions for the EMIL expansion module in Winpara

Input	Short Info	Message Type	Mode	ES armed	ES disarmed
EMIL expansion module	NEV 400		Tamper Switch	05	05
PL 1	Mains Failure	Intrusion	with Tamper detection = No	94	94
PL 2	Battery Failure	Intrusion	with Tamper detection = No	95	95
PL 3*	Fuse Failure	Intrusion	with Tamper detection = No	28	28
PL 4	Tamper	Input	NA	19 (open)	05 (closed)
PL 5	--	free			

PL 6	--	free			
Output		Output Behavior			
LED1*	NA	Activate LED 1 when PL1 triggered			
LED2*	NA	Activate LED 2 when PL2 triggered			
Cpoint*	NA	Activate Cpoint when PL3 triggered			
BSM	free				

* optional

Programming instructions for the EMIL expansion module in NZpara and MAP2para

Element	Text	Message Type	Control Status	Parameter	Driven Output
EMIL expansion module	NEV 400	Use Coupler Tamper Switch = No			
PL 1	Mains Failure	Malfunction Power		Standard	EMIL-OUT1*

PL 2	Battery Failure	Malfunction		Standard	EMIL-OUT2*
PL 3*	Fuse Failure	Malfunction		Standard	EMIL-OUT3*
PL 4	Tamper	Sabotage		Contact Input	None
PL 5	free	free			
PL 6	free	free			
OUT1*			General Malfunction	Restoral Off	
OUT2*			General Malfunction	Restoral Off	
OUT3*			General Malfunction	Restoral Off	
OUT4	free				

* optional

7 Troubleshooting

Problem	Reason	Solution
BATT 1 indicator is on	Battery is missing	Check battery Connect battery or replace battery
BATT 1 indicator is blinking	Battery low	Check battery Wait for battery to charge
Heartbeat indicator not flashing anymore	Power supply is missing	Check power supply Replace power supply if necessary
AC indicator off	230 V missing Mains power missing	Check the fuses

8 Maintenance

Maintenance and inspection work must be carried out at defined intervals and by corresponding expert personnel. The regulations of DIN VDE 0833 apply additionally for all work of this kind.



Danger!

Electricity

Injuries due to electricity are possible if the system is not operated correctly or if the system is opened or modified not accordingly to this manual.

-
- To switch off the power, make sure to have a circuit breaker available.
 - Ensure that the system is switched off during the installation, wiring and maintenance process.
 - Only open or modify the system accordingly to this manual.
 - Ensure to connect the system to the electric supply with a protective grounding contact.
 - Only qualified installers/service personnel are allowed to install and maintain this system.



Caution!

Maintenance

Damage or malfunction of the system is possible if it is not maintained on a regular basis.

-
- Ensure to get the system maintained once a year.
 - Only qualified installers/service personnel are allowed to maintain this system.

9 Technical data

Electrical

Rated voltage in VDC	28 ± 1
Minimum operating voltage in VDC	26
Maximum operating voltage in VDC	30
Minimum output voltage in VDC	24
Maximum output voltage in VDC	30
Rated current in mA	500 mA
Maximum output current in A (A or B)	2
Maximum output current in A (A and B)	3
AC failure detection delay	10 min
Battery ampere hour rating	2 x 12 V / 18 Ah

Mechanical

Dimension in cm (H x W x D)	43,6 x 44,3 x 11,2
-----------------------------	--------------------

Environmental

Environmental class	II
Protection class	IP30



Bosch Security Systems B.V.

Torenallee 49
5617 BA Eindhoven
Netherlands

www.boschsecurity.com

© Bosch Security Systems B.V., 2019