

THIS COPY IS PROVIDED ON A RESTRICTED BASIS AND IS NOT TO BE USED IN ANY WAY DETRIMENTAL TO THE INTERESTS OF PANDUIT CORP.

NOTES:

1. SEE CURRENT CATALOG FOR ADDITIONAL P/N SUFFIXES TO INDICATE PACKAGE QUANTITY.
2. ALL 8 POSITION, 8 WIRE CONNECTOR MODULES ARE UNIVERSAL IN DESIGN. THEY WILL ACCEPT TWO, THREE, OR FOUR PAIR MODULE PLUGS WITHOUT DAMAGE.
3. DIMENSIONS IN PARENTHESES ARE METRIC
4. MOUNTS IN COMMON NEMA 1-13/64" (30.5mm) DIAMETER ENCLOSURE OPENING.
5. MOUNTS IN PANEL THICKNESS OF .035-.135"
6. SEALS TO IP67.

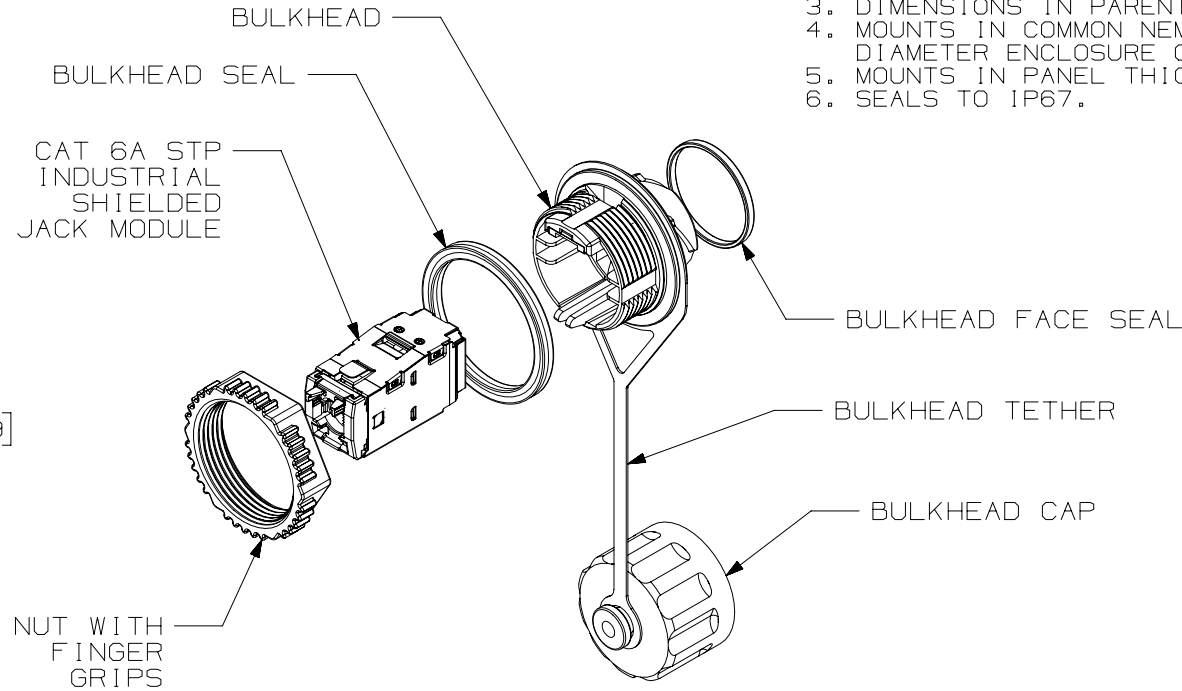
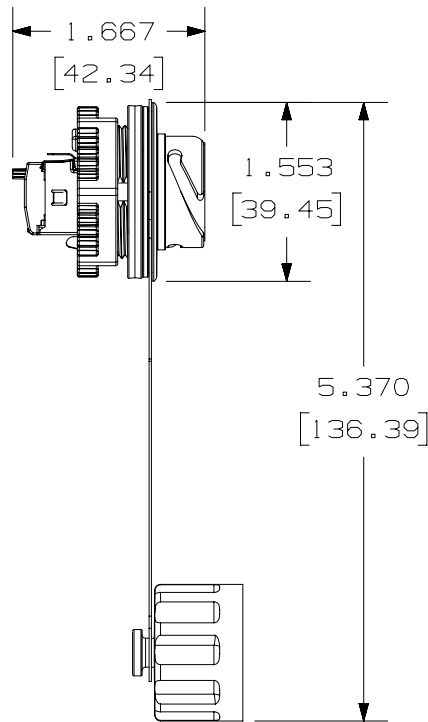

PART NUMBER 1AEBH6XS		PRODUCT SPEC/PKG SPEC N/A	
I.I. NUMBER N/A		WORK INSTRUCTION N/A	
TITLE INDUSTRIAL TX6A CONNECTOR SHIELDED JACK MODULE WITH BULKHEAD CUSTOMER DRAWING			
ITEM REVISION NAME 00251NAB/00		PANDUIT	
DATASET FILE NAME 00251NAB_DC02/00A			
UNLESS OTHERWISE SPECIFIED, DIMENSIONAL TOLERANCES ARE: IN [mm]		MATERIAL: SEE BOM	
.x ± .xx ± .03 [.8]		.xxx ± .010 [.3] ANGLES ±	
DRAWN BY BJN		DRAWING NUMBER: 00251NAB-02	
DATE 5-5-16		THIRD ANGLE PROJECTION	
CHK JAV		SCALE NONE	
SHT 1 OF 1		SIZE A	

REV	DATE	BY	CHK	APR	DESCRIPTION	ECN
R	7-21-16	BJN	JAV	MBVE	RELEASED TO PRODUCTION	00251NAB-02

D10100DA/14