

THIS COPY IS PROVIDED ON A RESTRICTED BASIS AND IS NOT TO BE USED IN ANY WAY DETRIMENTAL TO THE INTERESTS OF PANDUIT CORP.

PANDUIT P/N	WEIGHT
NK4MFL**	.25 LB/10 PCS (114 g/10 PCS)

NOTES:

- SEE CURRENT CATALOG FOR ADDITIONAL PART SUFFIXES TO INDICATE COLOR AND OR PACKAGE QUANTITY.
- FACEPLATE ACCEPTS FOUR NETKEY MODULES.
- FURNITURE CUTOUT REQUIREMENT IS 2.673" TO 2.750" BY 1.345" TO 1.405".
- DIMENSIONS IN () ARE IN METRIC.
- PART INCLUDES:
1-FACEPLATE
1-LABEL
1-LABEL COVER

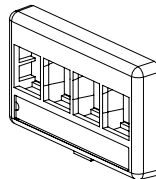
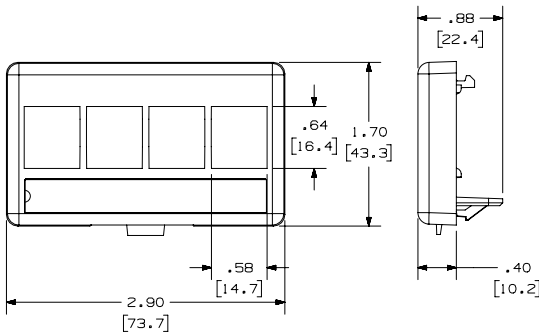

PART NUMBER		NK4MFL**	
TITLE			
NETKEY 4 POSITION MODULAR FURNITURE FACEPLATE WITH LABEL POCKET			
CUSTOMER DRAWING			
ITEM REVISION NAME		00996NCE/05	
DATASET FILE NAME		00996NCE_DC/05A	
UNLESS OTHERWISE SPECIFIED, DIMENSIONAL TOLERANCES ARE: IN [mm]		MATERIAL:	
.X ± .XXX ± .010 (.3)		ABS	
.XX ± .03 (.8)		DRAWING NUMBER:	
THIRD ANGLE PROJECTION		00096NCE - DC	
DRAWN BY	DATE	CHK	SCALE
MDJR	04-03-20	RJJC	NONE
DESCRIPTION			SIZE
SHT 1 OF 1			A

REV	DATE	BY	CHK	APR	DESCRIPTION	ECN
05A	04/24/20	MDJR	RJJC	SKH	RELEASED TO PRODUCTION	00996NCE-DC