

Control
number

2013-9E-012

To VDI GROUP SA

SPECIFICATION
VANADIUM LITHIUM RECHARGEABLE BATTERY
Ordering Code : VL-2020/VCN
Model Code : VL2020

Approved by
Division/Department
Name
Title
Signature/date



Issued : Apr,2,2013

Energy Device Business Division
Automotive & Industrial Systems Company
Panasonic Corporation

Approved	Checked	Checked	Drafted
<i>E. Nanno</i>	<i>Y. Inoue</i>	<i>S. Kawaguchi</i>	<i>T. Wata</i>

Change Record

No.	Date	Revision
1	Apr,2,2013	Issued
2		
3		
4		
5		
6		
7		
8		
9		
10		
11		
12		
13		
14		
15		
16		

1.Scope

This specification applies to the VANADIUM LITHIUM rechargeable battery which are delivered from Automotive & Industrial Systems Company.

2.General specification

Items	Contents	Remarks
Model code	VL2020	
Nominal voltage	3V	
Nominal capacity	20mAh	Cut off voltage : 2.5V
Recommended drain current	less than 70 μ A	For memory back up use
Cycle life	50 cycles 1000 cycles	100%D.O.D. Cycle(*1) 10%D.O.D. Cycle(*1)
Charge		
Charge method	Constant voltage charge	Trickle charge prohibited
Charge voltage	3.25~3.55V	
Charge current	less than 1.5mA	At 3.0V of the battery voltage (Refer to Item 6)
Operating temperature	-20 to 60°C	
Recommended storage condition	Temp.; 10 to 30°C Humidity; less than 60%R.H.	
Dimension&Configuration	Refer to attached figure	
Mass	approx. 2.2g	Bare cell
UL standard	File No. MH12210	

(*1) ; D.O.D. : Depth Of Discharge of nominal capacity

3. Characteristics and test methods

3.1. Open circuit voltage

After storage in measuring atmosphere($20 \pm 2^\circ\text{C}$) for at least 2 hours, this shall be measured with voltage meter described in Item 4.3.(1).

Open circuit voltage should conform to the following value.

When delivered: 2.95~3.50V

3.2. Internal resistance

After storage in measuring atmosphere($20 \pm 2^\circ\text{C}$) for at least 2 hours, this shall be measured with resistance meter described in Item 4.3.(2).

Internal resistance should conform to the following value.

Initial: less than 30 Ω

3.3. Discharge capacity

Initial and after storage, the batteries are to be discharged with 30k Ω load resistance (approx.100 μ A) to 2.5V, the discharge capacity should conform to the values shown in Table.1.

*Initially the batteries are to be charged by standard method as Item 6.

*After storage, the batteries are discharged without charge.

Table.1 Guaranteed capacity

Temperature	Initial	Storage period at 60°C	
		20days	40days
$20 \pm 2^\circ\text{C}$	more than 22.5mAh	more than 21.3mAh	more than 20.2mAh
$60 \pm 2^\circ\text{C}$	more than 22.5mAh	—	—
$-20 \pm 2^\circ\text{C}$	more than 18mAh	—	—

3.4. Charge-discharge cycle characteristics

3.4.1. Charge-discharge cycle characteristics-1 (100%D.O.D. cycle)

Charge condition:	Charge voltage	3.4V
	Protective resistance	200 Ω
	Charge time	24h
Discharge condition:	Load resistance	3k Ω
	Discharge time	20h
	(The capacity at initial cycle : 18~20mAh)	
Temperature	20 ± 2°C	

In above condition, the battery should satisfy 40cycles until down to 50% of the initial cycle capacity.

3.4.2. Charge-discharge cycle characteristics-2 (10%D.O.D. cycle)

(Before the cycle test, the battery is discharged to less than 1.0V, then charged by standard method as Item 6 at room temperature.)

Charge condition:	Charge voltage	3.4V
	Protective resistance	100 Ω
	Charge time	2h
Discharge condition:	Load resistance	3k Ω
	Discharge time	2h
	(The capacity at initial cycle : 1.8~2.0mAh)	
Temperature	20 ± 2°C	

In above condition, the battery should satisfy 800cycles until down to 50% of the initial cycle capacity.

3.5. Overcharge characteristics

After continuous charging for 20 days at 60°C in the standard charging circuit as Item 6, the battery is to be tested according to the test method shown in Item.3.3 at 20 ± 2°C.

The capacity should be more than 20.2mAh.

3.6. Overdischarge characteristics

After discharge with 3k Ω load for 20 days at 20°C, the battery is to be charged by standard condition as Item 6 and is to be tested according to the test method shown in Item.3.3 at 20 ± 2°C.

The capacity should be more than 20.2mAh.

3.7. Leakage resistance

There must not be leakage that exerts a bad influence for the equipment after keeping the battery for 30 days at 60 ± 2°C and 90 ± 5%R.H.

3.8. Drop shock test

The battery should have mechanically and electrically normal characteristics after the following drop test. The battery is dropped from 750mm(29.53inches) height to the lauan board with 30mm thickness having subjected axis respectively 10 times.

(without tab terminals)

3.9. Vibration test

The battery should have mechanically and electrically normal characteristics after the following vibration test. The test condition is 16.7Hz with an amplitude of 2mm in the X, Y, and Z directions for 30 minutes.

(without tab terminals)

3.10. Appearance

No deformation, bruise and stain which cause practical interference.

3.11. External dimensions

This shall be measured with measurement equipments described in Item 4.3.(5).

Measure the battery by placing a thin insulating paper not to be short-circuited.

Dimensions should conform to the attached figure.

4. Test conditions

4.1. Test timing

Within a month from delivered day.

4.2. Temperature and humidity

Unless otherwise specified, the tests are to be carried out in room temperature $20 \pm 15^{\circ}\text{C}$ and relative humidity $65 \pm 20\%$.

4.3. Means of measurement

- (1) Voltage meter defined by JIS C1102 class 0.2 or higher, and more than $10\text{M}\Omega$ impedance must be used.
- (2) Internal resistance should be measured by sinusoidal current method(1kHz). Measurement should be finished within 5 seconds.
(As a general, Agilent Technologies LCRmeter No. 4263B or equivalent should be used.)
- (3) Load resistance includes all resistances of discharge circuit, and tolerance is less than 0.5%.
- (4) Visual inspection is carried out by naked eyes.
- (5) Micrometer defined by JIS B7502 or equivalent or more accurate one must be used for dimension measurement.
For one digit decimals tolerance, measurement tools with 0.05mm accuracy which is defined JIS B7507 or higher accuracy equipment must be used.

5. Indication and Production Site

5.1. Indication

Below items are indicated on battery.

Model code	VL2020
Plus polarity	+
Manufacturer or its brand :	Panasonic
Production country	Made in Indonesia

(Design of indication can be changed without notice.)

5.2. Production Site PT.Panasonic Gobel Energy Indonesia

Jl. Teuku Umar Km.44 Chikarang Barat,Bekasi 17520, Jawa Barat, Indonesia

6. Charge

6.1. Standard recommended charge circuit

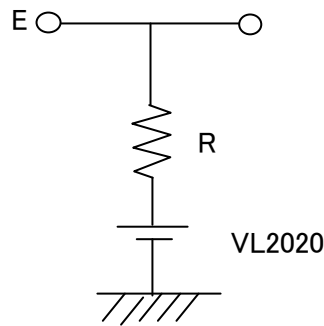

Charge voltage (E)	3.4V
Protective resistance (R)	200 Ω
Charge time	24h

VL2020 Charging curve

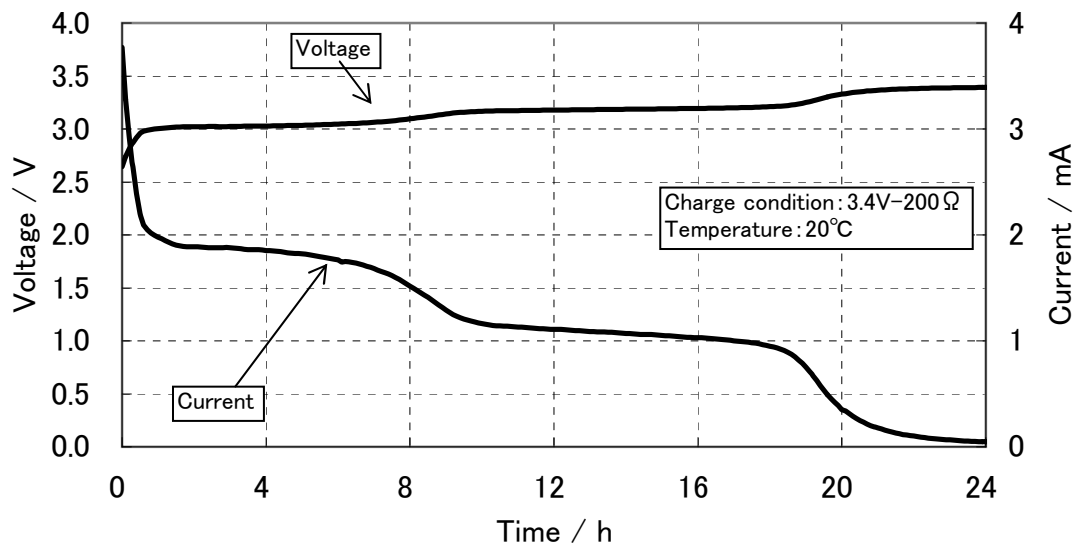

6.2. Charge circuit for memory back up use

(1) Charge conditions are as below.

- * Charge method : Constant voltage charge
- * Charge voltage : 3.25~3.55V (standard voltage: 3.4V)
- * Charge current : Less than 1.5mA at 3.0V of battery voltage
- * Be sure to design the charge circuit such that it will keep charging the back up battery (=VL) when the main power switch is off.

If the power supply is shut down and the battery is discharged, the life of the battery will be reduced after repeating the electrical charge and discharge. (It depends on the conditions of the device.)

(2) Please refer to example of circuits.

To ensure long and trouble-free service, be sure to specify your operating conditions and crucial parameters in advance.

7. Operation and modification of this specification

Modification must be carried out under mutual agreement.

Any accidents caused by non-described items in this specifications must be discussed and solved mutually.

8. Important Notes (Warranty)

- (1)The batteries are warranted to conform to the descriptions contained in this Specifications for a period of twelve(12) months from the ex-factory date. In the event that a Battery fails to comply with the Specifications and the cause of which was attributable to Panasonic Corporation AIS Company's fault during the said warranty period, Panasonic Corporation AIS Company will supply a replacement Battery.
- (2)Please assure full responsibility for matching and reliability of Batteries on actual set or unit application.
- (3)Panasonic Corporation AIS Company's warranty shall not be applicable in the case where customer fails to carry out proper handling, operating, installation, testing, service and check out of the Batteries and/or to follow the instructions, cautions, warnings, notes provided in this specifications, or other reasonable methods.
- (4)When this specification is not returned until either 6 months from specification issued date or first delivery date whichever comes first, this specification is deemed to be approved by customer.

9. Precautions for use

9.1. Storage precautions

A battery shall not be stored at high temperature.

Storage condition shall be from 10 to 30°C with package.

Storage at less than 0°C can deform the plastic parts and may cause a leakage.

To prevent self-discharge caused by corrosion or decrease of insulation, humidity during storage shall be less than 60%R.H. without dewing on battery.

9.2. Operation temperature

Operating temperatures range is from -20 to 60°C.

Even if temperature goes temporarily beyond this range, the batteries do not deteriorate greatly in performance. However, the extended operation or storage at temperature exceeding 60°C may reduce battery performance.

9.3. Soldering

Do not solder anything directly to the battery.

*Battery with tab terminals

An automatic solder dip tank can be used for soldering provided each dip time is limited to 5 seconds and within twice dipping. Since the battery is temporarily short-circuited during soldering, charge it as specified before testing.

When soldering manually, do so within 5 seconds (solder iron temperature approx. 350°C).

In both cases, make sure that the battery surface temperature doesn't exceed 85°C.

And, avoid dust, foreign matter and heat dissipating parts.

9.4. Short-circuit

Do not cause short-circuits, except when dipped in the solder tank.

In addition, never attempt to insert the battery into any conductive mat or wrap it together with a Printed plate.

9.5. Please do not connect the batteries in series. (If you need, be sure to consult us.)

9.6. Please consult us about parallel connection application.

10. Prohibitions : Never attempt the following

* Never disassemble the battery.

The organic electrolyte inside the battery is harmful to skin.

* Never throw the battery into fire and water.

If thrown into fire, the battery may explode. If thrown into water, it will lose function.

* Never reverse the polarity (+) and (-).

Reversing the polarity causes deterioration of function.

* Never use different types of battery together.

Avoid using this battery and an ordinary coin-type lithium battery, old and new batteries, any other combination of rechargeable batteries. Differences in characteristics may cause damage to the battery as well as to the equipment.

* Never pack batteries together

Batteries may make short-circuit by themselves, then reducing their life.

【Your Operation Condition (Circuit diagram)】

Maintain the base conditions as below. Otherwise, battery quality may be damaged.
Other than the base conditions, use at your own risk.

Base conditions : Charge voltage : 3.25~3.55V

Charge current : Below approximate 1.5mA at 3.0V of battery voltage

If you have any questions, please contact Panasonic.

【Reference】 Example of Charging Circuits

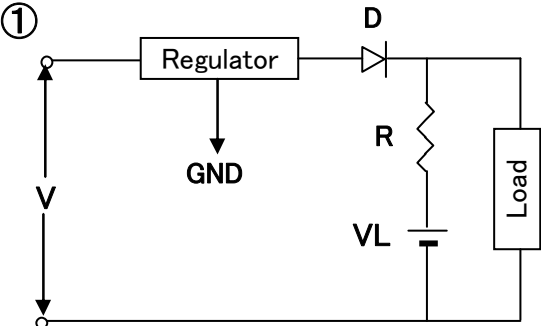
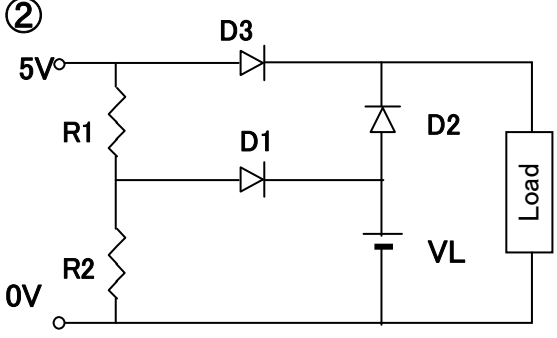
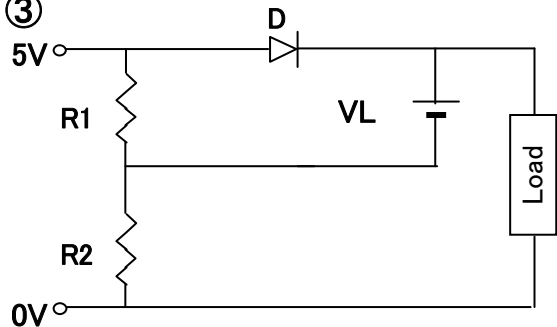
<p>①</p> 	<p>Standard Circuit</p> <table border="1" data-bbox="837 1019 1257 1120"> <thead> <tr> <th>Reg.</th> <th>D</th> <th>R</th> </tr> </thead> <tbody> <tr> <td>3.5V</td> <td>DB2J314</td> <td>240 Ω</td> </tr> <tr> <td>3.4V</td> <td>DB2J314</td> <td>180 Ω</td> </tr> </tbody> </table>	Reg.	D	R	3.5V	DB2J314	240 Ω	3.4V	DB2J314	180 Ω
Reg.	D	R								
3.5V	DB2J314	240 Ω								
3.4V	DB2J314	180 Ω								
<p>②</p> 	<p><u>Standard Circuit (Charging from 5V line)</u></p> <p>Resistance R1=240 Ω、 R2=590 Ω</p> <p>Diode D : DB2J314 (Very small reverse current)</p> <p>For diode D2, select a diode of small inverse current ($I_p = 1 \mu A$ below / 5V)</p>									
<p>③</p> 	<p><u>Cost performance type</u></p> <p>During Charging, there is voltage drop V_f at D.</p> <p>Diode D : DB2J314 (Very small reverse current)</p> <p>In case the current flows through D is less than 1mA, when the battery is full charged ($V_f=0\sim 0.3V$)</p> <p>Resistance R1=590 Ω、 R2=240 Ω</p> <p>※If the current excesses 1mA, these value of resistances is different.</p>									

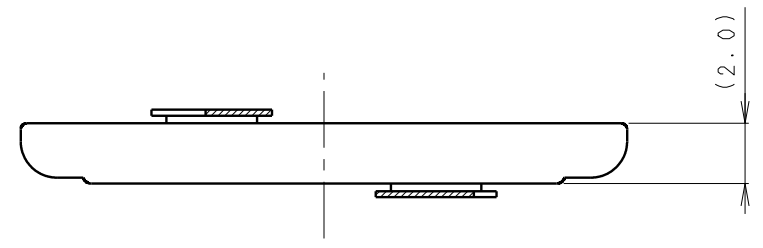
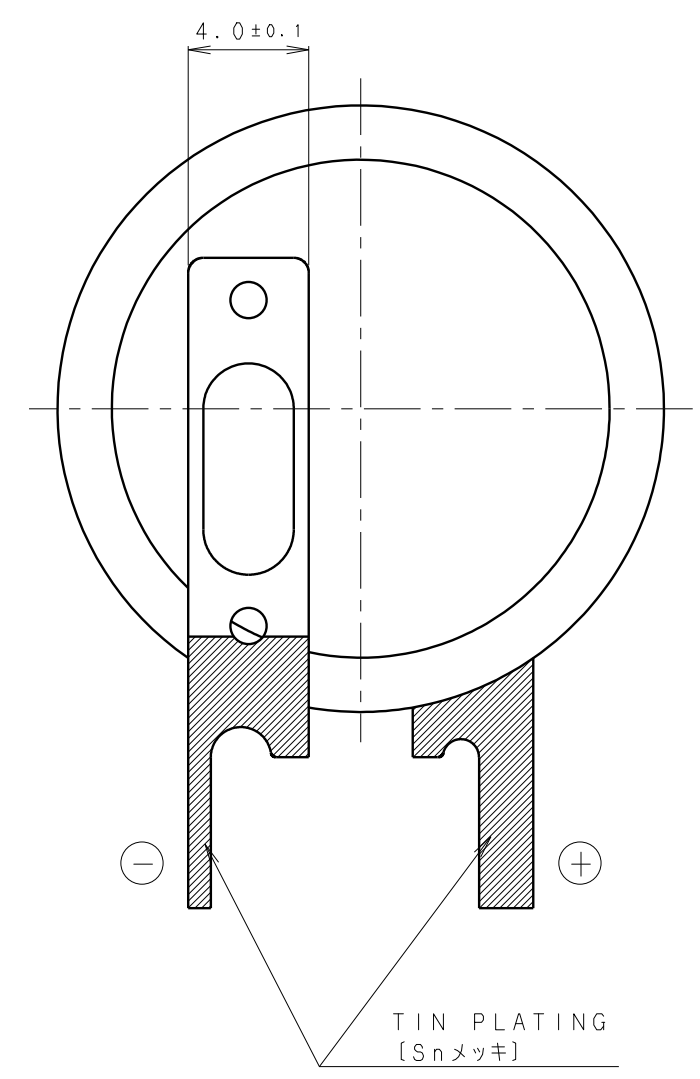
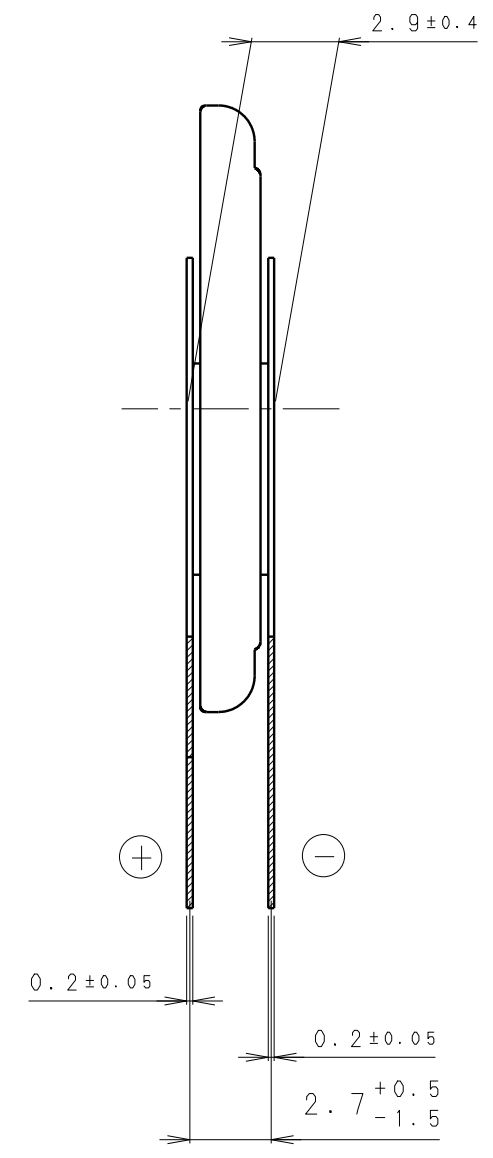
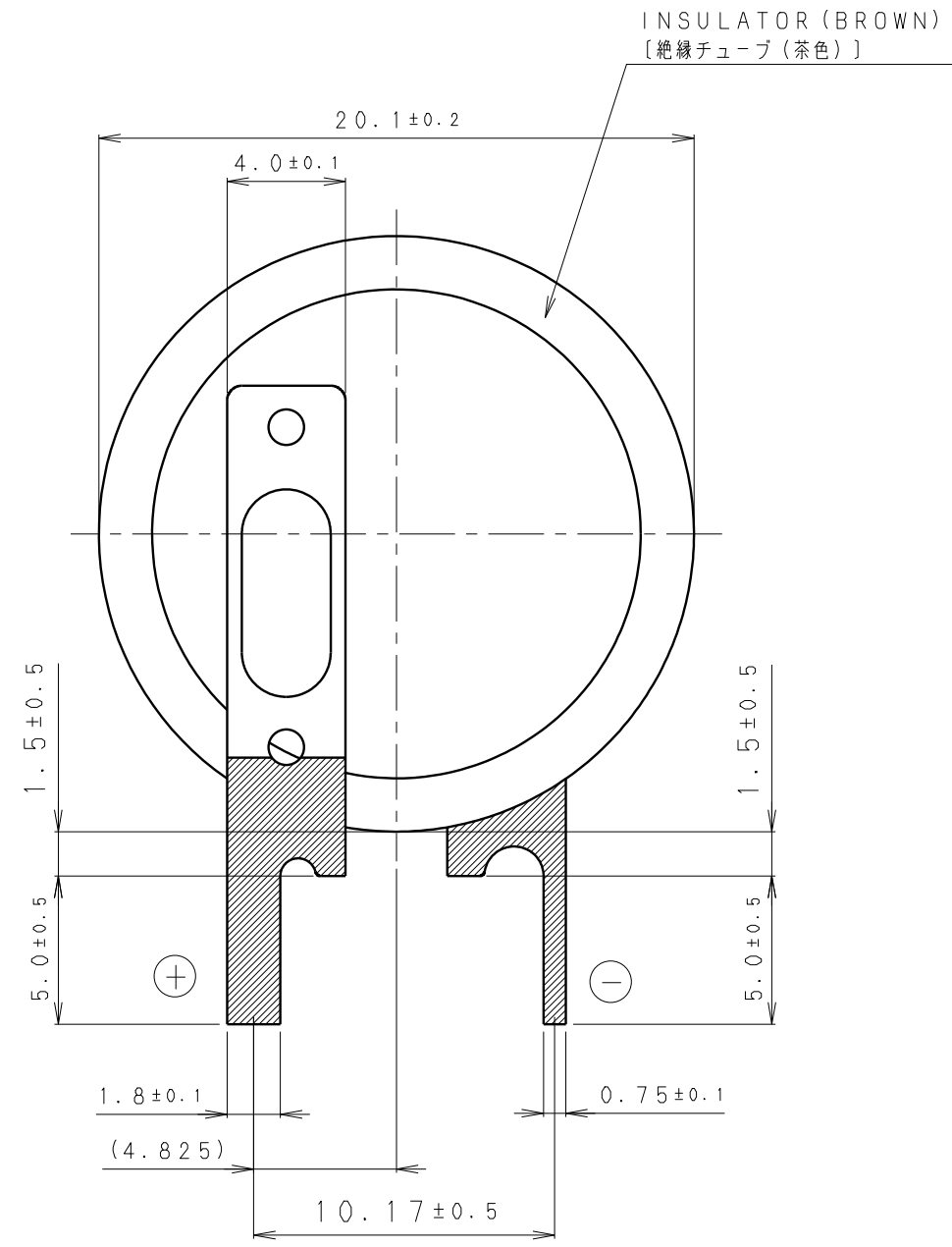

NOTE [注記]

1. TAB WELDING STRENGTH OVER 19.6N [端子溶接強度:19.6N以上]
2. TAB MATERIAL: STAINLESS STEEL WITH TIN PLATING [端子材料: 基材 ステンレス/表面 部分Snメッキ]
3. (): REFERENCE DIMENSION AND ANGLE [() 寸法、角度は参考値]

PRODUCT NO.	VL-2020/VCN	SCALE	UNIT:mm
		4:1	
DRAWING NO.	PEVA1Z	REV.	0

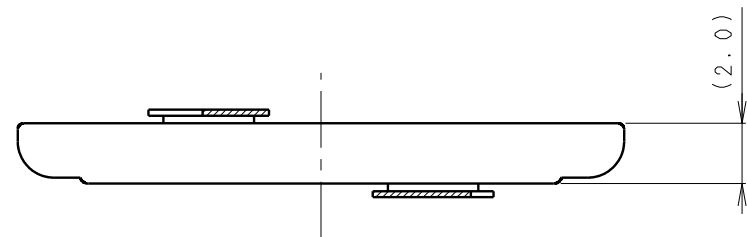
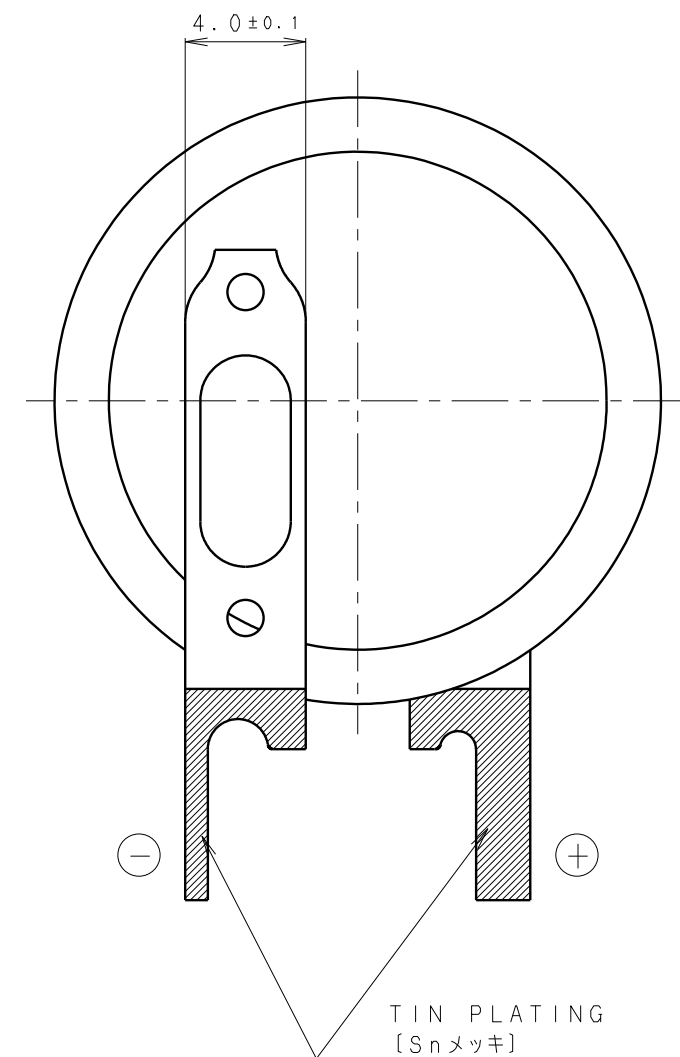
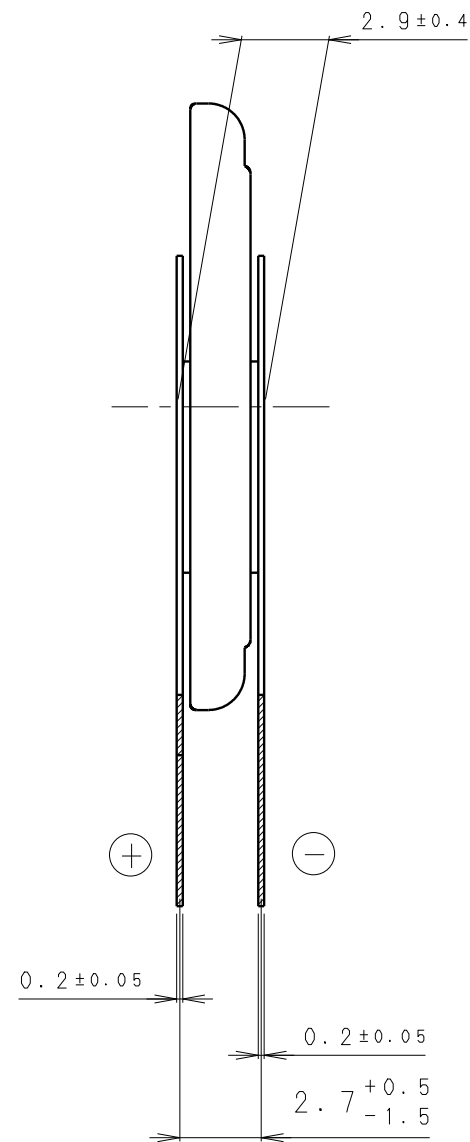
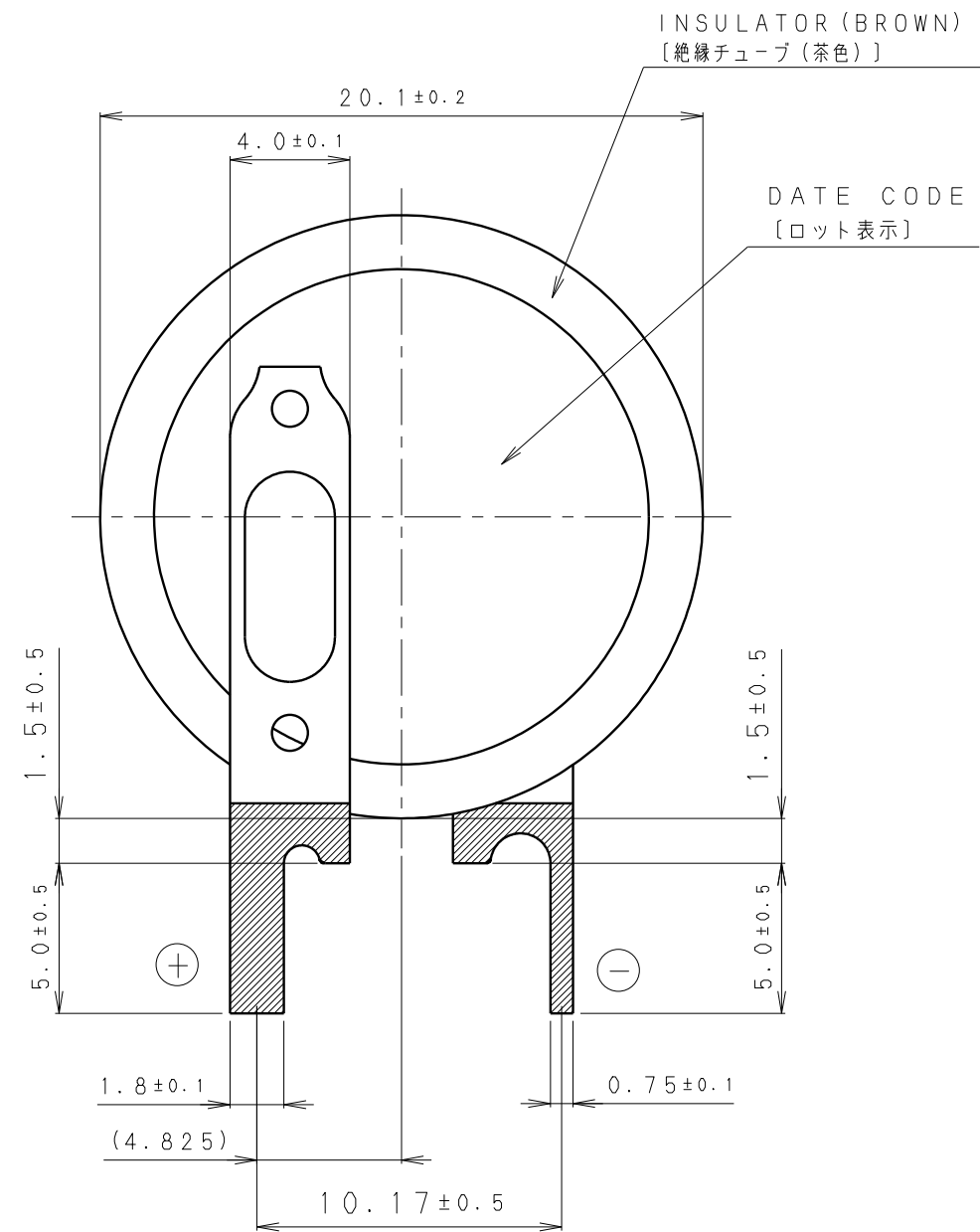

NOTE [注記]

- TAB WELDING STRENGTH OVER 19.6N [端子溶接強度:19.6N以上]
- TAB MATERIAL: STAINLESS STEEL WITH TIN PLATING [端子材料:基材 ステンレス/表面 部分Snメッキ]
- (): REFERENCE DIMENSION AND ANGLE [() 寸法、角度は参考値]

PRODUCT NO.	VL-2020/VCN		SCALE
			4:1
DRAWING NO.	PEVA1Z	REV.	UNIT:mm
		PC_0	

Packaging Specification

Drawing Number

232-C17-005G_A

Lithium battery with tab

Tray for 20pcs.×Inner Sleeve for 120pcs.×Outer Carton for 480pcs.

1-Product

Refer to the product drawing

2-Tray for 20pcs.

*The battery shape is different by product number

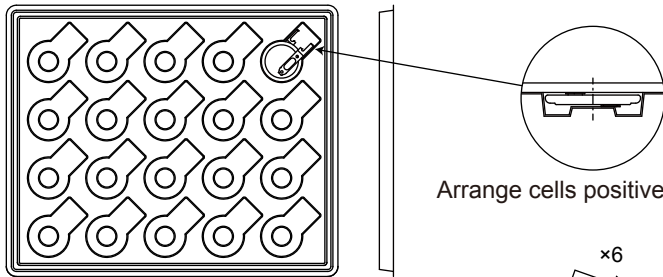

Arrange cells positive side up

x6

3-Inner Sleeve for 120pcs.

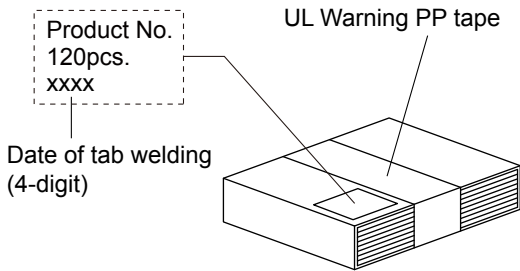

UL Warning PP tape

Product No.
120pcs.
xxxx

Date of tab welding
(4-digit)

x4

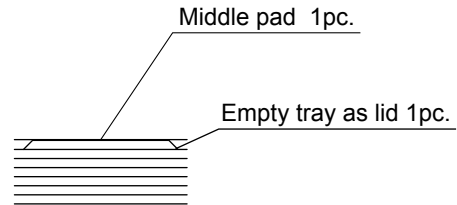

Middle pad 1pc.

Empty tray as lid 1pc.

4-Outer Carton for 480pcs.

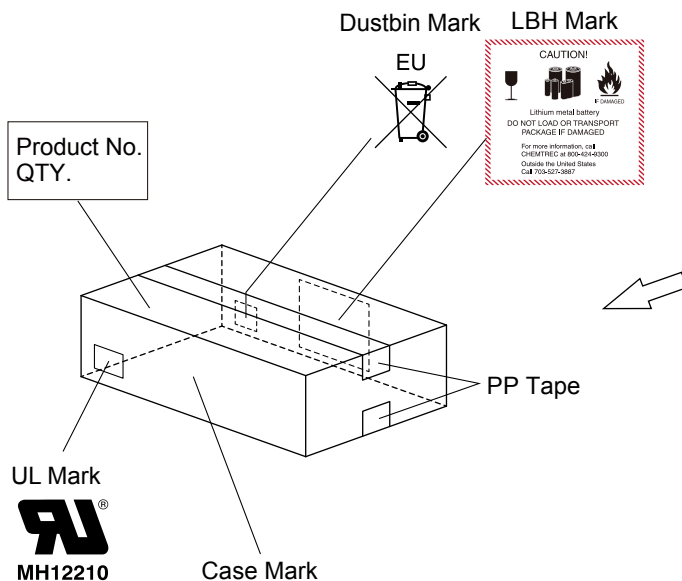

Dustbin Mark

LBH Mark

EU

Product No.
QTY.



CAUTION!
Lithium metal battery
DO NOT LOAD OR TRANSPORT
PACKAGE IF DAMAGED
For more information, call
CHEMTRAC at 800-424-6300
Outside the United States,
Call 708-527-3887

PP Tape

UL Mark

MH12210

Case Mark

Alignment

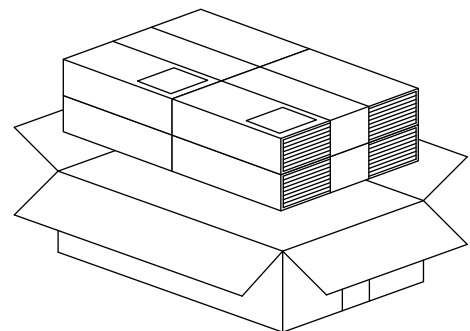

※ Fill the space with the buffer material

Packing List

Dimension : 198×291×132mm
M3 : 0.0076m³
Net : 1.20kg
Gross : 1.93kg

Precautions for Handling Vanadium Lithium Secondary Batteries (VL Series)

Be sure to observe the following safety precautions using vanadium lithium secondary batteries.

1. Charging Voltage Range

When using the constant-voltage charge method, observe the specified value of the charging voltage.

The specified (guaranteed) value when the operating temperature ranges from -20°C to 60°C is $3.4\pm 0.15\text{V}$. (The actual capability is $3.4\pm 0.20\text{V}$.)

- When the charging voltage exceeds the upper specified limit, the battery internal resistance may increase causing premature deterioration, thus possibly shortening battery life. In the vicinity of 4V, the + terminal (case) may corrode, resulting in possible battery leakage. (Please see the back.)
- When the charging voltage is less than the lower specified limit, a 100% battery capacity recovery is not possible.

When using the constant-current charge method, be sure to observe the specified charging current and design a circuit whereby the battery charging voltage never exceeds the allowable limit.

2. Trickle Charge

Avoid using a trickle charger designed for charging nickel-cadmium battery as shown at right. This type of battery charger has a peak charging of upto 5 V, which may possibly shorten the battery life.

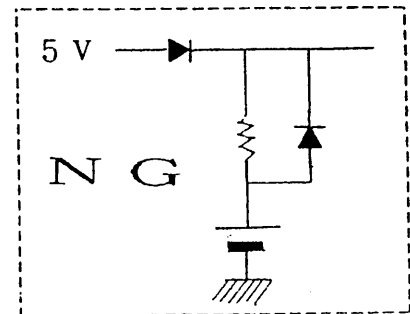

3. Batteries Connected in Series

Be sure to consult us first before connecting more than one battery in series.

4. Improper Alignment of the (+) and (-) Terminals

The (-) terminal (sealing plate) can corrode, causing battery leakage and possible equipment damage.

5. Mixed Use of Different Batteries

Do not use a lithium primary battery and any other secondary battery, or the new and old batteries of the same kind together. Differences in voltage and electric capacity may cause the batteries to deteriorate resulting in possible equipment damage.

6. Soldering

Direct soldering to the battery can cause damage to the resin materials such as the gasket and/or the separator due to heat, resulting in leakage and/or possible explosion. Automatic soldering makes usual solder dipping possible, but solder reflowing remains impossible.

7. Others

Never throw batteries into a fire, subject them to heat in excess of 100°C or attempt any disassembly of them as this is extremely dangerous.

Effect of Charging Voltage on Vanadium Lithium Secondary Batteries (VL Series)

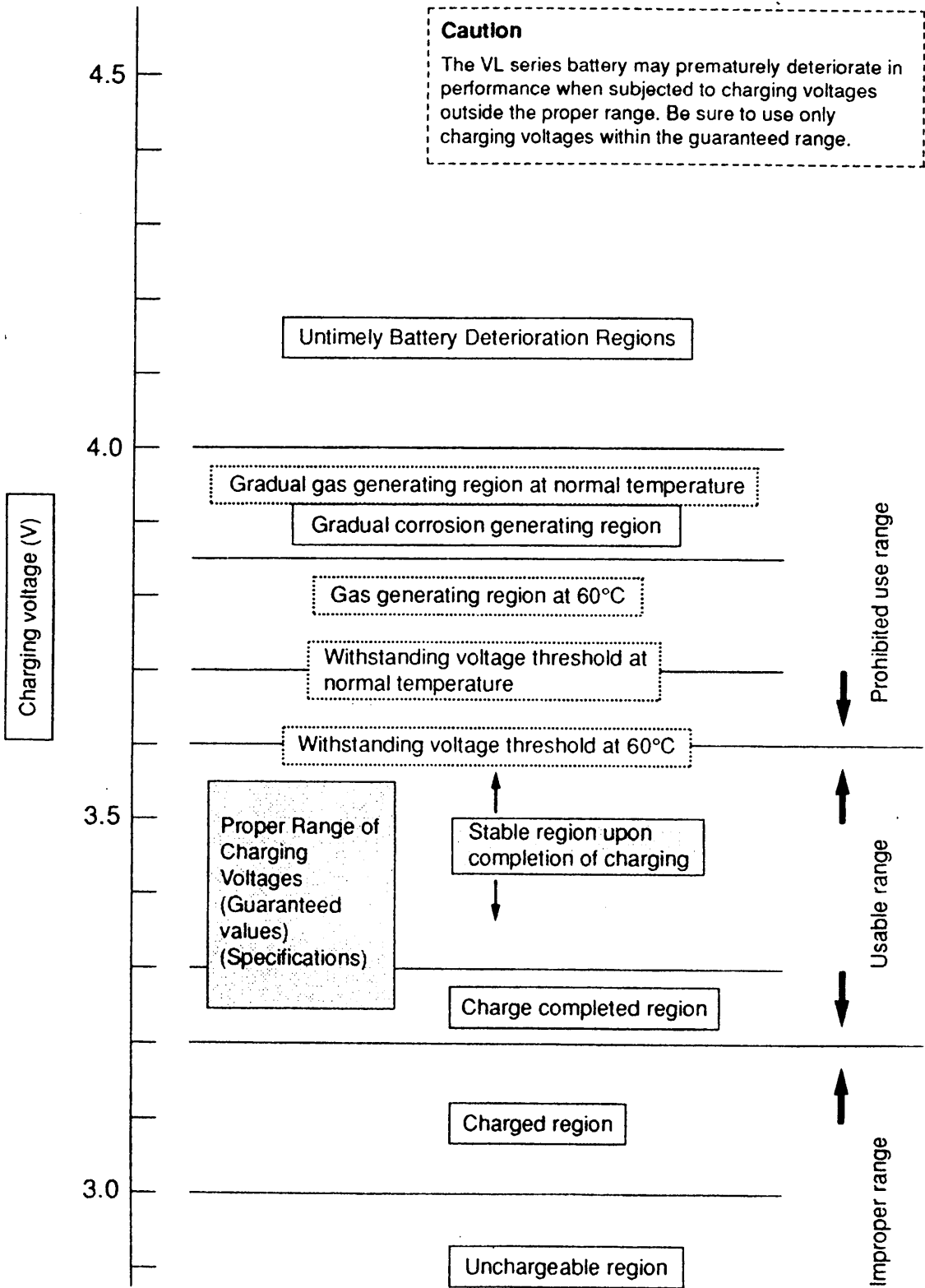

Battery Safety Practices

Avoiding hazards in lithium battery handling



Warning

Mishandling batteries can cause battery leakage, heat generation, rupture, ignition etc., that can lead to possible fire or injury.

Both of coin type and cylinder type of lithium batteries contain flammable materials such as lithium, organic solvent and other chemical ingredients. Improper handling of lithium batteries may result in heat generation, fire or explosion, with a risk of personal injury or damage. To prevent these accidents in battery handling, be sure to observe the following precautions.

1. Do not Short circuit

Direct connection of plus(+) and minus(-) poles may result in leakage, heat generation, explosion and/or fire.

Do not store and/or carry batteries with metallic product such as necklace. (Refer fig.1)

Fig. 1 Short circuit

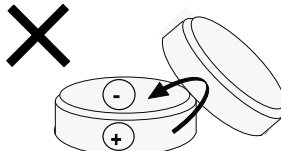

Fig. 2 stacked & jumble batteries



2. Do not stack and/or jumble batteries

Stacked and/or jumbled batteries may cause short circuit and/or forced discharge by the contact of other batteries. This may result in leakage, heat generation, explosion and/or fire.

Especially, a connection with the 006P(9V) type batteries may have a high risk of leakage, heat generation, explosion and/or fire. (Refer fig.2 & 3)

3. Do not make forced discharge batteries

Forced discharge by external power source, the battery voltage goes to negative and this cause gas generation in inside of the battery. This may result in leakage, heat generation, explosion and/or fire. (Refer fig.3)

* In your disposal and/or storage of the batteries, please isolate plus and minus poles by adhesive tape. A connection with other metals and/or batteries may result in leakage, heat generation, explosion and/or fire.

* When using the stored battery, please remove the tape perfectly to avoid high contact resistance problem. (Refer fig.4)

4. Do not dispose of batteries in fire

Disposal of batteries in fire is extremely dangerous with a risk of explosion and violent flaring.

5. Do not heat batteries

Heating batteries above 100 (212°F) may damage the resin in crimping, separator and other parts, causing electrolyte leak, internal short circuit, fire and explosion.

6. Do not solder directly onto batteries

Direct soldering onto batteries may damage the resin in crimping, separator and other parts, causing electrolyte leak, internal short circuit, fire and explosion.

7. Do not charge batteries (For primary battery only)

Charging of primary batteries may result internal gas generation, causing electrolyte leak, battery swelling, fire and explosion.

8. Do not disassemble batteries

Disassembly batteries may cause gas generation that may irritate your throat. Lithium may also react with moisture to generate heat and fire.

9. Do not deform batteries

Applying extreme pressure to batteries may cause deformation of the crimping and internal short circuit, causing electrolyte leak, battery swelling, fire and explosion.

10. Do not mix different type batteries

For some applications, mixing of different type batteries, or new and old batteries, can cause over discharge due to differences in voltage and discharge capacities. This may lead to the risk of swelling and/or explosion.

11. Do not insert batteries with opposite polarity

For some applications, battery insertion with opposite polarity (reverse insertion of plus and minus) may result in leakage, heat generation, explosion and/or fire.

Please ensure the above precautions are strictly observed by related divisions including production departments, sales departments and external subcontractors. For additional details and information, please contact our sales representatives.

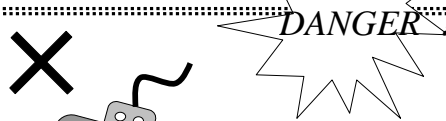
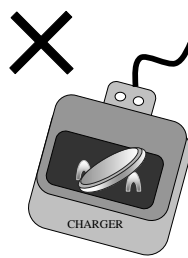

Fig. 3
Examples of forced discharge



Connection with battery charger

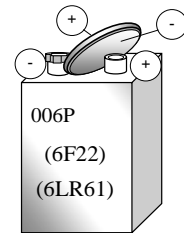
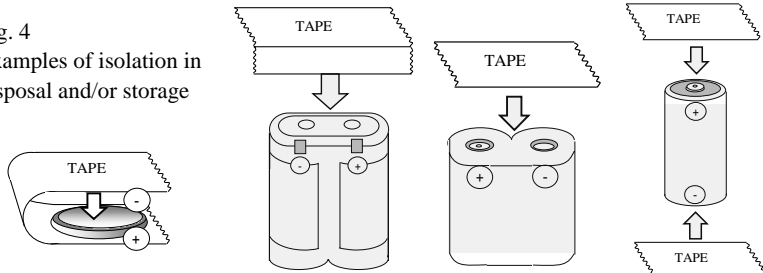

Fig. 4
Examples of isolation in disposal and/or storage



Beware of Antistatic Conductive Materials

Whenever terminal-mounted backup batteries or coin-type lithium batteries contact conductive materials, they discharge. Measures to protect semiconductor parts from static damage have been implemented in plants that use such ICs and LSIs. A number of protective materials are presently being used, and all contain blends of carbon, aluminum and other metals that make them conduct.

Antistatic conductive materials include packing bags, trays, mats, sheets, film and resin cases. Sheets, for example, have a resistance of 10^3 to $10^6 \Omega$, which means that when they contact the positive and negative terminals of a battery, they will discharge the battery.

In a lithium battery, a current flow of several μA to several mA reduces its voltage and electrical capacity. We recommend constant attention when using batteries around protective materials.

Examples

A terminal-mounted battery with its terminals inserted into a conductive mat is completely discharged after several days.

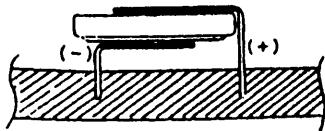

Conductive mat

A PCB-mounted battery is completely discharged by contact with the conductive resin case.

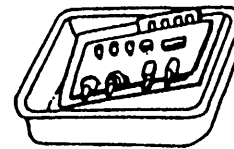

Conductive resin case

PCB-mounted batteries are discharged by contact with spacers and conductive rubber sheets.

Spacer

Conductive rubber sheet

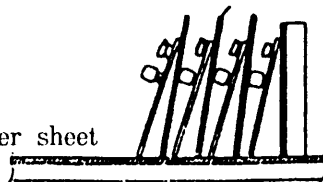

Batteries left on a work bench with positive and negative terminals in direct contact with the grounded rubber sheet cover are completely discharged.

Ground wire

Conductive sheet

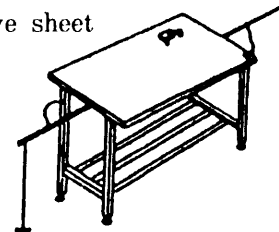

For more information, please make contact with your local dealer.

Precautions for Lithium Battery Soldering

When a lithium battery (with soldering tabs) is soldered to a PC board, the heat from soldering may damage the sealing gasket, possibly resulting in electrolyte leakage. Please observe the following precautions:

Precautions for Soldering

1. Never attempt reflow solder:

Reflow soldering should never be used for a lithium battery as it heats the battery body to a high temperature, possibly causing electrolyte leakage, performance degradation, or in the worst case, explosion or combustion.

2. Tab terminal soldering with a soldering iron:

Take care to keep the soldering iron from direct contact with the battery body. Limit soldering iron temperature to approx. 350°C, and finish soldering within 5 seconds.

3. Soldering in an automatic dip bath:

- While soldering in an automatic dip bath is allowable, the battery temperature should be limited to below 85°C throughout and after the dip process.
- Note that the battery temperature may exceed 85°C after the dip process due to residual heat within the dip machine.
- If the battery temperature exceeds 85°C, review the dip soldering environment and/ or dip time, or use forced cooling after the dip process.
- The basic limits on dip soldering are as follows:
 - Dip bath temperature = 260°C or below
 - Dip duration = 5 sec. or less
 - No. of dip cycles = 2 or less(If the battery temperature is expected to exceed 85°C, please consult us.)

Other Precautions

- Never attempt direct soldering on the battery body.
- Never attempt to weld tab terminals or any other object to the battery body. If welding is needed, please consult us.

The battery's gasket and separator use plastics with low softening temperatures. Also, an organic solvent with a low boiling point is used for the electrolyte.

If the battery is heated beyond a certain threshold, it may damage the gasket or separator, causing electrolyte leakage or performance degradation. In the worst case, explosion or combustion may result from excessive inner pressure.

For more information, please contact the sales division in charge.

Precautions for Proper Use of Coin Type Lithium Batteries

Be careful not to allow heat from the soldering iron or the hot air used for solder melting to damage the batteries during the removal of mounted electronic components.

Case Study and Explanation:

The following problem sometimes occurs: externally applied heat melts and deforms the gasket of a coin type lithium battery mounted on a printed circuit board. Due to deformation of the gasket, the battery gasket seal gradually weakens, and the electrolyte leaks out or evaporates through the gap between the gasket and the metal cap or between the gasket and the positive terminal case. As a result, the electrical characteristics of the battery degrade.

A plastic material with a low softening temperature is used for the gaskets and separators of the batteries. If a battery is heated to a high temperature the gasket or separator will sustain damage causing leakage or degradation of the battery characteristics.

[Overview of the problem]

It is occasionally necessary to remove (desolder) electronic components, including batteries that have already been soldered onto a printed circuit board.

Hot Air Tools are a commonly used method for melting solder joints to remove electronic components with multiple leads. However, the hot air may **heat the batteries** adjacent to the electronic components being removed.

In addition, when removing a mounted battery using a soldering iron and resoldering it, ensure that the heat applied by the soldering iron does not damage the battery.

<Problem examples>

Example 1: Electrolyte leakage at a user's site

Cause: When replacing or repairing electronic components with multiple leads, such as ICs and connectors, on a printed circuit board rejected from the production line, hot air of about 260°C was applied to melt the solder joints. During the application of hot air an adjacent battery was also exposed to the heat, its gasket melted and became deformed causing the battery's seal integrity to degrade gradually leading to electrolyte leakage.

Example 2: Memory erasure occurred at a user's site.

Cause: When a battery with terminals was mounted onto a printed circuit board, the soldering iron heated the battery to an extremely high temperature. The temperature of the battery itself abnormally increased and the battery gasket melted and became deformed. Afterwards, the electrolyte gradually evaporated from the battery due to the decreased integrity of the seal, degrading the battery's characteristics.

[Countermeasures]

- (1) When removing electronic components from a printed circuit board using hot air, be sure to remove any batteries first.
 - Regarding batteries with terminals, it is important to remove them quickly to prevent the soldering iron from transferring the extreme heat to the batteries.
 - If a battery is set in a holder, first remove the battery from the holder.
Remove the other electronic components only after following the above procedures.
- (2) When only using a soldering iron without hot air, remove the electronic components quickly so as not to allow excessive heat from the soldering iron to transfer to the batteries.

Note: Due to the potential safety hazard, never solder directly to the body of the battery. Solder to the terminals only.

Panasonic also offers heat-resistant BR type coin cells for use at high temperatures. Please contact us for more information.

Please thoroughly notify all relevant parties/departments of these precautions, including manufacturing and sales departments or subcontractors.

For more details, contact the Quality Assurance Group.