

Vertical Blanking Panels (Upper Panel Installation)

- Install Flap Seals on top edges of Upper Blanking Panels
- Install Left-side and Right-side Upper Blanking Panels to the backside of the front adjustable Equipment Rails.

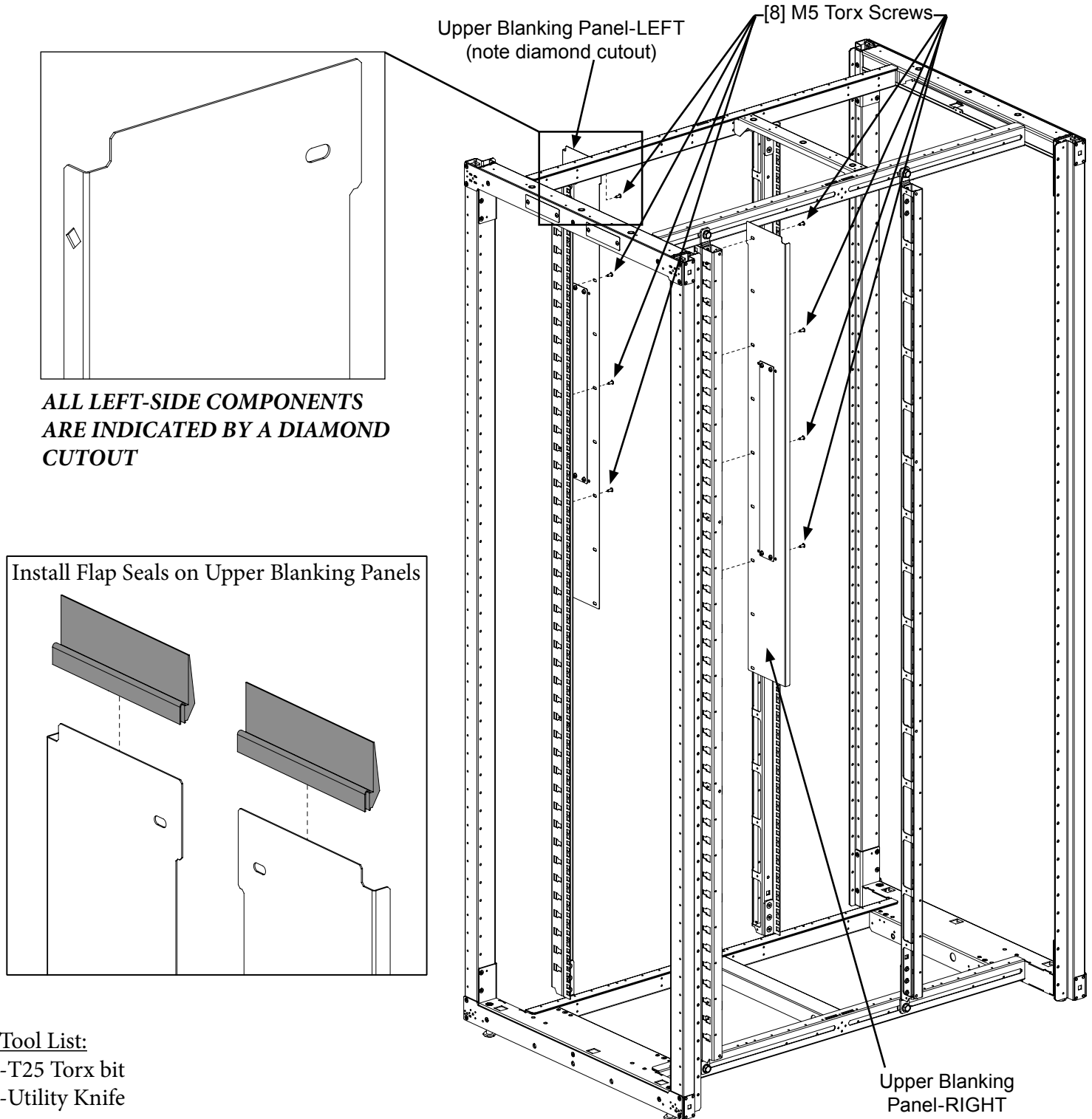

Vertical Blanking Panels (Lower Panel Installation)

- Install Left-side and Right-side Lower Blanking Panels
- Ensure that Lower Panels overlap Upper Panels

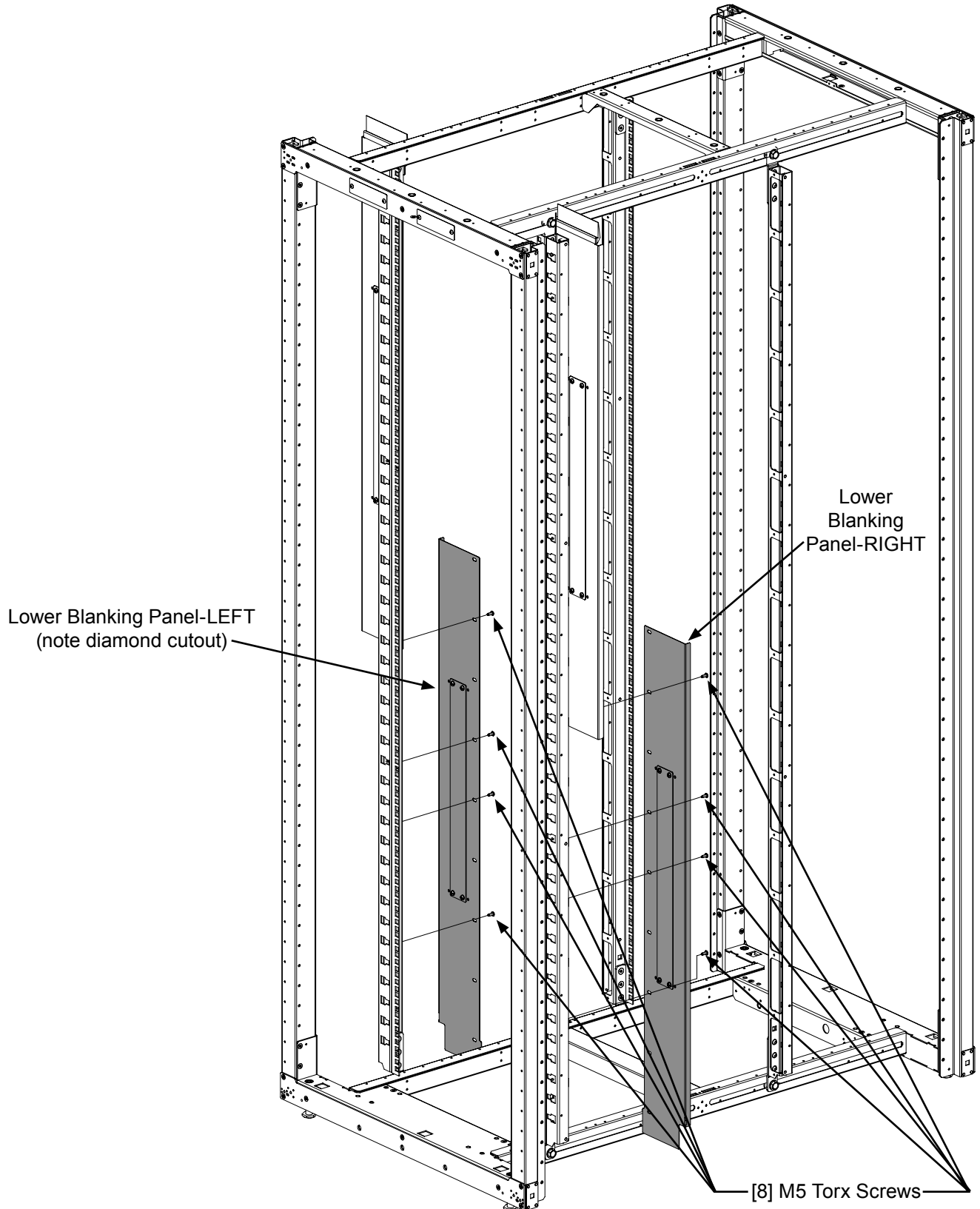

Horizontal Blanking Panels (Flap Seal and Screw Installation)

- Install [2] Flap Seal sections onto edges of Top and Bottom Horizontal Blanking Panels
- Insert [3] M5 Torx Screws into each Horizontal Blanking Panel

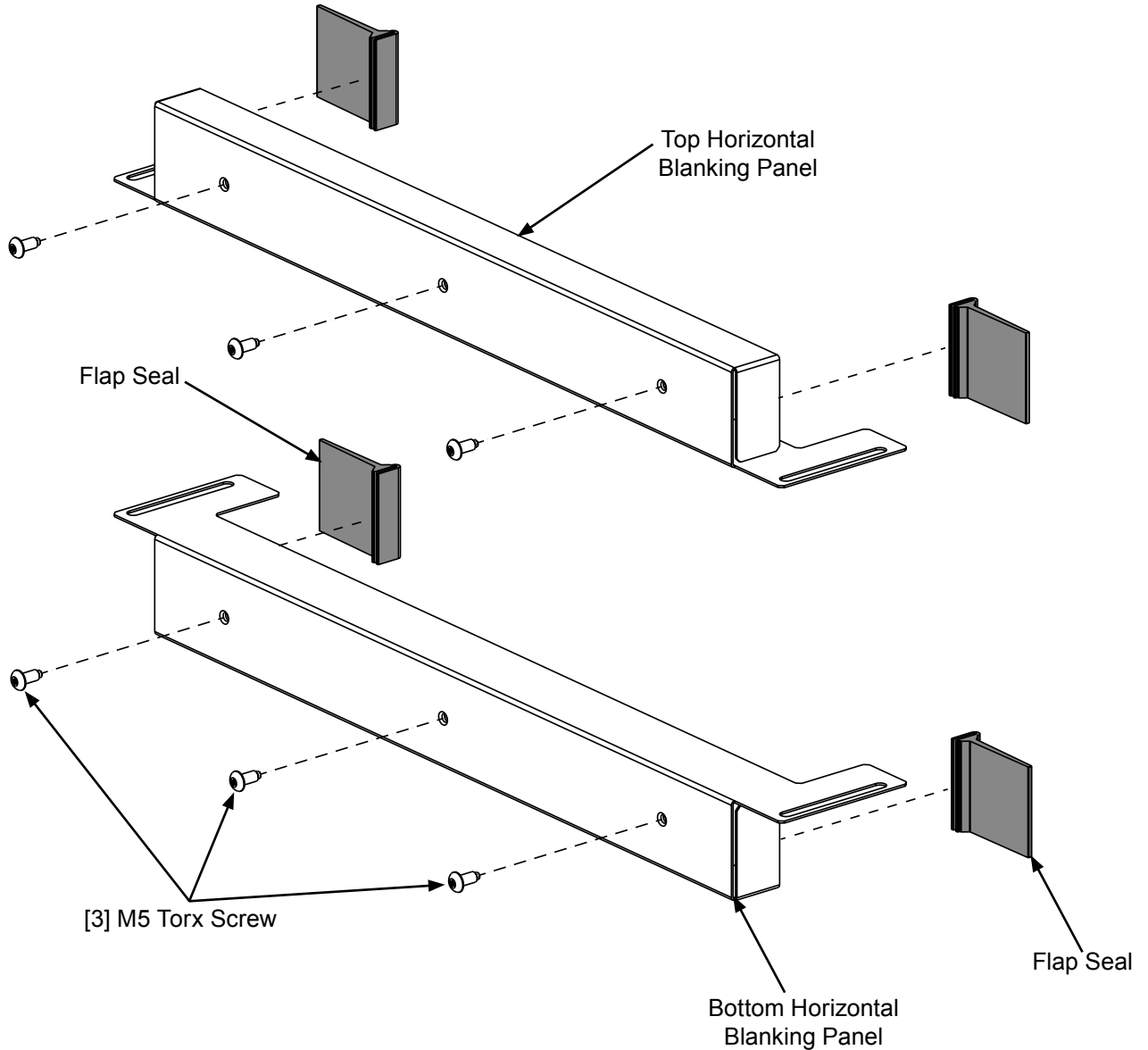

Vertical Blanking Panels (Top Seals)

- Align front face of Horizontal Blanking Panel with Equipment Rails and install to the top front to back beams using [2] M5 torx screws.
- Attach D-shaped Rubber Seal to Horizontal Blanking Panel
- Ensure that Flap Seals are positioned tight against top of cabinet.

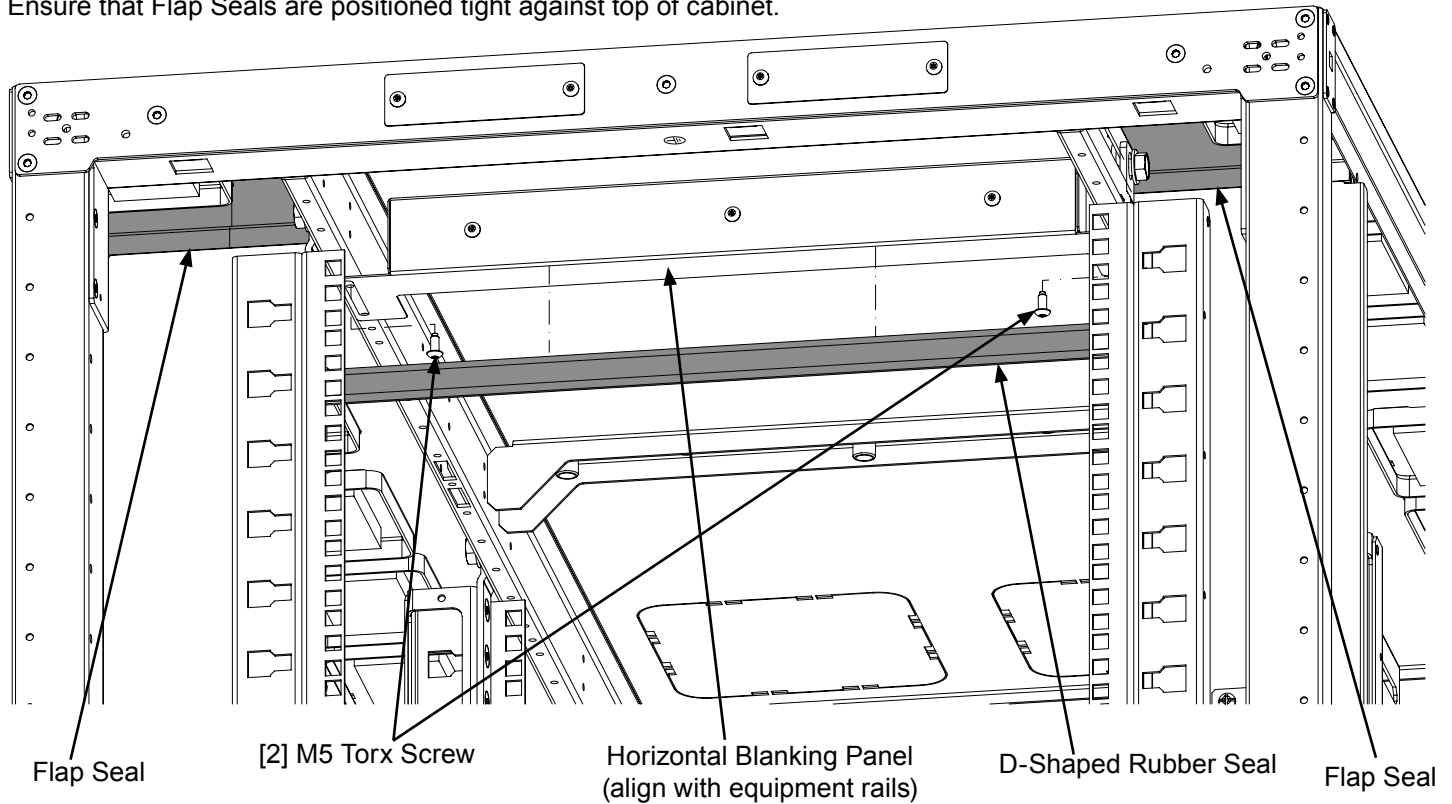

Top Blanking Panel (Integral Cabinet Top Cable Routing System - ONLY)

- Adjust width of Top Blanking Panel (if necessary use 8mm wrench to adjust nuts)
- Apply Adhesive Seal to top edge of Top Blanking Panel
- Loosen [3] screws on front face of Horizontal Blanking Panel
- Position keyholes of Top Blanking Panel over [3] screws, and slide panel down

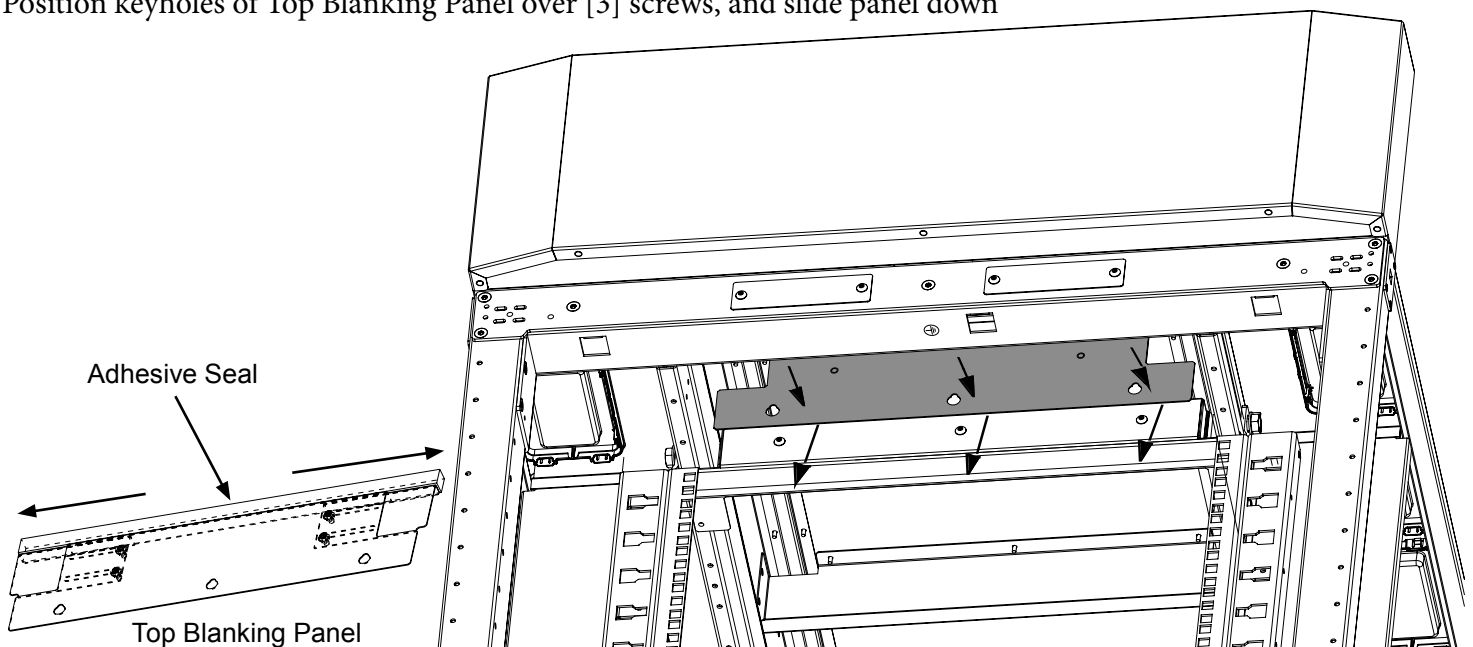

For Technical Support: www.panduit.com/resources/install_maintain.asp

Vertical Blanking Panels (Side Seals)

- Attach 3/8" Bulb Seals to vertical edges of Blanking Panels by sliding Seal channel over Blanking Panel flange. - Trim Seal length if necessary

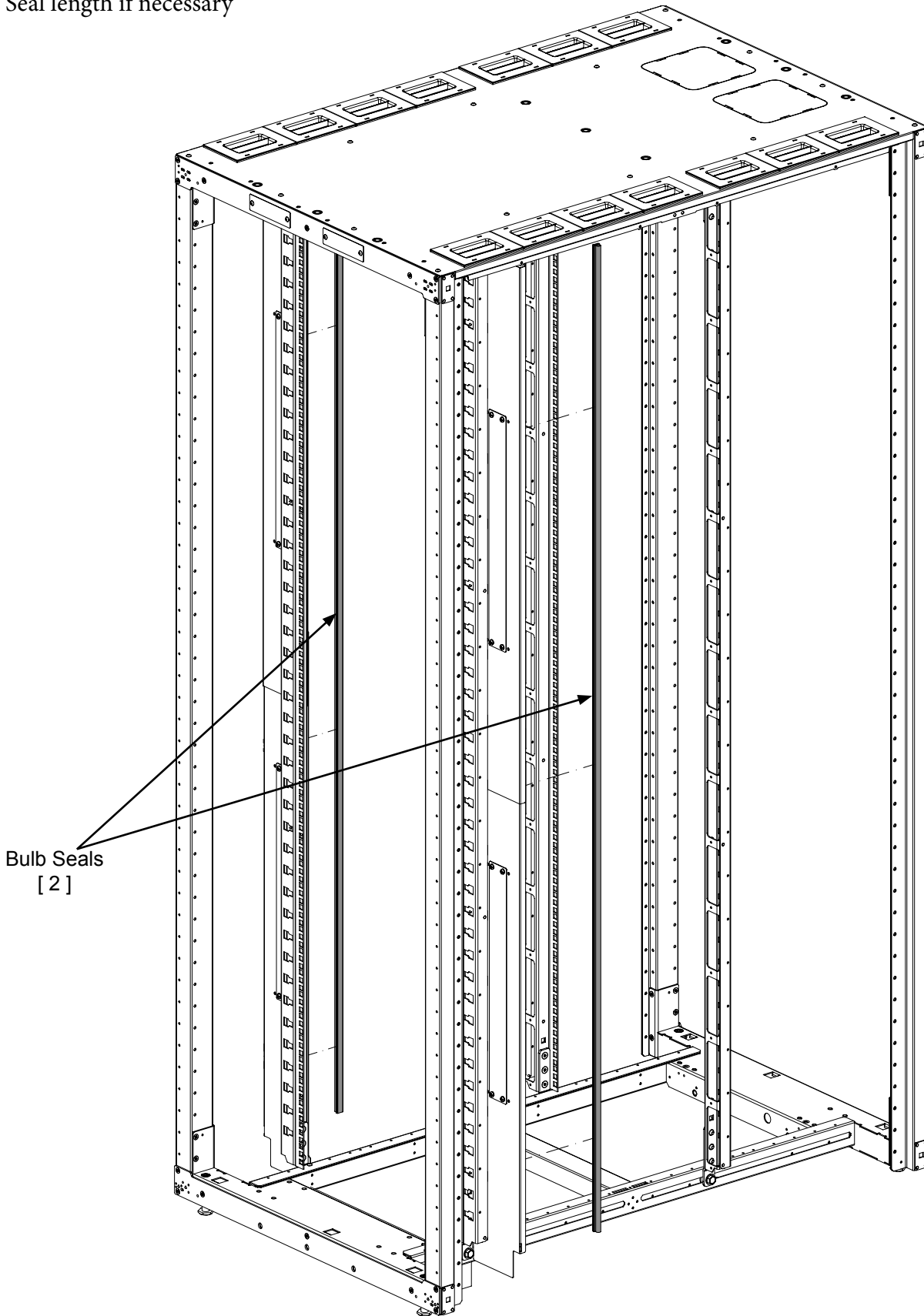

Bulb Seals
[2]

Vertical Blanking Panels (Floor Seals)

- Align front face of Horizontal Blanking Panel with Equipment Rails and install to the lower front to back beams using [2] M5 Torx screws.
- Install [2] Bottom Seal Brackets (Left Bracket is noted by diamond cutout) using [2] M5 Torx Screws
- Attach D-shaped Rubber Seal to Horizontal Blanking Panel.
- Attach 25mm x 50mm Foam Seals to bottoms of Horizontal Blanking Panel and [2] Bottom Seal Brackets
- Attach 13mm x 25mm Foam Seals to outer edge of [2] Bottom Seal Brackets.

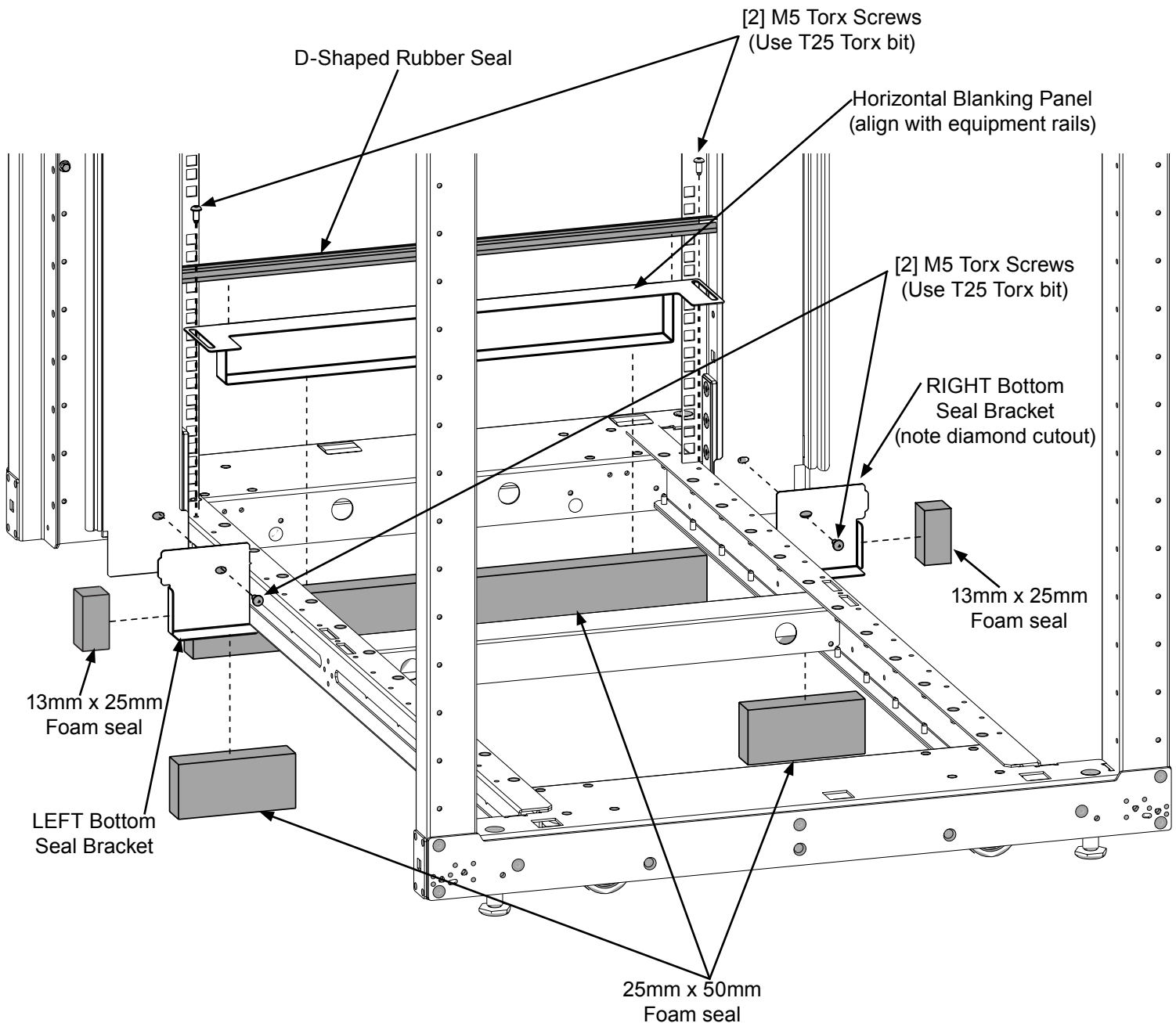

Cabinet to Cabinet Seal

- Align Between Cabinet Bracket so the front face overlaps the front face of the Blanking panels.
- While holding Between Cabinet Bracket, attach Seal Cover to the Between Cabinet Bracket using M5 Torx Screw.
- Attach 25mm x 50mm Foam Seal to the bottom of the Seal Cover.

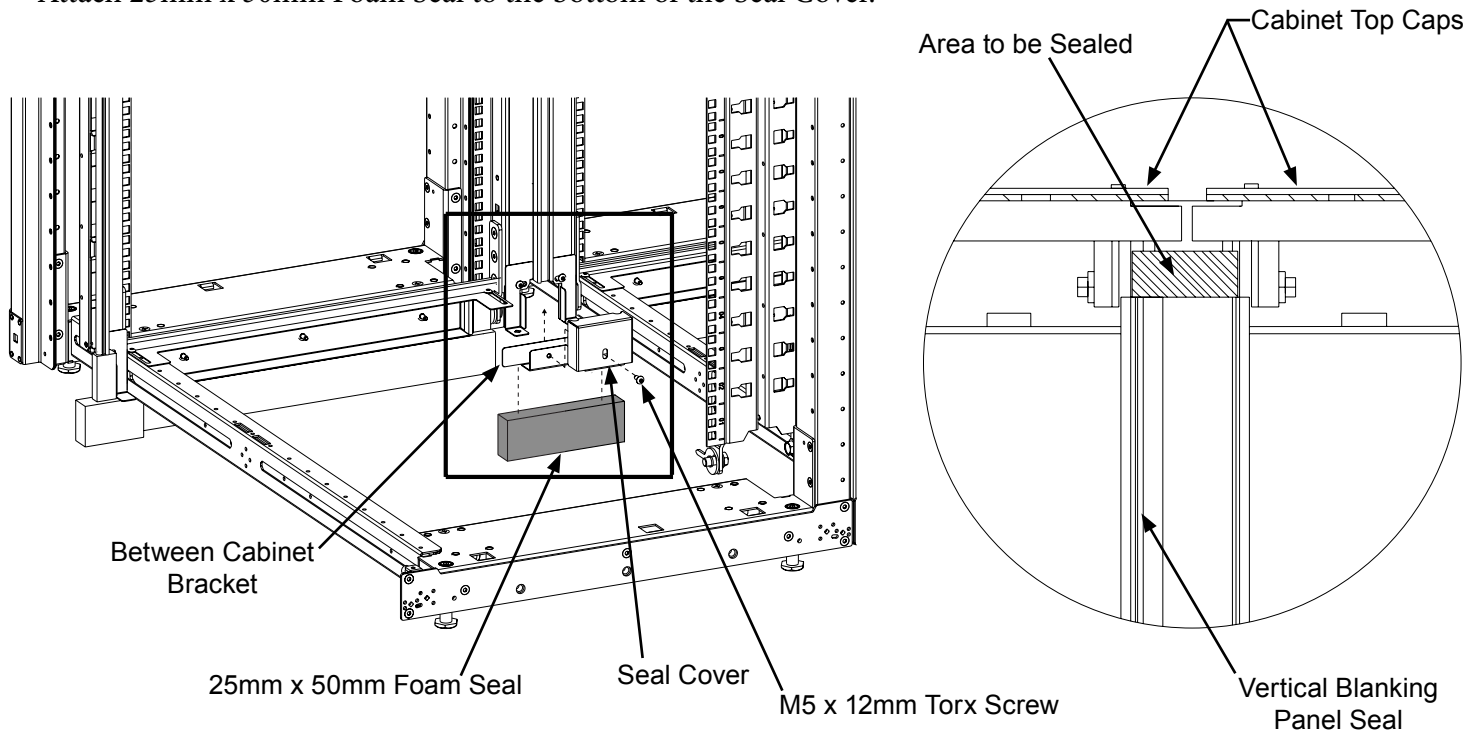

Top Cabinet to Cabinet Gap Sealing Installation

-Air Gap between top cap and Blanking Panels should be sealed with Blanking Foam Seal

Step 1

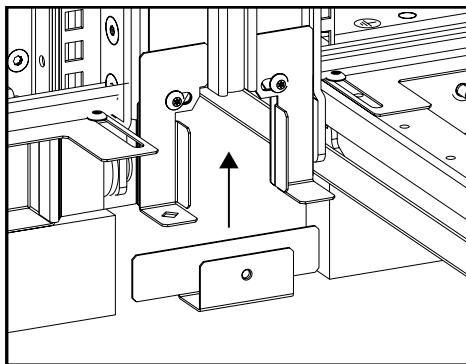

Step 2

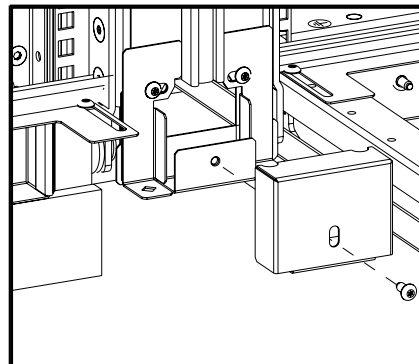

Step 3

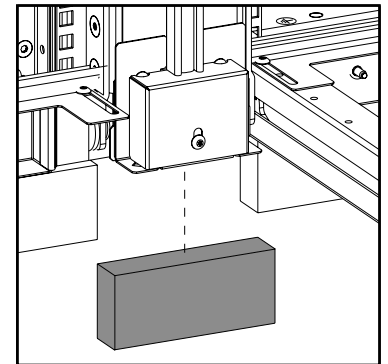

For Instructions in Local Languages and Technical Support:

www.panduit.com/resources/install_maintain.asp

PANDUIT

www.panduit.com

E-mail: techsupport@panduit.com

Phone: 866-405-6654