

Hardware Components

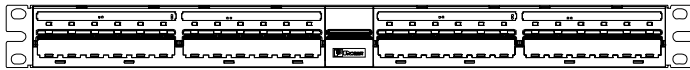

PANVIEW iQ Patch Panel

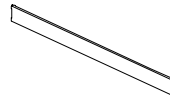

(4) ULTIMATE ID Label Covers

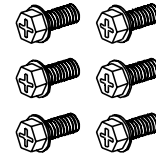

(6) #12-24 x 0.5" Grounded Bonding Screws*

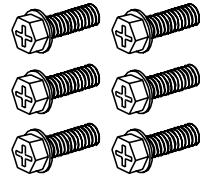

(6) M6 x 1.0 x 16 Grounded Bonding Screws*

* Only 4 screws are needed for installation.

Rack Mounting and Grounding

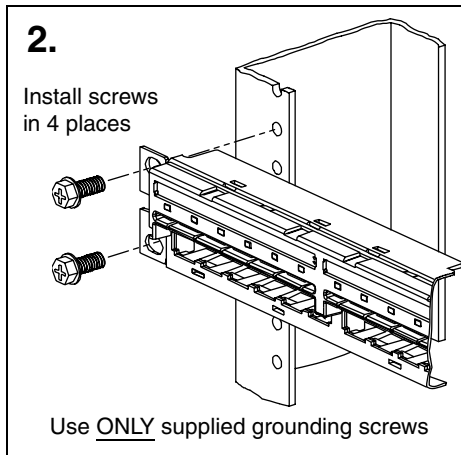
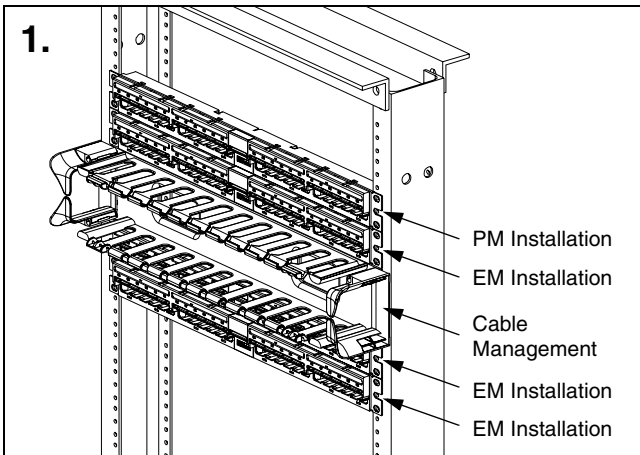

Warning If supplied screws do not fit or work with your rack or rack cabinet to provide appropriate grounding, the following screws are recommended:

- Thread Forming Screw, M5 x 12mm (Part # RGTM5-C)
- Thread Forming Screw, #10-32 x 1/2" (Part # RGTS1032-C)

While PViQ Patch Panels work interchangeably with either the Panel Manager (PM) or the Expansion Module (EM), it is recommended that PViQ Patch Panels be placed in a manner that will efficiently accommodate one (1) PM for every three (3) EMs, with appropriate cable management installed for proper cable routing. **NOTE:** PM can be arranged at either the top or bottom of order depending on need or preference.

Mount the PViQ Patch Panel onto the face of the rack or rack cabinet using four (4) of the supplied grounding screws as shown. Use either the #12-24 x 0.5" or M6 x 1.0 x 16 screws depending on the rack or cabinet.

PViQ Patch Panels **MUST** be properly grounded to ensure accurate system operation.

MINI-COM Module Installation

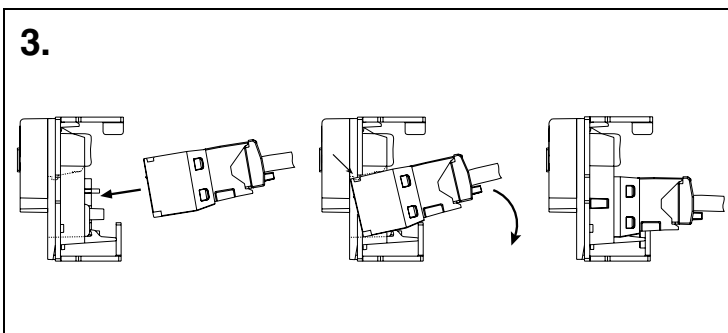

With the PViQ Patch Panel secured to the rack or cabinet, proceed to install terminated jack modules into the patch panel (as shown above). **NOTE:** The PViQ Patch Panel accepts all MINI-COM Copper Jack Modules and LC Fiber Adapters.

(Recommended) Cable Routing

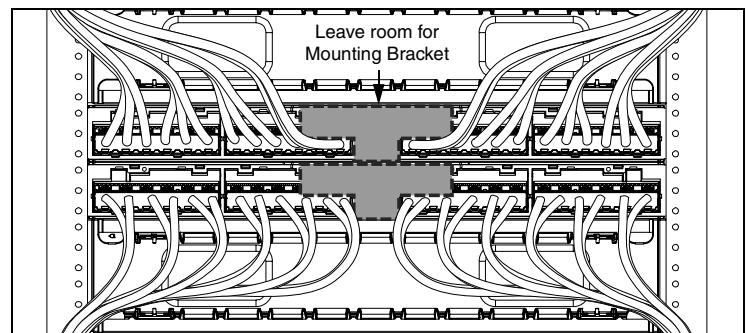

It is advisable to prepare cable management by routing cables into a left/right and upper/lower separation as you install the terminated jack modules (as shown above) to reserve appropriate space for the addition of mounting bracket later.

Label / Label Cover Installation

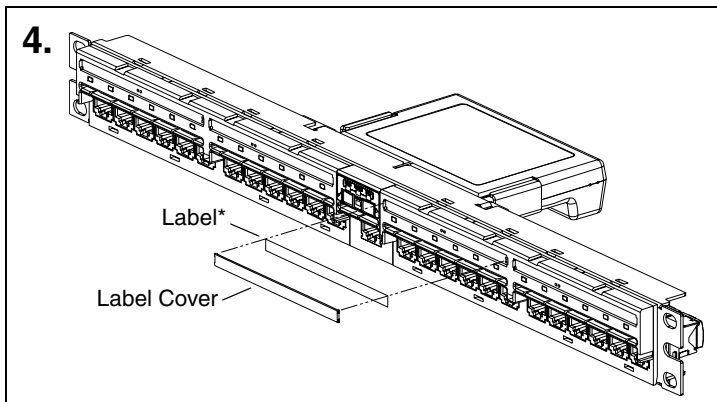

Suggested Label Solutions for TIA/EIA-606-A Compliance			
Patch Panel Part Number	Laser/Ink Jet Desktop Printer Label	PANTHER LS8E Hand-Held Printer Label	COUGAR LS9 Hand-Held Printer Label
All PViQ Patch Panels	UILJ6	UILS8BW	UILS8BW

To label PViQ Panel according to TIA/EIA-606-A standard, *ULTIMATE ID* labels (not included) should be created and installed (as shown). Label covers (included) should be installed to protect the label.

* Write on labels are not included with this patch panel per TIA-EIA-606-A standard which states: "To maximize legibility, all labels shall be printed or generated by a mechanical device, and shall not be written by hand." (Refer to table above for label products)

WARNINGS:

If a non-PANDUIT power source is used, it must:

- Provide over current protection appropriate to the size of the power wiring connected to the PViQ System.
- Provide an isolated (SELV) source per National requirements.
- Be certified for use with ITE equipment per National requirements.
- Provide a nominal 12VDC source to the PM (min. 11.4VDC and max 12.6VDC).
- Provide a 12VDC output which is electrically isolated from earth ground (minimum 1500 V isolation).
- Have an output power rating of minimum 30W, which is sufficient for powering PViQ System and associated loads.

PViQ European Emissions Warning:

Product is not intended for use in a residential environment. Use of this product in residential areas may cause electromagnetic interference.

Notes:

1. Never touch un-insulated communications wiring or terminals unless the communication line has been disconnected at the network interface.
2. Only trained and qualified service personnel should install or service PViQ Systems.
3. Before installing or servicing PViQ or communication wiring, be aware of the potential for electrostatic discharge (ESD).

ATTENTION:

Observe precautions for handling electrostatic sensitive electronic devices when installing this product. Ensure that you are properly grounded with a wrist strap or equivalent while installing PM or EM modules.

For Instructions in Local Languages and Technical Support:

www.panduit.com/resources/install_maintain.asp



www.panduit.com

E-mail: cs@panduit.com

Fax: (708) 444-6993