



BLUETOOTH® WIRELESS  
TECHNOLOGY DEVICES  
AS INDUSTRIAL SENSOR



## BLUETOOTH® WIRELESS TECHNOLOGY DEVICES AS INDUSTRIAL SENSOR

### **Blu2Light - The intelligent wireless lighting control solution**

Blu2Light is the first completely open Bluetooth® wireless technology system with mesh functionality for the professional lighting market, which, in addition to a variety of functions for lighting control, offers the luminaire manufacturer added IoT benefits with maximum system security.

### **Blu2Light Industrial Sensor**

The Blu2Light Industrial Sensor enables the use of our Blu2Light system in industrial applications. The product is powered directly by DALI. Installation is at high altitudes or in applications where a high level of IP protection is required.

### **Blu2Light Industrial Sensor**

- **ENABLES THE OPERATION OF THE BLU2LIGHT NETWORK IN INDUSTRIAL APPLICATIONS**
- **INTEGRATED BLUETOOTH® MESH RADIO MODULE**
- **INSTALLATION IN INDUSTRIAL HALLS OR APPLICATIONS WHERE HIGH IP PROTECTION IS REQUIRED.**
- **MAINTENANCE-FREE**
- **OPERATING LIFETIME: 50,000 HRS.**
- **PRODUCT GUARANTEE: 5 YEARS**



## Blu2Light Industrial Sensor

### Module with Bluetooth® wireless technology

For installation in industrial halls or

Applications where high IP protection is required

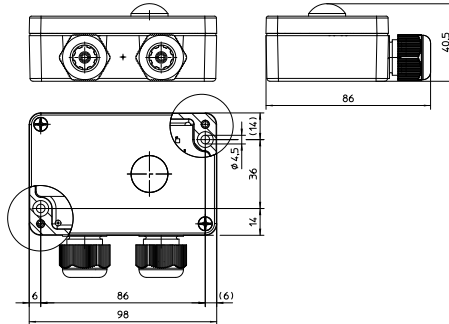

### ATTENTION:

- The module must be connected to the DALI supply by using terminals provided by the customer.

Type	Industrial Sensor
Ref. No.	187212
Communication	Blu2Light Mesh Network
Frequency range	2402–2480 MHz
HF output power	< 10 mW EIRP
Power consumption standby/operation	< 0.5 W
Power supply	via DALI bus
Ambient temperature $t_a$	0–50 °C
Humidity in operation:	5–95 %
IP protection	IP65
Protection class	II
Weight	1.35g
Output power	< 10 mW EIRP
Light sensor	0-1000 lx, V( ) compensated
Motion sensor	PIR detection range 0.1 to max. 12 m (depending on temperature)
Detection range (at $t_a = 20^\circ\text{C}$ )	At maximum mounting height of 12 m, this results in a detection range with a diameter of approx. 15 m

### Product guarantee

- 5 years
- The conditions for the Product Guarantee of the Vossloh-Schwabe Group shall apply as published on our homepage ([www.vossloh-schwabe.com](http://www.vossloh-schwabe.com)). We will be happy to send you these conditions upon request.



The values in this data sheet may change due to technical innovations and are subject to change without notice.

## Blu2Light Industrial Sensor

### General Safety and Mounting Instructions

- Only qualified persons are allowed to install Blu2Light products.
- Prior to installing and commissioning the system, read these instructions carefully. Only this will guarantee correct and safe handling. Please keep these instructions as you may need them later.
- The devices must always be disconnected before any work is carried out on them.
- The applicable safety and accident prevention regulations must be observed.
- Opening by unqualified personnel of the products is prohibited:  
Risk of death from electric shock!  
The devices must only be repaired by the manufacturer.

### Mounting

- Pay attention to the correct polarity according to the connection markings!

### Important note:

- Please refer to the installation instructions included with the product and the applicable Blu2Light system data sheet "How to Blu2Light" before installation. Make sure that the Bluetooth radio signal can propagate freely according to the specifications.
- All Blu2Light devices (ME, XS, XL, XXL, ...) that are supplied via DALI may only be connected to one DALI power supply! Therefore, it is not permissible to connect several Blu2Light devices to one power supply. In this case, malfunctions will occur.

### Setup and operation

- The Blu2Light devices are configured with the LiNA Connect app and can be operated via the LiNA Touch app.
- For the exact procedure for the configuration of the devices please refer to the instructions in the LiNA Connect app or in the corresponding documentation.
- A tablet is required for setup, both tablets and smartphones can be used for operation. Both are not included in the scope of delivery.
- For information on the iOS and Android operating systems that can currently be used, refer to the LiNA Connect/ LiNA Touch manual:



### Bluetooth® wireless technology

The Bluetooth® word mark and logos are registered trademarks owned by the Bluetooth SIG, Inc. and any use of such marks by Vossloh-Schwabe is under license. Other trademarks and trade names are those of their respective owners.



We, Vossloh-Schwabe Deutschland GmbH, herewith confirm that these devices comply with the basic requirements of the directive 2014/53 / EU and other relevant directives. The entire text of the declaration of conformity can be obtained from the following address: [www.vossloh-schwabe.com](http://www.vossloh-schwabe.com)

### EAC

Declaration of Conformity of the Eurasian Customs Union

### B2L

Symbol for marking Blu2Light capable products