

# XUSL4M

## Type 4 Safety Light Curtains with Integrated Muting Function User Manual

(Original Document)

05/2019

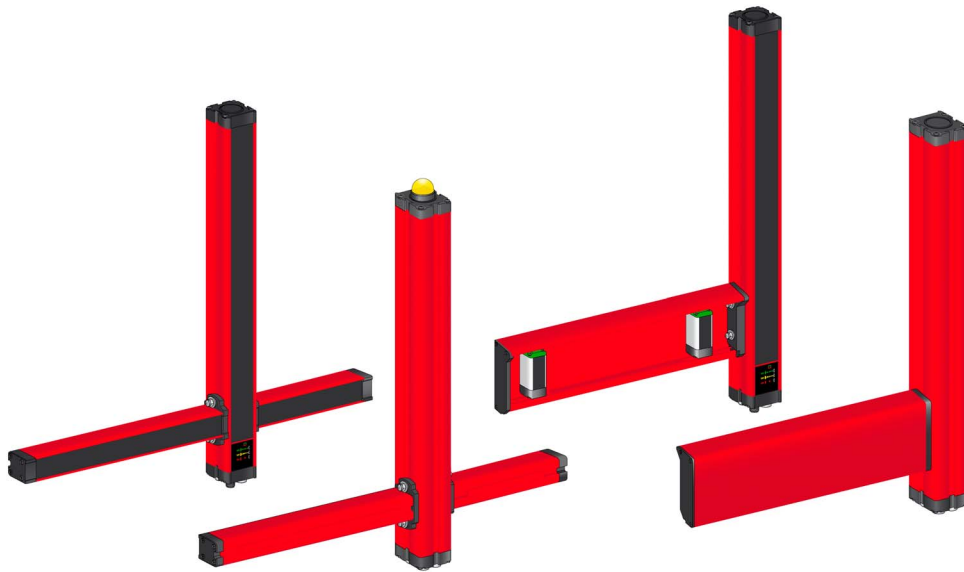

---

The information provided in this documentation contains general descriptions and/or technical characteristics of the performance of the products contained herein. This documentation is not intended as a substitute for and is not to be used for determining suitability or reliability of these products for specific user applications. It is the duty of any such user or integrator to perform the appropriate and complete risk analysis, evaluation and testing of the products with respect to the relevant specific application or use thereof. Neither Schneider Electric nor any of its affiliates or subsidiaries shall be responsible or liable for misuse of the information contained herein. If you have any suggestions for improvements or amendments or have found errors in this publication, please notify us.

You agree not to reproduce, other than for your own personal, noncommercial use, all or part of this document on any medium whatsoever without permission of Schneider Electric, given in writing. You also agree not to establish any hypertext links to this document or its content. Schneider Electric does not grant any right or license for the personal and noncommercial use of the document or its content, except for a non-exclusive license to consult it on an "as is" basis, at your own risk. All other rights are reserved.

All pertinent state, regional, and local safety regulations must be observed when installing and using this product. For reasons of safety and to help ensure compliance with documented system data, only the manufacturer should perform repairs to components.

When devices are used for applications with technical safety requirements, the relevant instructions must be followed.

Failure to use Schneider Electric software or approved software with our hardware products may result in injury, harm, or improper operating results.

Failure to observe this information can result in injury or equipment damage.

Schneider Electric Head Office  
35 Rue Joseph Monier  
CS 30323  
92506 Rueil-Malmaison, France  
© 2019 Schneider Electric. All rights reserved.

---

# Table of Contents

---



	<b>Safety Information</b> .....	5
	<b>About the Book</b> .....	7
<b>Part I</b>	<b>General</b> .....	9
<b>Chapter 1</b>	<b>Safety Requirements</b> .....	11
	Safety Requirements .....	11
<b>Chapter 2</b>	<b>Product Description</b> .....	13
2.1	General Information .....	14
	General Description .....	15
	How a Safety Light Curtain Works? .....	16
	Resolution .....	17
	Protected Height .....	18
	Response Time .....	19
	Safety Types .....	20
	Muting Function Description .....	21
	Risk Assessment .....	23
2.2	Safety Light Curtain Functions .....	25
	Operating Modes .....	26
	External Device Monitoring (EDM) or Machine Primary Control Element (MPCE) Monitoring .....	30
	Test Function .....	32
	Maximum Sensing Distance Selection .....	33
2.3	Muting Functions .....	34
	Muting Type Description .....	35
	Two Crossed or Parallel Muting Sensors, Unidirectional Mode (L2X/L2P), Timing Control .....	37
	Two Cross Muting Sensors, Bidirectional (T2X), Timing Control .....	41
	Four Parallel Muting Sensors, Bidirectional Mode (T4P) Timing (or “Concurrent”) Control and Sequential Control .....	45
	Muting Enable .....	48
	Partial Muting .....	50
	Muting Override .....	53
2.4	Operating States .....	56
	Operating States .....	56
2.5	System Components .....	59
	System Components Identification .....	59
<b>Part II</b>	<b>Preinstallation Considerations</b> .....	61
<b>Chapter 3</b>	<b>Safe Mounting Distance</b> .....	63
	European Safe Mounting Distance Formula .....	64
	Detection Zone Approaches .....	65
	U.S. Safe Distance Formula .....	69
<b>Chapter 4</b>	<b>Additional Mounting Considerations</b> .....	71
	Reflective Surface Interference .....	72
	Test Rod Procedure .....	74
	Additional Guarding .....	75
	Multiple Systems .....	76
<b>Part III</b>	<b>Installation, Wiring, and Startup</b> .....	79
<b>Chapter 5</b>	<b>Installation</b> .....	81
	Parts List .....	82
	Mounting the Safety Light Curtain .....	83
	Mounting the Safety Light Curtain with Single Beam Pre-Built Arms .....	85
	Mounting the Safety Light Curtain with Multibeam Pre-Built Arms .....	87
	Mounting the Safety Light Curtain with Individual Muting Sensors .....	90

<b>Chapter 6</b>	<b>Wiring</b> .....	<b>93</b>
	Overview .....	94
	XUSL4MA and XUSL4MB Transmitter Electrical Connections .....	95
	XUSL4MB Receiver Electrical Connections .....	97
	XUSL4MA Receiver Electrical Connections .....	99
	Connection Schematics .....	101
<b>Chapter 7</b>	<b>Start Up</b> .....	<b>105</b>
	Aligning the Transmitter and Receiver .....	105
<b>Part IV</b>	<b>Troubleshooting</b> .....	<b>107</b>
<b>Chapter 8</b>	<b>Receiver and Transmitter Troubleshooting</b> .....	<b>109</b>
	Transmitter Troubleshooting .....	110
	Receiver Troubleshooting .....	111
<b>Part V</b>	<b>Technical Characteristics</b> .....	<b>115</b>
<b>Chapter 9</b>	<b>Technical Characteristics</b> .....	<b>117</b>
	Safety Light Curtain Specifications .....	118
	Response Time and Safety Related Data .....	121
	Dimensions and Weights .....	124
	Muting Arms Dimensions .....	126
	Accessories .....	129
<b>Part VI</b>	<b>SoMute Software</b> .....	<b>137</b>
<b>Chapter 10</b>	<b>SoMute Presentation</b> .....	<b>139</b>
	General Information .....	140
	Software Installation .....	141
	Graphical Interface .....	142
	Toolbar .....	143
<b>Chapter 11</b>	<b>SoMute Features</b> .....	<b>145</b>
	Connection .....	146
	Viewing of Safety Light Curtain Configuration .....	147
	Programming (Configuration by Software) .....	148
	Configuration Check .....	149
	Report Configuration .....	150
	Errors Log .....	151
	Safety Light Curtain Activation .....	153
	Monitoring of the Safety Light Curtain Operation .....	154
<b>Chapter 12</b>	<b>SoMute Settings</b> .....	<b>155</b>
12.1	General Parameters .....	156
	Configuration .....	156
12.2	Muting Parameters .....	157
	Two Crossed or Parallel Muting Sensors, Unidirectional Mode (L2X/L2P), Timing Control .....	158
	Two Cross Muting Sensors, Bidirectional (T2X), Timing Control .....	160
	Four Parallel Muting Sensors, Bidirectional Mode (T4P) with Timing (or Concurrent) Control .....	161
	Four Parallel Muting Sensors, Bidirectional Mode (T4P) with Sequential Control .....	162
<b>Appendices</b>	.....	<b>163</b>
<b>Appendix A</b>	<b>Checkout and Test Procedures</b> .....	<b>165</b>
	Checkout Procedure .....	166
	Test Procedure .....	168
<b>Glossary</b>	.....	<b>171</b>



## Important Information

### NOTICE

Read these instructions carefully, and look at the equipment to become familiar with the device before trying to install, operate, service, or maintain it. The following special messages may appear throughout this documentation or on the equipment to warn of potential hazards or to call attention to information that clarifies or simplifies a procedure.



The addition of this symbol to a “Danger” or “Warning” safety label indicates that an electrical hazard exists which will result in personal injury if the instructions are not followed.



This is the safety alert symbol. It is used to alert you to potential personal injury hazards. Obey all safety messages that follow this symbol to avoid possible injury or death.

### **DANGER**

**DANGER** indicates a hazardous situation which, if not avoided, **will result in** death or serious injury.

### **WARNING**

**WARNING** indicates a hazardous situation which, if not avoided, **could result in** death or serious injury.

### **CAUTION**

**CAUTION** indicates a hazardous situation which, if not avoided, **could result in** minor or moderate injury.

### **NOTICE**

**NOTICE** is used to address practices not related to physical injury.

### PLEASE NOTE

Electrical equipment should be installed, operated, serviced, and maintained only by qualified personnel. No responsibility is assumed by Schneider Electric for any consequences arising out of the use of this material.

A qualified person is one who has skills and knowledge related to the construction and operation of electrical equipment and its installation, and has received safety training to recognize and avoid the hazards involved.

---

# About the Book



## At a Glance

### Document Scope

This manual describes the features, installation, wiring, usage, and troubleshooting of the XUSL4M (Type 4) safety light curtains with integrated muting function.

### Validity Note

The technical characteristics of the device(s) described in this manual also appear online.

To access this information online:

Step	Action
1	Go to <a href="http://www.tesensors.com">www.tesensors.com</a> .
2	In the <b>Search</b> box, type the model number of a product or the name of a product range. Do not include blank spaces in the model number/product range.
3	If more than one model number appears in the Products search results, click on the model number that interests you.
4	To save or print a data sheet as a .pdf file, click <b>Download product datasheet</b> .

The characteristics that are presented in the present document should be the same as those characteristics that appear online. In line with our policy of constant improvement, we may revise content over time to improve clarity and accuracy. If you see a difference between the document and online information, use the online information as your reference.

### QR Code

A QR code including the Telemecanique Sensors web address is present on the safety light curtain label. Technical documents are available in various languages in this website.



### Related Documents

Title of Documentation	Reference Number
Quick Start Guide	PHA67075 - 00

You can download these technical publications and other technical information from our website at [www.tesensors.com](http://www.tesensors.com)

### User Comments

We welcome your comments about this document. You can reach us by e-mail at [customer-support@tesensors.com](mailto:customer-support@tesensors.com).





---

# Part I

## General

---

### Overview

This part provides detailed information about the safety requirements and product description.

### What Is in This Part?

This part contains the following chapters:

Chapter	Chapter Name	Page
1	Safety Requirements	11
2	Product Description	13



---

# Chapter 1

## Safety Requirements

---

### Safety Requirements

#### Precautions

 <b>WARNING</b>
<b>IMPROPER SETUP OR INSTALLATION</b> <ul style="list-style-type: none"><li>• This equipment must only be installed and serviced by qualified personnel.</li><li>• Read, understand, and follow the compliance below before installing the XUSL4M safety light curtains with integrated muting function.</li></ul> <b>Failure to follow these instructions can result in death, serious injury, or equipment damage.</b>

#### Meeting Full Compliance

The compliance of a machine and the XUSL4M safety light curtains system with safety regulations, depends on the proper application, installation, maintenance, and operation of the XUSL4M safety light curtains system. These are responsibilities of the purchaser, installer, and employer.

The employer is responsible for selecting and training the personnel necessary to install, operate, and maintain properly the machine and its safeguarding systems. The XUSL4M system must only be installed, checked, and maintained by a qualified person. A qualified person is defined as “a person or persons who, by possession of a recognized degree or certificate of professional training, or who, by extensive knowledge, training, and experience, has successfully demonstrated the ability to solve problems relating to the subject matter and work” (ANSI B30.2).

To use the XUSL4M safety light curtains system, the given requirements must be met:

- The guarded machine must be able to stop anywhere in its cycle. Do not use a safety light curtain on a press with a full-revolution clutch.
- The guarded machine must not present a hazard from flying parts.
- The guarded machine must have a consistent stopping time and adequate control mechanisms.
- Heavy smoke, particulate matter, and corrosives may affect the efficiency of a safety light curtain. Electro-sensitive protective equipment is not suitable for outdoor<sup>(1)</sup>, explosive atmospheres, and underwater applications. Do not use XUSL4M safety light curtains in this type of environment.  
**(1):** Electro-sensitive protective equipments are not suitable for outdoor use without additional suitable protection.
- All applicable governmental and local rules, codes, and regulations must be satisfied. This is the user and employer responsibility.
- All safety-related machine control elements must be designed so that an alarm in the control logic or the control circuit breakdown does not lead to a XUSL4M safety light curtains system failure.
- The proper functioning of the XUSL4M safety light curtains and its operating line must be checked on a regular basis based on the level of safety required by the application. For example, number of operations, level of environmental pollution, and so on.
- Perform the Test Procedure (*see page 168*) during installation and after maintenance or adjustment. As well as in case of any modification of the machine controls, tooling, dies, machine or of the safety light curtain system.
- Perform only the test and diagnostic procedures outlined in this manual.
- Follow all procedures in this manual for proper operation of the XUSL4M safety light curtains system.
- All safety-related machine control circuit elements, including pneumatic, electric, or hydraulic controls must be control-reliable.
- Electro-sensitive protective equipment (ESPE) must not be used as a lock-out device.
- Additional measures may be necessary to ensure that the ESPE does not fail to danger when other forms of light radiation are present in a particular application. For example, use of cableless control devices on cranes, radiation from weld spatter, or effects from stroboscopic lights.

Use of the muting function requires special precautions by the safety system machine controller, installer, operator, and employer. The following information is only a partial list of requirements for muting applications and is not intended to be a complete guide to muting standards. The employer must contact the local safety authority for specific requirements regarding the machine, machine controller, and safety-related control system.

Schneider Electric provides the following information for reference only, and makes no claim regarding its accuracy, completeness, or effectiveness for a specific application:

- Mute the safety light curtain only during the non-hazardous portion of the machine cycle.
- If the machine tool has reversing capability that could cause a muting hazard, provide a control wiring diagram that includes an automatic method of preventing muting in the reverse direction.
- Depending on the risk assessment, provide one or more visual indicators that illuminate when the safety light curtain is in a muted condition.
- When used, ensure that the mute indicators are visible from any normal machine operator position and from the position from which any muting adjustments are normally carried out.
- Ensure that the safety light curtain cannot enter a mute condition when a fault is present.
- Provide two, independent muting signal sources to the XUSL4M. A single, simple cam-operated limit switch is inadequate as a muting signal source since its failure can remain undetected.
- Ensure that additional guarding is used to limit access to any hazardous zone not covered by the safety-related device system.
- The muting position (of the mute signal source) shall be secured against unauthorized adjustment by provision of special tools, key entry, electronic passwords, and the positioning and mounting of associated limit switches.
- Additional guarding may be required to limit access to hazardous zones not covered by the safety device system.

The enforcement of these requirements is beyond the control of Schneider Electric. The employer has the sole responsibility to follow the preceding requirements and any other procedures, conditions, and requirements specific to the machinery.

### Product Support

For more information about products and services in your country, visit [www.tesensors.com](http://www.tesensors.com).

---

# Chapter 2

## Product Description

---

### Overview

This chapter describes the general information, safety light curtain functions, muting functions, timing and sequence diagrams, operating states and system components.

### What Is in This Chapter?

This chapter contains the following sections:

Section	Topic	Page
2.1	General Information	<a href="#">14</a>
2.2	Safety Light Curtain Functions	<a href="#">25</a>
2.3	Muting Functions	<a href="#">34</a>
2.4	Operating States	<a href="#">56</a>
2.5	System Components	<a href="#">59</a>

## Section 2.1

### General Information

---

#### Overview

This section describes general information of the safety light curtain.

#### What Is in This Section?

This section contains the following topics:

Topic	Page
General Description	<a href="#">15</a>
How a Safety Light Curtain Works?	<a href="#">16</a>
Resolution	<a href="#">17</a>
Protected Height	<a href="#">18</a>
Response Time	<a href="#">19</a>
Safety Types	<a href="#">20</a>
Muting Function Description	<a href="#">21</a>
Risk Assessment	<a href="#">23</a>

## General Description

### Overview

The XUSL4M safety light curtain system is used where personnel protection is required. The basic applications include hand and body detection around hazardous equipment such as:

- Palletizers
- Roll handling equipment
- Automated equipment
- Packaging machines
- Robotic work cells
- Transfer lines
- Assembly lines

### Product Description

The XUSL4M safety light curtain is an optoelectronic multibeam safety system belonging to the category of Type 4 electro-sensitive devices (in accordance with EN 61496-1,2). It is equipped with the Muting function for the protection of persons exposed to hazardous machines.

XUSL4M safety light curtains permit integration of the Muting sensors that are connected directly to the connectors on the safety light curtain.

The Muting logic and the operating parameters in the hardware configuration Basic models (XUSL4MB) are fully defined by the connections of the main connector.

Software Programmable Advanced models (XUSL4MA) retain the features of non-software programmable models (XUSL4MB) and allow the configuration of various parameters and additional features via the SoMute software.

The main features of XUSL4M safety light curtain are:

- Resolution: 30 mm (1.18 in.) and 40 mm (1.57 in.) – 2, 3, and 4 beams.
- Integration of the main safety functions, including self-monitoring of static outputs, EDM, and Start/Restart Interlock.
- Outline dimensions: 55 x 50 mm (2.17 x 2 in.).
- Protected height: 300...2200 mm (11.81...86.61 in.).
- Degree of protection: IP65 / IP67.
- Operating temperature (no condensation): -30...+55 °C (-22...+131 °F).
- Integrated safety light curtain status indication.
- Integrated muting lamp and partial muting on XUSL4MA models.

## How a Safety Light Curtain Works?

### General Description

A safety light curtain system is an optical infrared beam guarding system that is used to protect operators close to hazardous zones. It stops the movement of parts in this zone when at least one of the light beams is interrupted. This system consists of a microprocessor-controlled receiver and transmitter facing each other and that are not physically interconnected. An array of infrared LEDs is located in the transmitter that emits infrared beams to photo-sensitive cell array located in the receiver. The infrared LEDs are triggered one after the other and the receiver photo-cells are synchronized to detect only the corresponding beam.

When the detection zone is not interrupted, the two redundant safety outputs are active (ON state) and enables the equipment that is connected downstream to work properly. When an object of a size greater or equal to the resolution interrupts at least one beam, the two redundant safety outputs switch OFF (OFF state) in order to stop the machine.

This figure describes the safety light curtain:

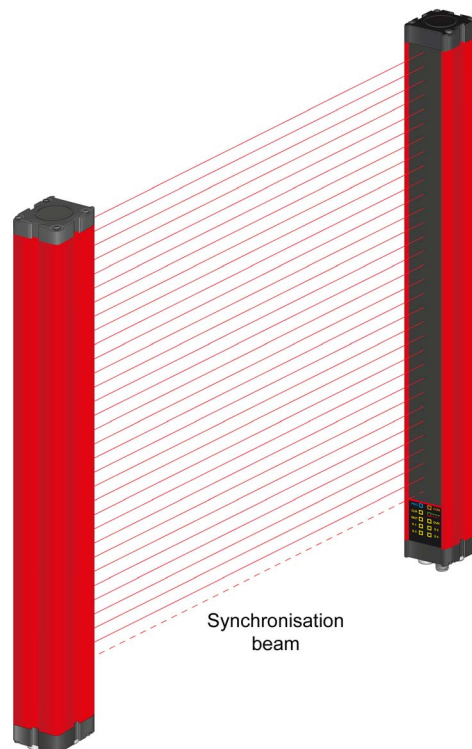



## Resolution

### General Description

Resolution (**R**) is also called Minimum Object Sensitivity (**MOS**) or Detection Capability. This is the smallest diameter (object) that a safety light curtain system is capable of detecting with absolute certainty.

This figure describes the resolution of the safety light curtain system:

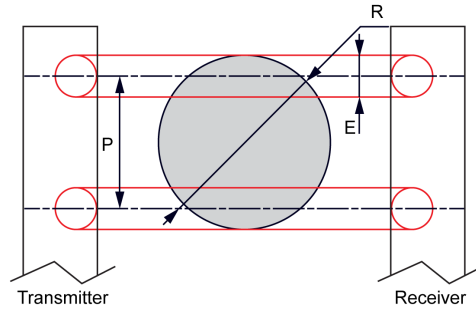

$$R = P + E$$

Where:

**P** = distance between the axis of two adjacent beams.

**E** = diameter of the beams.

Detection	Resolution	P	E
Hand	30 mm (1.18 in)	20 mm (0.78 in)	9 mm (0.35 in)
	40 mm (1.57 in)	30 mm (1.18 in)	9 mm (0.35 in)
Body	2-3-4 beams	500-400-300 mm	9 mm (0.35 in)

**NOTE:** The beam diameter values are approximative because they can vary depending on several factors (for example, the distance between transmitter and receiver).

## Protected Height

### General Description

The protected height ( $H_p$ ) is the zone (or height), for which an object (whose diameter is at least equal to the resolution  $R$ ) is detected with absolute certainty.

This figure describes the protected height for the safety light curtain:

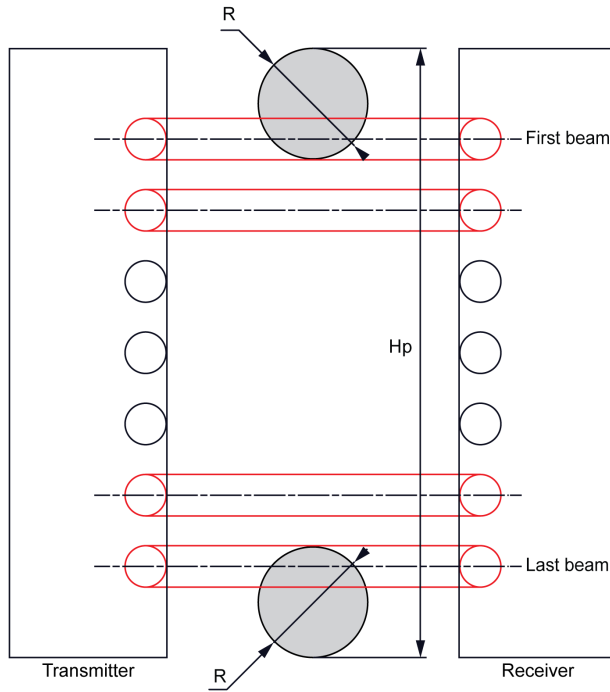

## Response Time

### General Description

European standard EN/ISO 13855 incorporates the various aspects of response time in the formula for calculating the Safe Mounting Distance ([see page 63](#)).

The total response time (**T**) corresponding to the overall system stopping performance is calculated by the given formula:

$$\mathbf{T = t1 + t2}$$

Where:

**t1** = Response time of the protection device (in second). This is the time indicated for the XUSL4M ranges. It is the total time between detection by the device and switching of the output component. Refer to the Response Time and Safety Related Data ([see page 121](#)).

**t2** = Stopping time of the machine (in second): maximum time required to terminate the hazardous machine function after the output signal from the safeguard achieves the OFF-state. This information is supplied by the machine manufacturer. The response time of the control system of the machine is included in **t2**.

## Safety Types

### General Description

XUSL4M safety light curtains are Type 4 compliant. No Type 2 models available for integrated muting models.

### XUSL4M (Type 4)

The type 4 design is based on redundant automatic cross-checking architecture. This architecture enables immediate failure detection within the response time. The type 4 safety light curtains are suitable for applications where the risk analysis demonstrates a moderate or severe injury risk to operators. The type 4 safety light curtain systems are available for hand and body detection.

The XUSL4M safety light curtains are compliant with type 4 (EN/IEC 61496-1), SIL 3 (EN/IEC 61508) - SILCL3 (EN/IEC 62061), and PLe - Cat. 4 (EN/ISO 13849-1).

This figure describes the operating fault detected for the type 4 safety light curtain:

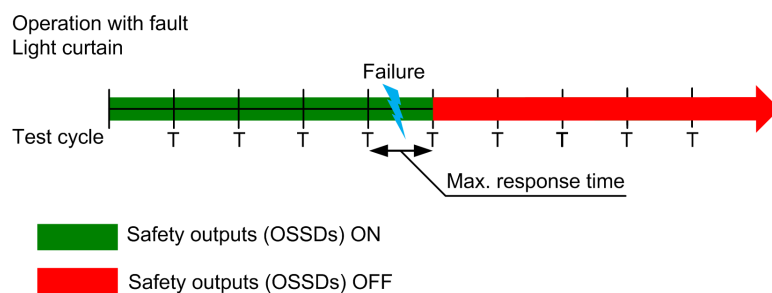

## Muting Function Description

### Muting

Muting bypasses the protective function on safety-related control systems during a predetermined, non-hazardous portion of the machine operation.

The muting mode is active only when the correct sequence of muting sensor input signals (two or more) is achieved. The object of the correct muting sensor selection and orientation is to recognize the presence of the work piece material always as the intended means to start or stop the muting sequence.

The main application is to allow material transit and prevent access to the people.

Example: Pallet exit from the hazardous zone

The safety light curtain is equipped with Muting sensors able to discriminate between the person and the material allowed to get through the controlled safety light curtain.

The essential requirements concerning the Muting function are described in the following Standards:

- IEC TS 62046 - "Application of protection devices for people detection".
- EN 415-4 - "Safety on packaging machines – Palletizers and Unpalletizers".
- IEC 61496-1 - "Electro-sensitive protective devices".

When the system is in the muting state, an indicator lamp may be lit. If so, this lamp must be visible to all personnel in the immediate area.

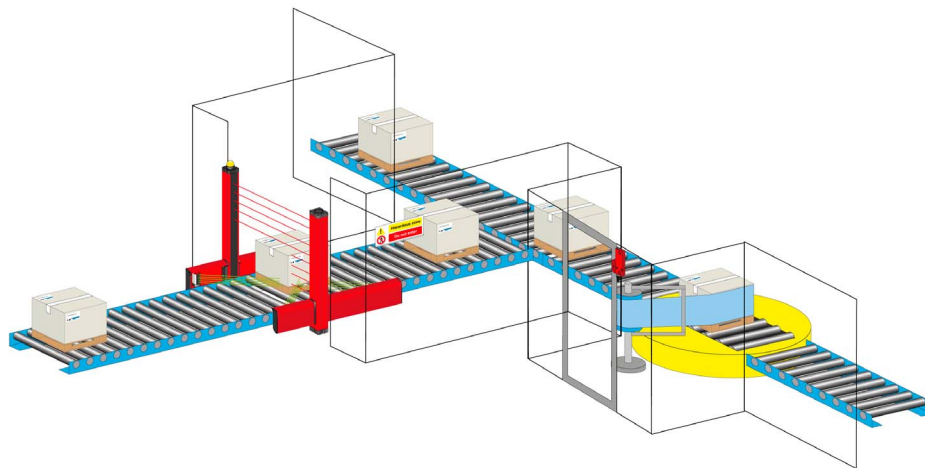

### **⚠ WARNING**

#### **IMPROPER MUTING UTILIZATION**

Muting state is a temporary bypass or disabling of the safety light curtain detection zone. It is the duty of any user or integrator to check whether the use of muting function is consistent with the application risk assessment.

**Failure to follow these instructions can result in death, serious injury, or equipment damage.**

### **⚠ WARNING**

#### **IMPROPER MUTE INDICATION**

Before using an indicator (for example a lamp) to warn that the muting function is active, it must be considered whether the implementation of this mute indicator could lead to make improper attempts to access the hazardous zone while the muting function is active.

**Failure to follow these instructions can result in death, serious injury, or equipment damage.**

### **⚠ WARNING**

#### **UNEXPECTED OUTPUT OPERATION**

Sensors position and sequence activation determine the muting function.

Verify that muting is functioning before commissioning the safety light curtain.

**Failure to follow these instructions can result in death, serious injury, or equipment damage.**

### Muting Principle

The following figures present the principle of a muting sequence with two pairs of thru-beam photocells. In this example, the transported material moves in the direction of the hazardous zone:

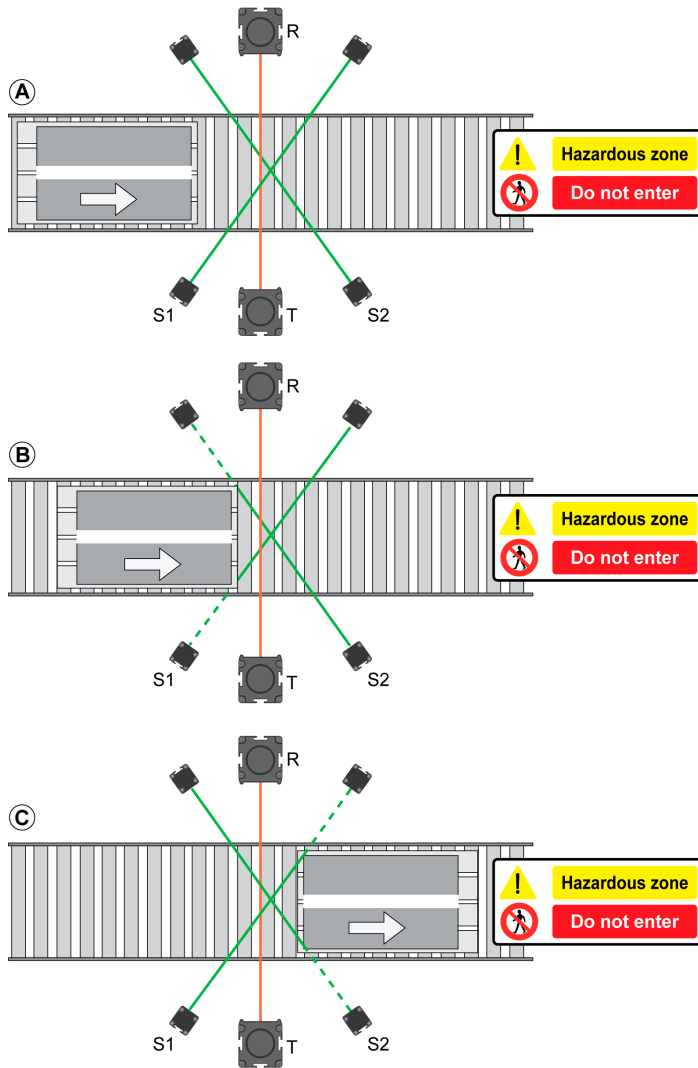

- A** The object is not detected by the muting sensors.
- B** The object is detected by the muting sensors. When the two beams are interrupted in compliance with the expected muting sequence, the muting function is activated. The object crosses the safety light curtain beam without stopping the machine.
- C** When at least one beam is cleared, the muting function is stopped.

## Risk Assessment

### General Description

Risk assessment and risk reduction are **iterative process** described in EN/ISO 12100, EN/IEC 61496-1, EN/IEC 61508 & EN/IEC 62061 (SIL), and EN/ISO 13849-1 (PL). There are various techniques for risk assessment, and not one of it can be considered as the right way to perform risk assessment. The standard specifies some general principles but does not specify exactly what has to be done in each case.

For safety-related data, refer to Response Time and Safety Related Data ([see page 121](#)).

This flowchart describes the risk assessment process:

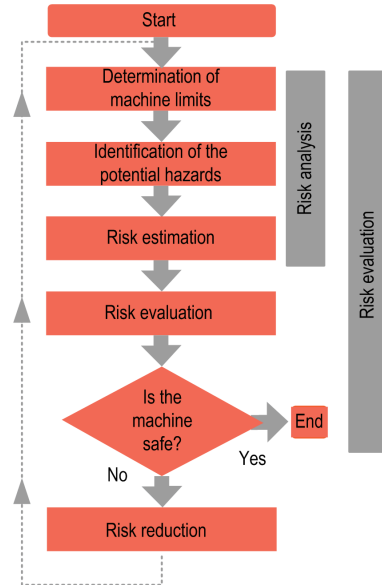

Essential steps for risk assessment are the following:

- Define tolerable risk level.
- Identify hazards.
- Analyze hazards.
- Determine whether the risks are below an acceptable level.
- Define protection measures if risks are above a tolerable level.
- Check whether protection measures taken lead to an effective risk reduction (Iterative process).

This figure describes the elements of risk to take into account for the risk estimation:

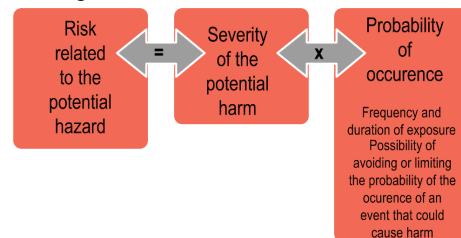

For more information, refer to:

<https://www.schneider-electric.com/ww/en/download/document/DIA4ED1100102EN>.

## Reference Standards

The following table describes the main reference standards:

Standard	Risk assessment	Description
EN/ISO 12100	Risk assessment and risk reduction	Safety of machinery. General principles for design. Risk assessment and risk reduction.

Standard	Safety level	Description
EN/ISO 13849-1	Performance level (PL)	Safety-related part of control system.
	Category (Cat)	General principles for design.
EN/IEC 61508	Safety integrity level (SIL)	Functional safety of electrical/electronic/programmable electronic safety-related systems.
EN/IEC 62061	Safety integrity level claim limit (SILCL)	Safety of machinery. Functional safety of safety-related electrical, electronic, and programmable electronic control systems.
EN/IEC 61496-1 EN/IEC 61496-2	Type	Electro-sensitive protective equipment. General requirements and tests. Particular requirements for equipment using active opto-electronic protective devices (AOPDs).

**NOTE:** For more muting operation details, refer to IEC TS 62046 (Safety of machinery – Application of protective equipment to detect the presence of persons).



---

## Section 2.2

### Safety Light Curtain Functions

---

#### Overview

This section describes the various functions of the safety light curtain.

#### What Is in This Section?

This section contains the following topics:

Topic	Page
Operating Modes	<a href="#">26</a>
External Device Monitoring (EDM) or Machine Primary Control Element (MPCE) Monitoring	<a href="#">30</a>
Test Function	<a href="#">32</a>
Maximum Sensing Distance Selection	<a href="#">33</a>

## Operating Modes

### Introduction

The operating mode determines the start-up and operating behavior of the XUSL4M safety light curtain system. The operating mode descriptions in this section are derived from the operating state (*see page 56*).

### Automatic Start

In this mode, the system enters the Run state during startup without operator intervention, as long as the detection zone is not blocked. When the XUSL4M safety light curtain system is powered up, its safety outputs are OFF. If the detection zone is not obstructed and no faults are detected, it enters the Run state (*see page 56*) after 10 seconds maximum and the two safety outputs switch to ON state. In this state, when the XUSL4M safety light curtain system senses an object entering the detection zone, the machine changes from Run state to Stop state (*see page 56*) (the two safety outputs switch to OFF state). It remains in the Stop state until the obstruction is removed. The XUSL4M safety light curtain system automatically changes from Stop state to Run state when the detection zone is cleared without any fault detected.

### XUSL4MB Automatic Start

When OverRide1/RST (pin 10 of the main M12 12 pins connector) is not connected, the safety light curtain is configured in Automatic start/restart mode.



## ! WARNING

### IMPROPER AUTOMATIC START UTILIZATION

The manual Start/Restart is required in most Safety applications. If you use the automatic start function, check that this automatic start mode is compatible with risk assessment performed for the application.

**Failure to follow these instructions can result in death, serious injury, or equipment damage.**

### Manual Start/Restart

When the XUSL4M safety light curtain system is powered up, its safety outputs are OFF. If no faults are detected after the first-up time, it enters the Start/Restart state. To enter the Run state, the detection zone must be cleared and no faults are detected, and the operator must press and release the **Start** button (monitored start). If the XUSL4M safety light curtain system senses an object entering the detection zone when it is in Run state, the safety light curtain changes to Stop state and the safety outputs change from ON to OFF state.

After the obstruction is removed from the detection zone, the XUSL4M safety light curtain system changes to the Start/Restart state and the safety outputs stay at OFF state. To enter the Run state, the operator must press and release the **Start** button. If any obstruction is still present in the detection zone when you press and release the **Start** button, the XUSL4M safety light curtain system remains in the Stop state and the safety outputs remain in OFF state. If the detection zone is clear after the release of the **Start** button and no faults are detected, the XUSL4M safety light curtain system enters Run state and the safety outputs switch to ON state.

## XUSL4MB Manual Start/Restart

When OverRide1/RST (pin 10 of the main M12 12 pins connector) is connected to 24 Vdc through a **Start** pushbutton, the safety light curtain is configured in Manual Start/Restart mode.

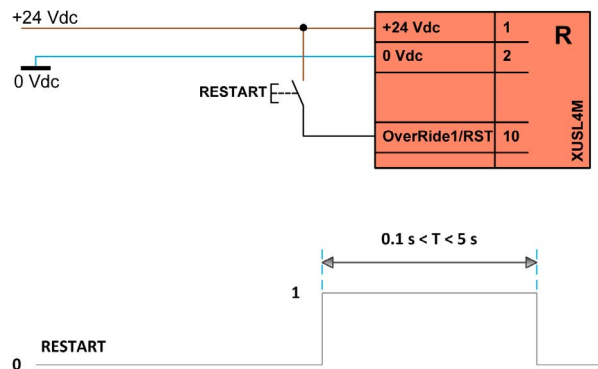

The high level (24 Vdc) must be maintained between 100 ms and 5 s. If the high level is maintained during more than 5 s, a new restart sequence will have to be repeated.

### **⚠ WARNING**

#### **UNINTENDED EQUIPMENT OPERATION**

Manual Start/Restart mode is mandatory:

- If the safety device controls an aperture to protect a hazardous zone.
- If a person remains in the hazardous zone without being detected after having passed through the aperture ("trip device" according to EN/IEC 61496-1).

The Restart command must be installed outside the hazardous zone in such way that the whole working and hazardous zones are observable. You must not access the Start/Restart command inside the hazardous zone.

**Failure to follow these instructions can result in death, serious injury, or equipment damage.**

### ***NOTICE***

#### **UNINTENDED EQUIPMENT OPERATION**

The Start/Restart command is effective after the operator has pressed and released the **Start** button, which means a transition sequence 0 Vdc --> 24 Vdc --> 0 Vdc is on the start command.

The duration of this sequence must be between 100 ms and 5 s.

**Failure to follow these instructions can result in equipment damage.**

**XUSL4MB Operating Modes**

The inputs SEL\_A and SEL\_B available to the XUSL4M receiver (main male connector - M12 - 12 pins) allow the configuration of the various operating modes.

It is therefore necessary to connect properly the XUSL4M receiver inputs for proper operation.

The following tables allow you to configure the type of muting to be adopted in terms of muting mode, timeout muting, override typology.

**Manual Start mode:**

SEL_A (pin 6)	SEL_B (pin 11)	Muting Type <sup>(1)</sup>	Muting timeout
24 Vdc (1)	OSSD1 (3)	4 sensors, sequence control	30 s
24 Vdc (1)	OSSD2 (4)	4 sensors, sequence control	∞
OSSD2 (4)	OSSD1 (3)	2 sensors, "TX" mode	30 s
OSSD1 (3)	OSSD2 (4)	2 sensors, "TX" mode	9 hrs
OSSD1 (3)	24 Vdc (1)	2 sensors, "L" mode	30 s
OSSD2 (4)	24 Vdc (1)	2 sensors, "L" mode	9 hrs
OSSD2 (4)	OSSD2 (4)	4 sensors, timing (or "Concurrent") control	30 s
OSSD1 (3)	OSSD1 (3)	4 sensors, timing (or "Concurrent") control	9 hrs
N.C./0 Vdc	N.C./0 Vdc	Configuration error	
N.C./0 Vdc	N.C./0 Vdc	XUSL4MA: Programming needed	

**(1)** For more details, refer to Muting Type Descriptions ([see page 34](#)).

**Automatic Start mode:**

SEL_A (pin 6)	SEL_B (pin 11)	Muting Type <sup>(1)</sup>	Muting timeout
24 Vdc (1)	24 Vdc (1)	4 sensors, sequence control	30 s
STATUS (12)	STATUS (12)	4 sensors, sequence control	∞
24 Vdc (1)	STATUS (12)	2 sensors, "TX" mode	30 s
STATUS (12)	24 Vdc (1)	2 sensors, "TX" mode	9 hrs
STATUS (12)	OSSD1 (3)	2 sensors, "L" mode	30 s
OSSD1 (3)	STATUS (12)	2 sensors, "L" mode	9 hrs
STATUS (12)	OSSD2 (4)	4 sensors, timing (or "Concurrent") control	30 s
OSSD2 (4)	STATUS (12)	4 sensors, timing (or "Concurrent") control	9 hrs
N.C./0 Vdc	N.C./0 Vdc	Configuration error	
N.C./0 Vdc	N.C./0 Vdc	XUSL4MA: Programming needed	

**(1)** For more details, refer to Muting Type Descriptions ([see page 34](#)).

**XUSL4MA Operating Modes**

The hardware configurations indicated for XUSL4MB are also applicable to XUSL4MA models. However, other settings can be configured thanks to the SoMute software ([see page 137](#)).

<i>NOTICE</i>
IMPROPER SETUP OR INSTALLATION
For allowing the programming mode, pin 6 and 11 of the 12 pins main connector on the receiver must be connected at 0 Vdc (or opened circuit) at power up.
Failure to follow these instructions can result in equipment damage.

### XUSL4MA Start/Restart Configuration

The choice between Manual and Automatic Start/Restart mode is possible thanks to SoMute software ([see page 156](#)).

#### Manual Start/Restart:

When OverRide1/RST (pin 10 of the main M12 12 pins connector) is connected to 24 Vdc through a **Start** pushbutton, the safety light curtain is configured in Manual Start/Restart mode.

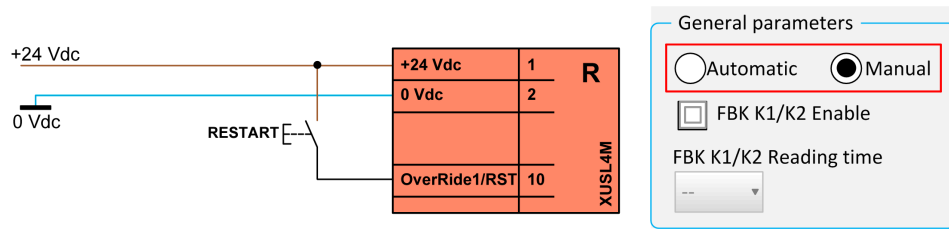

#### Automatic Start/Restart:

When OverRide1/RST (pin 10 of the main M12 12 pins connector) is not connected, the safety light curtain is configured in Automatic start/restart mode.

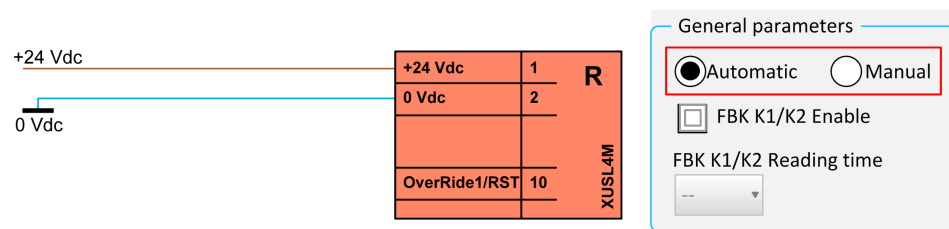

### XUSL4MA Muting Type Selection

The Muting type can be selected among the following list thanks to SoMute software ([see page 156](#)):

- L2X/L2P: Two Crossed Or Parallel Muting Sensors, Unidirectional Mode, Timing Control
- T2X: Two Cross Muting Sensors, Bidirectional, Timing Control
- T4P Seq: Four Parallel Muting Sensors, Bidirectional Mode, Sequential Control
- T4P Con: Four Parallel Muting Sensors, Bidirectional Mode, Timing (or “Concurrent”) Control

General parameters

Automatic    Manual

FBK K1/K2 Enable

FBK K1/K2 Reading time

500 ms ▾

Muting type

Muting T4P Seq ▾

## External Device Monitoring (EDM) or Machine Primary Control Element (MPCE) Monitoring

### General Description

EDM monitoring is an important safety function.

The EDM monitors the XUSL4M safety light curtain system interface to the guarded machine to:

- Confirm that the external devices such as switching devices like contactors are responding correctly to the XUSL4M safety light curtain outputs.
- Detect any inconsistency between the two external devices (that is, control relays) which could prevent a stop signal from reaching the machine primary control elements (for example, power contactors or electrovalve relays).

The EDM controls the external contactors KM1/KM2 connected to the two OSSDs. To achieve this, normally closed contacts of the external contactors (connected in series) are monitored. The control of the correct switching of KM1 and KM2 is performed 500 ms after the real command of the OSSDs.

To perform this function, the contactors KM1/KM2 must have:

- Normally closed mirror contact, according to EN/IEC 60947-4-1 (Annex F) for power contactors.
- Linked contacts (or force-guided contacts), according to EN/IEC 60947-5-1 (Annex L) or EN 50205 for auxiliary contactors or control relays.

### EDM Activated

XUSL4M awaits a signal with inverse logic to the condition of the external contactors:

- OSSD1 / OSSD2 ON: External contacts KM1/KM2 opened: **EDM = OPENED circuit**
- OSSD1 / OSSD2 OFF: External contacts KM1/KM2 closed: **EDM = CLOSED circuit**

**NOTE:** The time allowed from the deactivation of the OSSD outputs and the closing of the KM1/KM2 Feedback contacts must be  $T < 500$  ms.

Other timing setups are available on software programmable XUSL4MA model with SoMute software. For more information, refer to XUSL4MA EDM Parameters ([see page 31](#)).

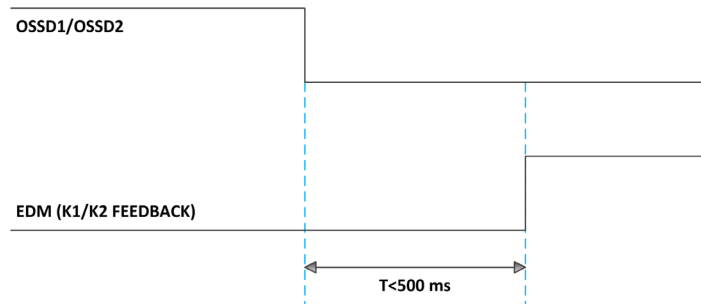

**NOTE:** The time allowed from the activation of the OSSD outputs and the opening of the KM1/KM2 contact is also monitored with the same time-out.

### XUSL4MB

The EDM function (external KM1/KM2 control) can be enabled/disabled via hardware:

EDM disabled

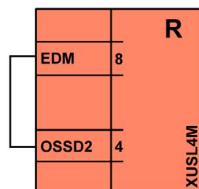

EDM enabled

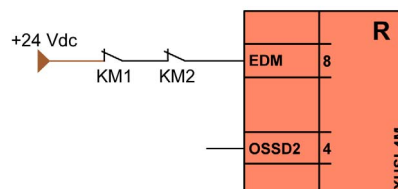

XUSL4MA

The EDM function (external KM1/KM2 control) can be enabled/disabled by hardware like XUSL4MB, but also with SoMute software:

EDM disabled

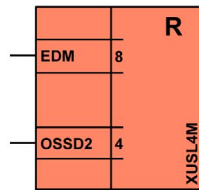

EDM enabled

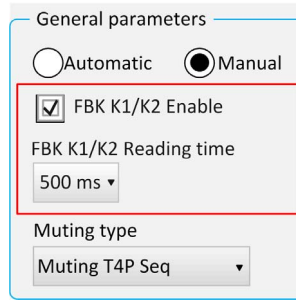
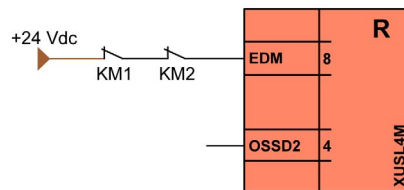

**FBK K1/K2 Reading time:**

Other values can be selected for the EDM loop monitoring. Allowed range: 100 ms...1300 ms (100 ms steps).

**NOTE:** K1 = KM1, K2 = KM2

## Test Function

### General Description

Few applications require the machine guarding system to be tested by the machine controller during a non-hazardous portion of the machine cycle. This is to verify that the guarding system is functioning properly.

To trigger the test functions connect pins 2 and 4 on the transmitter at 0 Vdc (by using potential free contact).

When the transmitter senses a 0 Vdc on these pins, a beam blocked state is simulated (as if the protected zone was occupied) and the receiver enters the Stop state. The beam blocked state is simulated as long as the pins 2 and 4 are connected to 0 Vdc.

An external control unit (for example, a PLC) can thus check the correct operation of the entire system, by monitoring the connected downstream equipment. without physically entering the protected zone).

By using this function, the OSSDs can be switched from ON to OFF as long as the function remains active.

<b><i>NOTICE</i></b>
----------------------

<b>UNINTENDED EQUIPMENT OPERATION</b>
---------------------------------------

The test command duration must be at least 40 ms.
---

<b>Failure to follow these instructions can result in equipment damage.</b>
---

The XUSL4M safety light curtain system features an automatic self-diagnosis function that enables it to detect response time failure (this time is declared for each model).

**NOTE:** In normal operation, this self diagnosis is permanently active and does not require any interventions from the outside.



## Maximum Sensing Distance Selection

### General Description

Two different maximum sensing distances (low range and high range) can be selected for XUSL4M safety light curtains.

This table displays the sensing range selection:

Models	Sensing range selection	Detection	
		Hand	Body
Standard range	Low range: 0...4 m High range: 0...12 m	✓	✓

To select the Low range or High range, refer to the Transmitter Connections ([see page 95](#)).

## Section 2.3

### Muting Functions

---

#### Overview

This section describes the muting functions of the safety light curtain.

#### What Is in This Section?

This section contains the following topics:

Topic	Page
Muting Type Description	<a href="#">35</a>
Two Crossed or Parallel Muting Sensors, Unidirectional Mode (L2X/L2P), Timing Control	<a href="#">37</a>
Two Cross Muting Sensors, Bidirectional (T2X), Timing Control	<a href="#">41</a>
Four Parallel Muting Sensors, Bidirectional Mode (T4P) Timing (or “Concurrent”) Control and Sequential Control	<a href="#">45</a>
Muting Enable	<a href="#">48</a>
Partial Muting	<a href="#">50</a>
Muting Override	<a href="#">53</a>

## Muting Type Description

### General Requirements

The following information must be known before the utilization of the safety light curtain:

- The Muting function is a temporary suspension of the safety function that needs to be activated and deactivated automatically.
- The activation and subsequent deactivation of the Muting function must take place only by using two or more wired and independent signals activated by a correct timing or spatial sequence. This means that a single failure cannot activate the Muting function.
- It must not be possible to activate the Muting function when XUSL4M has deactivated the safety outputs.
- It must not be possible to start a Muting function by switching off and then restarting the device.
- Muting must be activated at an appropriate point of the machine cycle, that is, only when there are no risks for the operator.
- Muting sensors must be mechanically protected so that any impact does not modify their alignment.
- When used, make sure that the MUTING/OVERRIDE signal lamp is correctly installed in a visible location by the operator.

### Selection and Orientation of Muting Sensors

Select and orient the muting sensors so that they recognize the presence of the work piece as the condition for starting or stopping the muting sequence. The presence of any person in the detection zone of the muting sensors must never initiate a muting sequence.

The proper selection, installation, and orientation of the muting sensors are the sole responsibility of the employer and installer.

## WARNING

### UNINTENDED EQUIPMENT OPERATION

- The incorrect setting of the Muting parameters compromises the safe operation of the safety system.
- If the distance between the muting sensors is lower than required, the safety function is not guaranteed.

**Failure to follow these instructions can result in death, serious injury, or equipment damage.**

The following requirements must be observed, especially in applications involving conveyors:

- Ensure that the muting sensors detect the material, and not the transportation means, such as a pallet, cart, or other transport device.
- Ensure that a person on the transport device cannot initiate muting and enter the hazardous zone.
- Do not allow interruption in the sensing of the material while the material passes the muting sensors. The detection of the material must be continuous over its length (filtering options are available with SoMute software).
- When using photoelectric sensors, do not allow reflective material to interrupt or cause optical paths among different sensors. Do not allow sensors in adjacent zones to interfere with each other or provide false indication.
- Depending on the Muting configuration, position the sensors such that before a new material is detected by the sensors, the previous material has passed the sensors, and all muting sensors are deactivated for a time.
- Consider the overall speed and cycle of the material as it moves through the process. Allow time for evaluating the muting sensor outputs before the material reaches the safeguarding device.
- Detect and prevent people from entering the hazardous zone of the machine. The safeguarding device must be able to send a stop signal to the machine before a person enters the hazardous zone. Other safeguarding methods, such as physical barriers or fences, may be necessary.
- The detection zone of the muting sensors must be adjusted at a height suitable to detect a person's leg(s).

- The height of the muting sensors from the plane of the conveyor should be such as to detect the load being conveyed, but not the pallet or the transport unit.

<b><i>NOTICE</i></b>
----------------------

<b>UNINTENDED EQUIPMENT OPERATION</b>
---------------------------------------

For the detection of unconventional shape objects (for example objects with possible detection holes like piles of pallets), pre-built muting arms equipped with multibeam (5 beams) muting sensors are available as well as individual multibeam (5 beams) muting sensors.
---

<b>Failure to follow these instructions can result in equipment damage.</b>
---

For more detail, refer to muting arms with multibeam muting sensors description. ([see page 87](#))

## Two Crossed or Parallel Muting Sensors, Unidirectional Mode (L2X/L2P), Timing Control

### General Description

In these muting types, sensors 1 and 2 are on the same side and are placed inside the hazardous zone. This mode is unidirectional and can be used to allow materials to exit from the hazardous area while preventing any entry in the hazardous area.

The activation of the Muting function occurs after the interruption (within 4 s maximum) of S1 and S2 sensors. As long as both sensors remain interrupted, the Muting function continues. When the first of the two sensors is released, the material still has 4 seconds to leave the protected zone limited by the safety light curtain. The Muting condition is disabled as soon as the protected zone is cleared.

At the end of 4 seconds, if the safety light curtain is still interrupted, the OSSD outputs are disabled, thus interrupting the operation of the machine. The maximum duration of the Muting condition (timeout) is configurable as 30 seconds or 9 hours.

**NOTE:** Other timing setups are available on software programmable XUSL4MA model with SoMute software. For more information, refer to Muting Parameters ([see page 157](#)).

L2X and L2P muting types impose constraints on the distance between two consecutive objects.

### ⚠ WARNING

#### IMPROPER MUTING UTILIZATION

For the safe operation of the L2X or L2P configurations, the horizontal Muting sensor elements must be located within the hazardous zone.

**Failure to follow these instructions can result in death, serious injury, or equipment damage.**

### L2X Muting type with XUSZASL2XT pre-built muting arms

The L2X configuration is as follows:

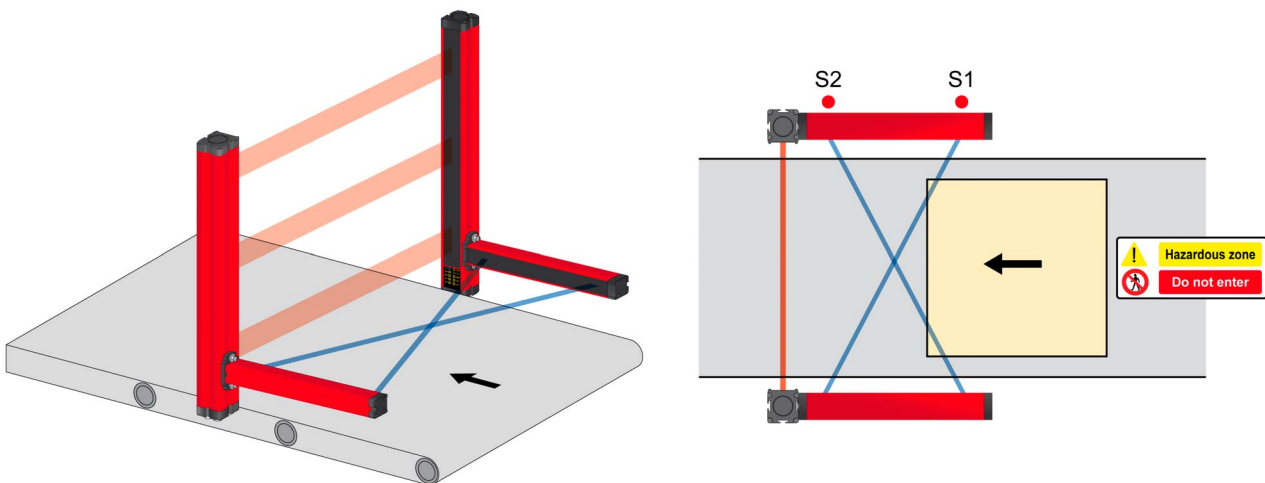

### ⚠ WARNING

#### IMPROPER MUTING UTILIZATION

When using XUSZASL2XT pre-built muting arms, the minimum distance between two consecutive objects must be less than 10 cm (3.94 in) or greater than 32 cm (12.60 in).

The position of the object on the conveyor and its dimensions must be such as they fulfill all necessary requirements of the expected muting sequence.

**Failure to follow these instructions can result in death, serious injury, or equipment damage.**

### L2P Muting type with XUSZASL2PP pre-built muting arms

The L2P configuration is as follows:

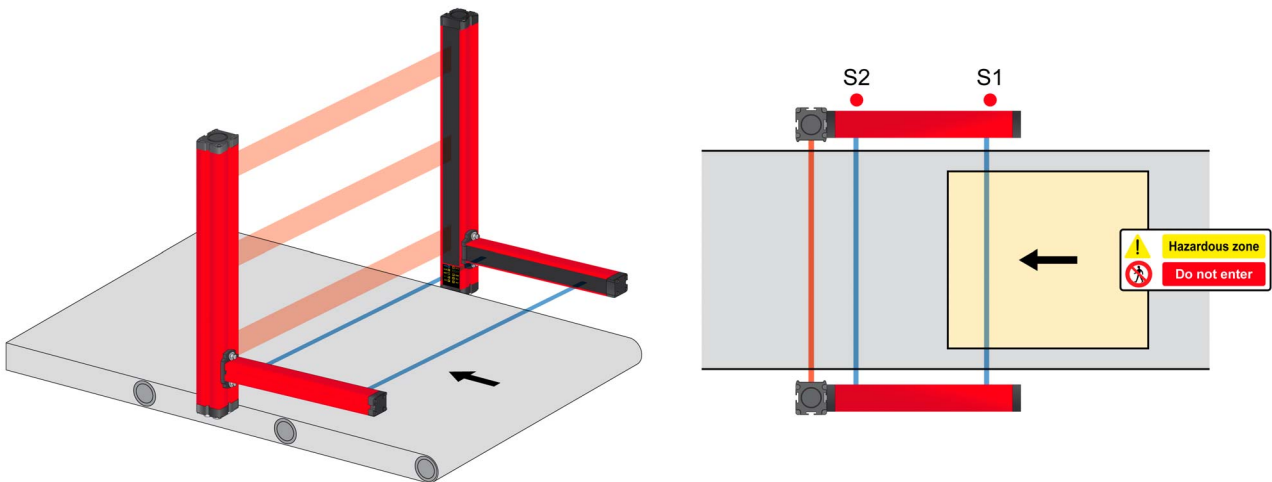

## **⚠ WARNING**

### **IMPROPER MUTING UTILIZATION**

- When using XUSZASL2PP and XUSZASL2PPT (suitable for transparent object detection) pre-built muting arms, the minimum distance between two consecutive objects must be 0 cm (0 in) or greater than 40 cm (15.75 in).  
The minimum object length is 40 cm (15.75 in) in order to ensure simultaneous occupancy of the two muting sensors and the protected area limited by the safety light curtain.
- When using XUSZASL2PPS pre-built muting arms for high speed conveyors (linear speed > 25m/min), the minimum distance between two consecutive objects must be greater than 45 cm (17.72 in).  
In that case, the minimum object length is 45 cm (17.72 in).

**Failure to follow these instructions can result in death, serious injury, or equipment damage.**

**NOTE:** For L2P muting type, there is no constraints on the object position on the conveyor.

### L2X/L2P Muting type with external individual muting sensors

Instead of pre-built muting arms, the use of external individual muting sensors is possible with the proviso that they are compatible with the XUSL4M muting sensor inputs. In that case, the most commonly used muting sensors are photocells. The photocells must have Normally Open (NO) PNP output (see XU range from Telemecanique).

L2X configuration with external individual muting sensors:

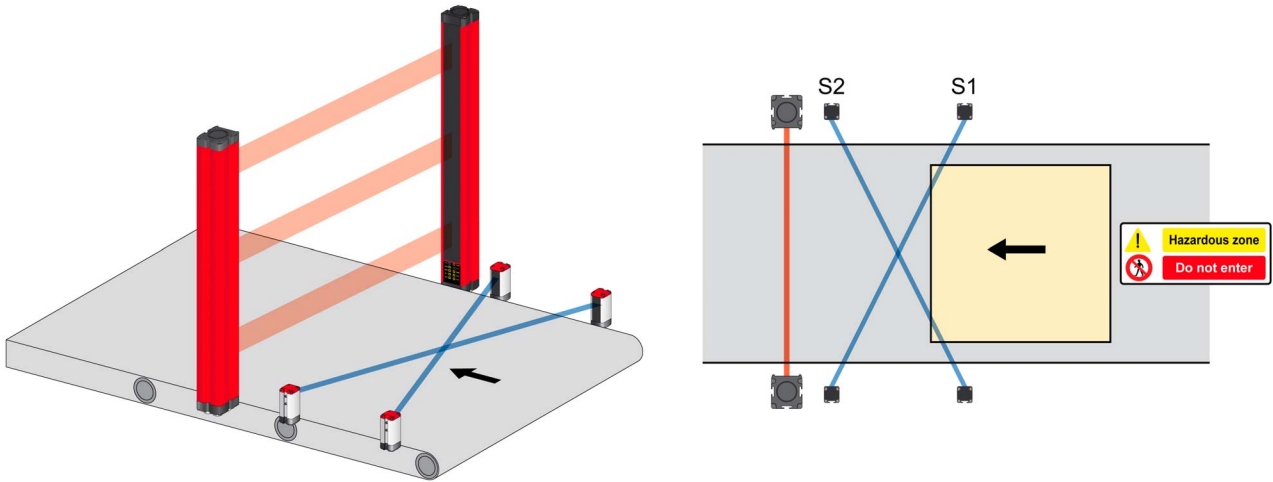

L2P Configuration with external individual muting sensors:

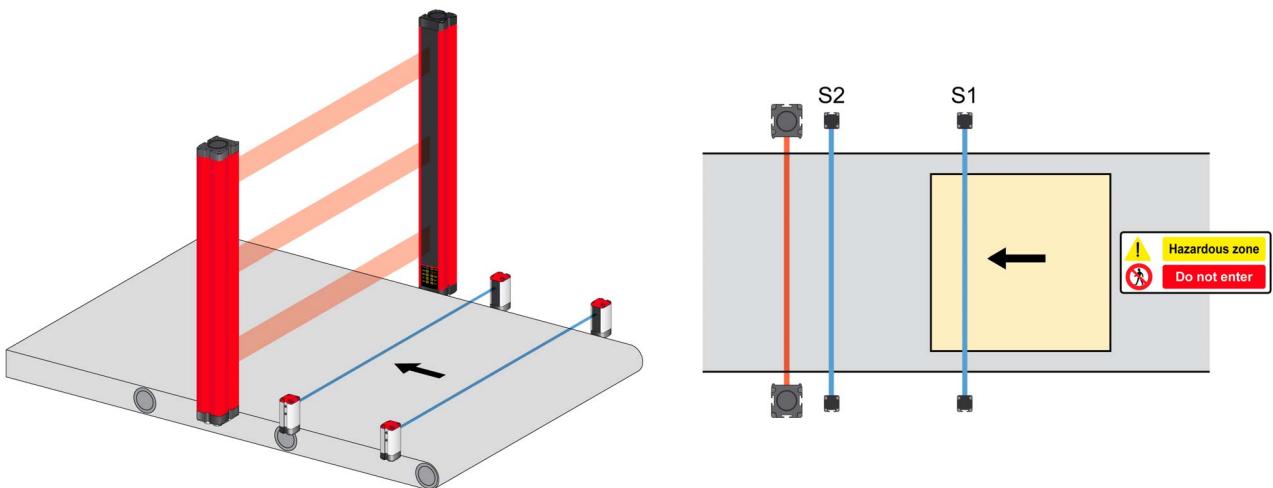

The distance to be respected between two consecutive objects and their minimum length depends on the muting sensors positioning as well as the maximum speed of the conveyor (for which the muting sensors response time has to be considered). As their position can be adjusted inside their support, this remark also applies for the muting sensors implemented in multibeam muting arms XUSZAML2XP and XUSZAML2PTS.

## **⚠ WARNING**

### **UNINTENDED EQUIPMENT OPERATION**

When using individual muting sensors or multibeam muting arms XUSZAML2XP and XUSZAML2PTS, the muting sensors positioning must be carefully specified and suitable for the application in order to guarantee the safe operation of the safety system.

**Failure to follow these instructions can result in death, serious injury, or equipment damage.**

**L2X/L2P Timing Diagrams**

In the following timing diagram, the muting function is terminated when the detection zone of the safety light curtain is clear (the 4 s timer has not expired):

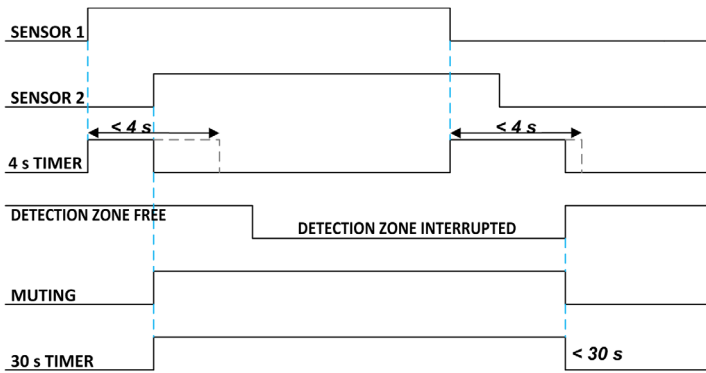

In the following timing diagram, the muting function is terminated by the 4 s timer because when it expires, the detection zone of the safety light curtain remains interrupted:

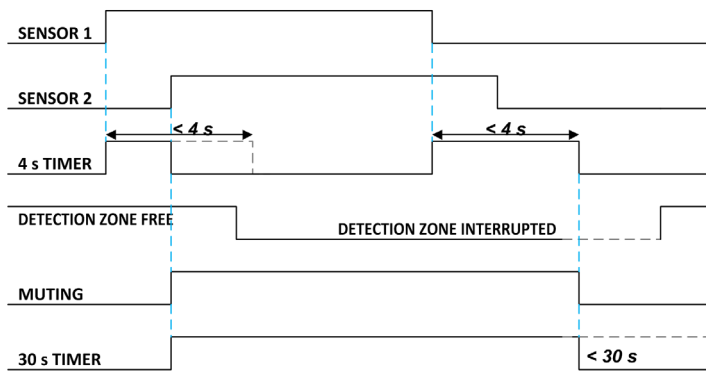

In the following timing diagram, the muting cycle is terminated by the muting timeout:

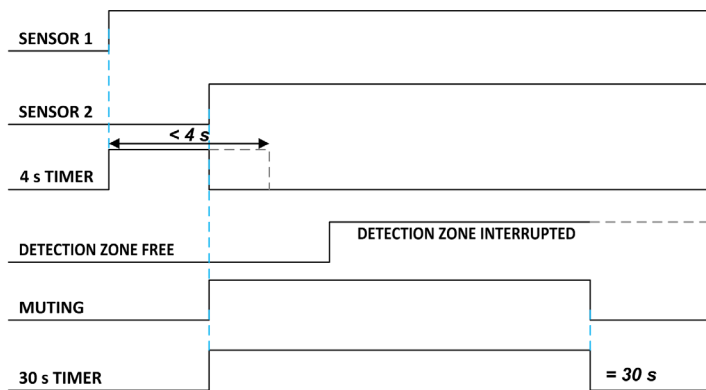



## Two Cross Muting Sensors, Bidirectional (T2X), Timing Control

### General Description

In this muting type, the two Muting sensors are cross-mounted on each side of the safety light curtain. This mode is bidirectional: if the conveyor movement is reversed when the muting function is active, as soon as one of the sensors S1 or S2 is deactivated, the muting function is disabled. The system can thus work in both directions (entry and exit).

### WARNING

#### IMPROPER MUTING UTILIZATION

The crossing point of the two Muting sensors must be placed inside the hazardous zone. The distance from the protected area must be as short as possible in order to avoid that persons entering the hazardous zone immediately after the object or the transport system be undetected. For more details, refer to Positioning the Crossing Point of Two Individual Muting Sensors ([see page 43](#)).

**Failure to follow these instructions can result in death, serious injury, or equipment damage.**

The activation of the Muting function occurs after the interruption (within max 4 s) of sensors S1 and S2. As long as both sensors remain interrupted, the Muting function continues. By releasing the first of the two sensors, the Muting function is disabled. This mode also allows selecting the maximum duration of the Muting condition (timeout) as 30 seconds or 9 hours.

**NOTE:** Other timing setups are available on software programmable XUSL4MA model with SoMute software. For more information, refer to Muting Parameters ([see page 157](#)).

**NOTE:** This Muting type allows continuous flow of objects. However, it imposes constraints on the object size to be detected and its position on the conveyor.

**T2X Muting type with XUSZAST2XT pre-built muting arms**

The T2X configuration is as follows:

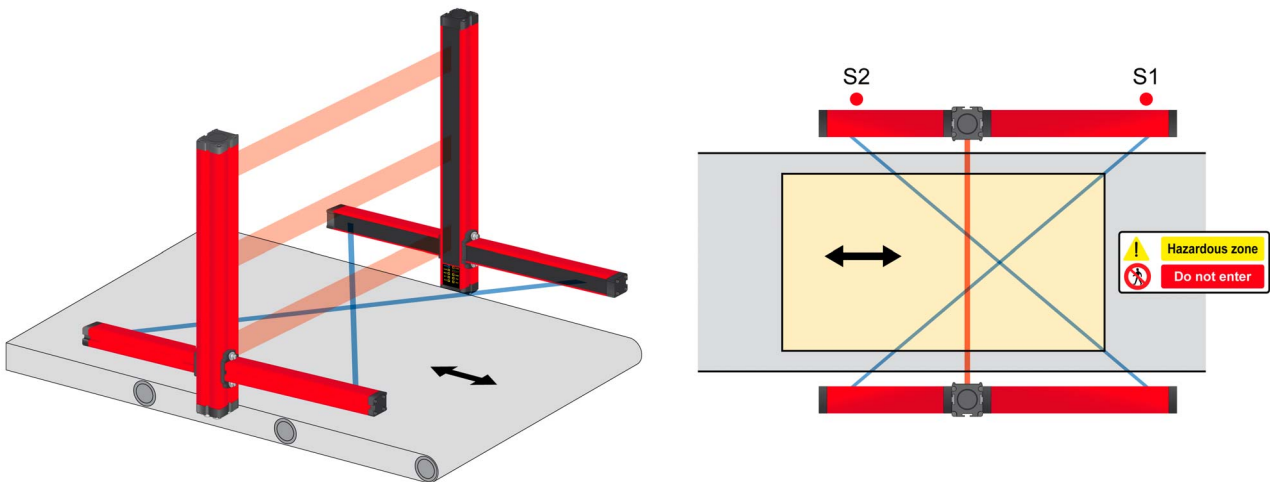

Instead of pre-built muting arms, the use of external individual muting sensors is possible with the proviso that they are compatible with the XUSL4M muting sensor inputs. In that case, the most commonly used muting sensors are photocells. The photocells must have Normally Open (NO) PNP output (see XU range from Telemecanique).

For more information, refer to Positioning Two Individual Muting Sensors ([see page 43](#)) and Positioning the Crossing Point of Two Individual Muting Sensors ([see page 44](#)).

As their position can be adjusted inside their support, this information on the crossing point positioning also applies for the muting sensors implemented in multibeam muting arms XUSZAMT2XP.

**⚠ WARNING**

**UNINTENDED EQUIPMENT OPERATION**

When using individual muting sensors or multibeam muting arms XUSZAMT2XP, their positioning must be carefully specified and suitable for the application in order to guarantee the safe operation of the safety system.

**Failure to follow these instructions can result in death, serious injury, or equipment damage.**

### T2X Timing Diagrams

In the following timing diagram describes a normal operation for two crossed beams:

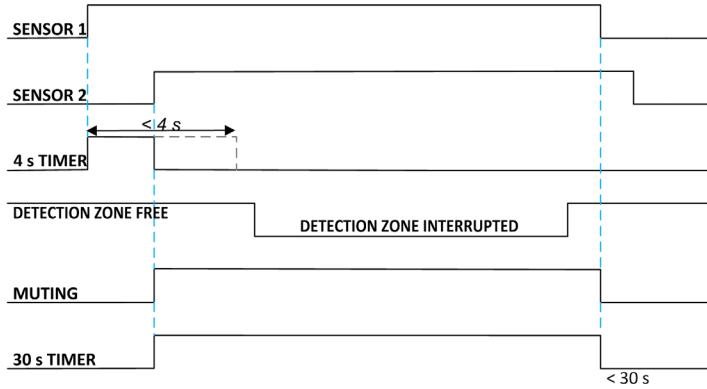

In the following timing diagram, the muting cycle is terminated by the muting timeout:

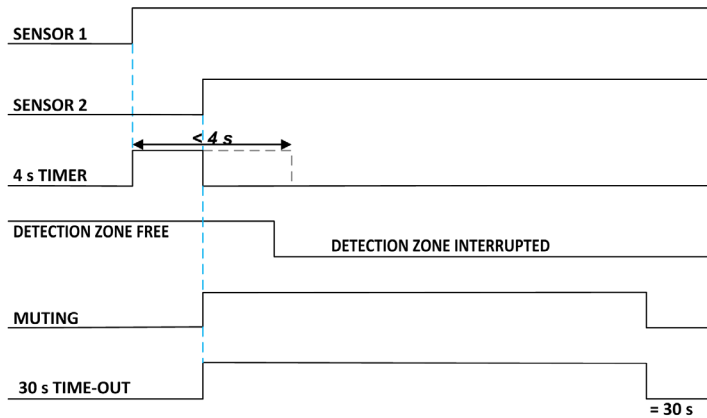

### Positioning Two Individual Muting Sensors

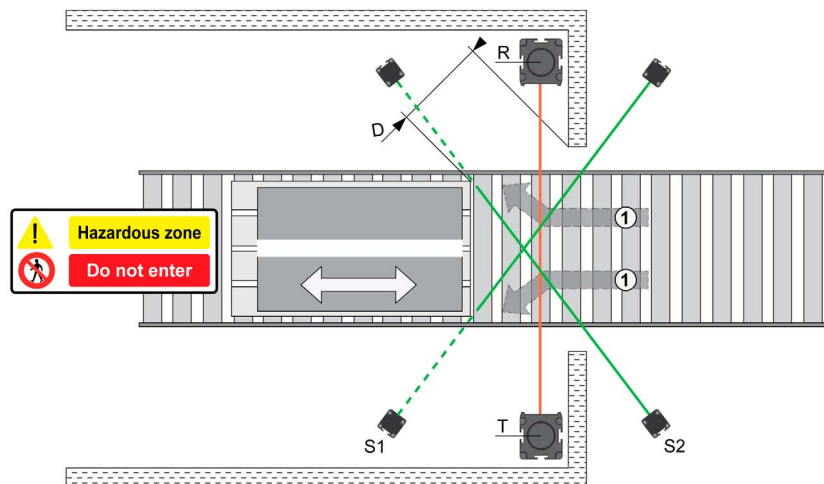

**S1-S2** Muting sensors

**R** Receiver of the Safety light curtain

**T** Transmitter of the Safety light curtain

**D** Path width to the Safety light curtain as the muting sequence starts

**1** Possible ways of intrusion while the pallet is crossing the muting zone

**The installation must respect:  $D < 200\text{ mm}$  (7.87 in).**

**D** depends on the position of the muting sensors S1 and S2 and the location of the fences or physical barriers.

In this example, considering  $D > 200\text{ mm}$  (7.87 in), there are possible ways of intrusion (1) while the muting function is triggered. Personnel can thus access the hazardous zone without stopping the machine.

**NOTE:** Refer to IEC TS 62046 for more muting operation details.

### Positioning the Crossing Point of Two Individual Muting Sensors

The following illustration presents a conveyor belt muting system using an external two-sensors configuration and access restriction to the hazardous zone:

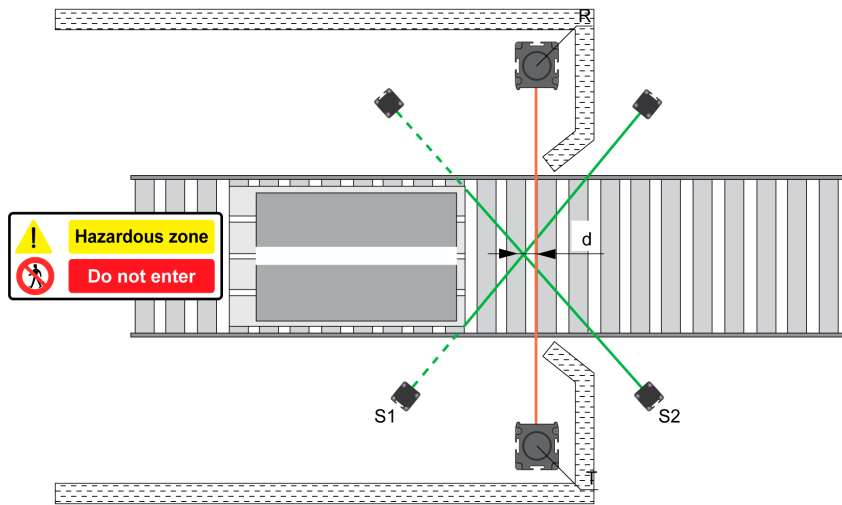

**S1-S2** Muting sensors

**R** Receiver of the Safety light curtain

**T** Transmitter of the Safety light curtain

**d** Distance between the Safety light curtain beam and the muting sensors crossing point.

**The installation must respect:  $d < 200 \text{ mm (7.87 in)}$ .**

The crossing point of the two light beams S1 and S2 must be located behind the detection zone of the Safety light curtain in direction of the hazardous zone.

The distance **d** must be shorter than 200 mm (7.87 in) to avoid personnel entering the hazardous zone without been detected.

## Four Parallel Muting Sensors, Bidirectional Mode (T4P) Timing (or “Concurrent”) Control and Sequential Control

### General Description

This mode is bidirectional. The system can thus work in both directions (entry and exit).

Using this mode, two different modes of operation are available:

- Timing (or “Concurrent”) control
- Sequential control

**NOTE:** These Muting types impose constraints on the object length to be detected and the distance between 2 objects.

### T4P Muting type with XUSZAST4PP pre-built muting arms

The T4P configuration is as follows:

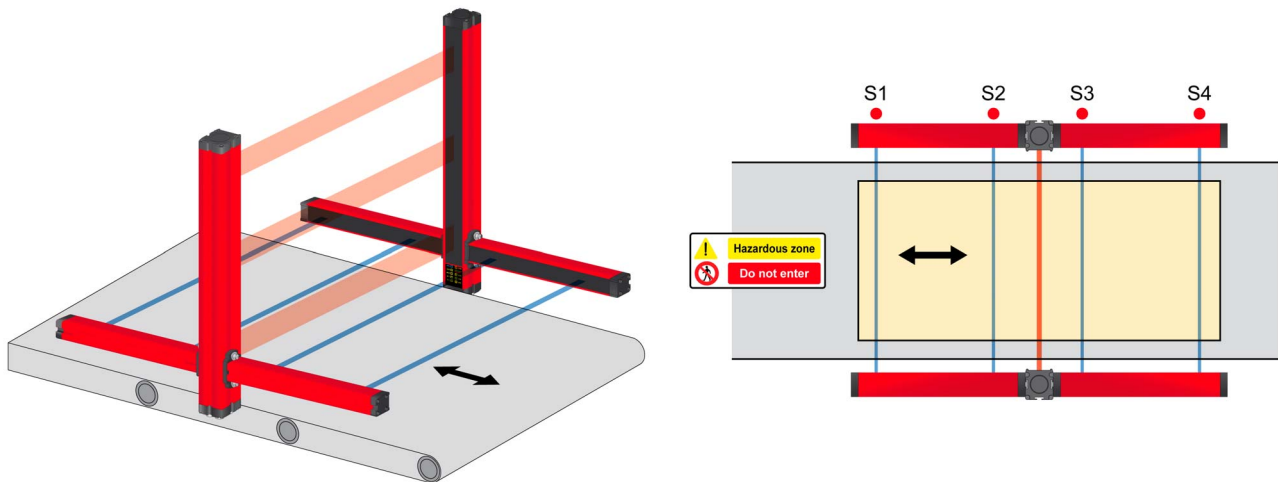

## ⚠ WARNING

### IMPROPER MUTING UTILIZATION

- When using XUSZAST4PP, XUSZAST4PPT and XUSZAMT4PT pre-built muting arms, in both modes of operation, the minimum object length and the distance between two objects must be 75 cm (29.53 in) in order to ensure simultaneous occupancy of all four sensors.
- When using XUSZAST4PPS and XUSZAMT4PTS pre-built muting arms for high speed conveyors, in both modes of operation, the minimum object length and the distance between two objects must be 90 cm (35.43 in) in order to ensure simultaneous occupancy of all four sensors.

**Failure to follow these instructions can result in death, serious injury, or equipment damage.**

### Timing (or “Concurrent”) Control

The activation of the Muting function occurs after the sensors S1 and S2 are interrupted (within max 4 s) or S4 and S3 with material moving in the opposite direction and maintained by the 2 sensors S3 and S4 (or S2 and S1 in the opposite direction). It means that during a certain time, the 4 muting sensors are interrupted. The Muting state ends after the release of the safety light curtain, and of the S3 sensor (or S2 with material moving in the opposite direction). Before a new muting sequence, all muting sensors must be cleared.

For the T4P models, there are two available Muting timeouts:

- 30 seconds
- 9 hours

Timing diagram showing four beams with timing control:

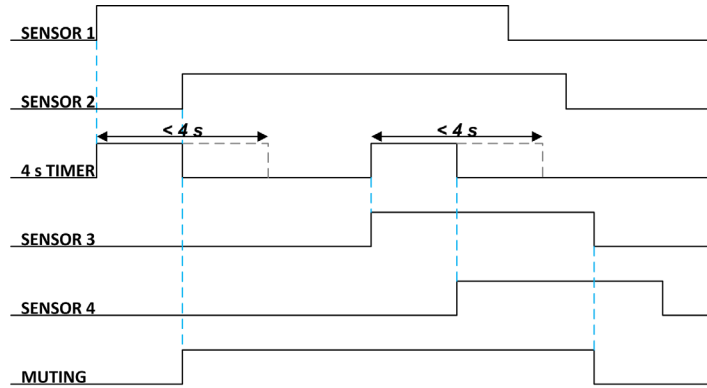

### Sequential Control

The activation of the Muting function occurs after the sequential interruption of sensors S1 and S2 (or S4 and S3 with material moving in the opposite direction) without time limitations. During a certain time, the 4 muting sensors are interrupted. The Muting state ends after the release of the safety light curtain, and of the S3 sensor (or S2 with material moving in the opposite direction). Before a new muting sequence, all muting sensors must be cleared.

For the T4P models, there are two available Muting timeouts:

- 30 seconds
- Infinite

**NOTE:** Other timing setups are available on software programmable XUSL4MA model with SoMute software. For more information, refer to Muting Parameters ([see page 157](#)).

Timing diagram showing four beams with sequence control:

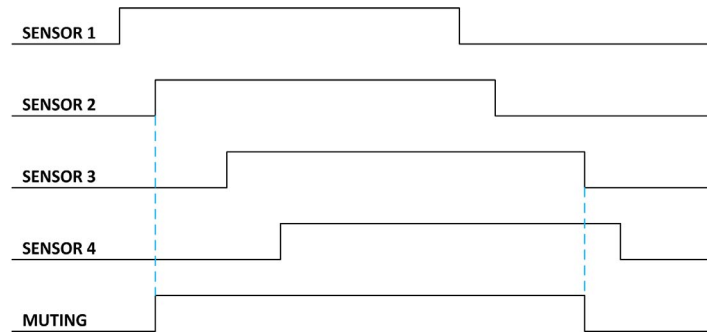

XUSL4M status; sequence control:

Sensor 1	Sensor 2	Sensor 3	Sensor 4	XUSL4M Status
0	0	0	0	Active
1	0	0	0	Active
1	1	0	0	Muted
1	1	1	0	Muted
1	1	1	1	Muted
0	1	1	1	Muted
0	0	1	1	Muted
0	0	0	1	Active
0	0	0	0	Active

Monitoring the interruption of the safety light curtain within the sequence can provide improved resistance to manipulation or bypassing.

**T4P Muting type with external individual muting sensors**

Instead of pre-built muting arms, the use of external individual muting sensors is possible with the proviso that they are compatible with the XUSL4M muting sensor inputs. In that case, the most commonly used muting sensors are photocells. The photocells must have Normally Open (NO) PNP output (see XU range from Telemecanique)

**NOTE:** The use of individual external photoelectric muting sensors with background suppression on alternate sides of the transport system is recommended in order to avoid manipulation of the muting function by, for example, using a piece of cardboard with the same length as the material being transported. Other useful methods for avoiding a manipulation of the muting function are given in the IEC TS 62046.

The distance to be respected between two consecutive objects and the minimum object length will depend on the muting sensors positioning.

**⚠ WARNING**

**UNINTENDED EQUIPMENT OPERATION**

When using individual muting sensors, their positioning must be carefully specified and suitable for the application in order to guarantee the safe operation of the safety system.

**Failure to follow these instructions can result in death, serious injury, or equipment damage.**

T4P configuration with external individual muting sensors:

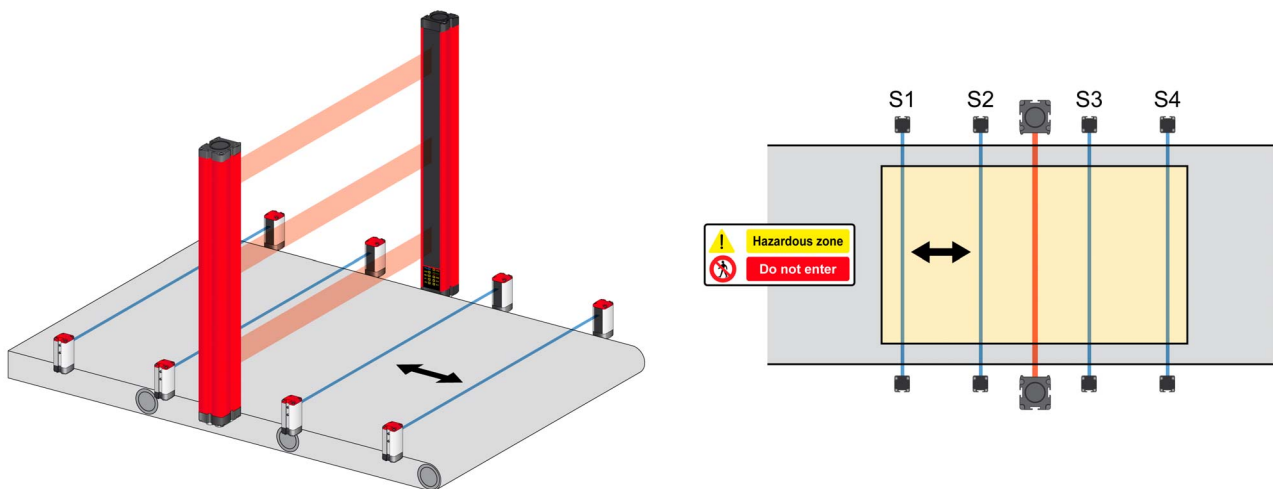

## Muting Enable

### General Information

There are different ways to enable and disable the muting function:

- When MUT\_ENABLE is disabled, the muting function is always activated:
  - The muting function starts and ends after the correct sequence or timing of the muting sensors.
- The muting function can also be enabled only after a rising edge is generated on the MUT\_ENABLE input:
  - The muting function starts after a rising edge signal on the MUT\_ENABLE pin (pin 7 on the receiver) AND a correct sequence or timing of the muting sensors.
  - The muting function ends after the correct sequence or timing of the muting sensors.

Operation:

Muting Enable Function	Description
Disabled	The muting cycle is always enabled (without considering the muting enable signal)
Enabled	The muting cycle is enabled only after the correct transition (rising edge) of the muting enable signal (see figure below) and ends after the correct sequence or timing of the muting sensors.

### XUSL4MB

Pin 7 (MUT\_ENABLE) and 12 (STATUS) of M12 12-pin connector on the receiver must be connected as indicated:

MUT\_ENABLE disabled

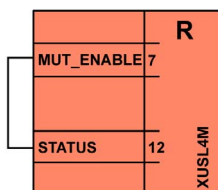

MUT\_ENABLE enabled

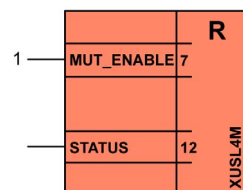

1 Muting Enable external signal

### XUSL4MA

The muting enable function can be configured with SoMute software. If so, pin 7 (MUT\_ENABLE) and 12 (STATUS) of M12 12-pin connector on the receiver must be connected as indicated:

MUT\_ENABLE disabled

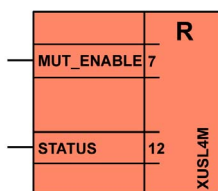

MUT\_ENABLE enabled

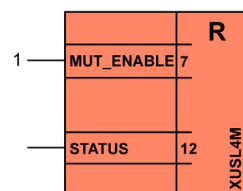

1 Muting Enable external signal

Thanks to the programming software, when **with enable** is selected, the muting enable function can be of two types:

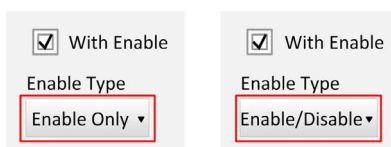



- When **Enable only** is selected:
  - the muting function starts after a rising edge signal on the MUT\_ENABLE pin and a correct sequence or timing of the muting sensors
  - the muting function ends after the correct sequence or timing of the muting sensors

Refer to Muting Enable timing diagram ([see page 49](#)).

**NOTE:** The function activation only applies to a single muting cycle; It is therefore necessary to return MUT\_ENABLE signal to 0V before any new "With Enable" Muting function request.

- When **Enable/Disable** is selected:
    - the muting function starts as when Enable only is selected
    - the muting function ends after a falling edge on the MUTING\_ENABLE input
- Refer to Muting Enable/Disable timing diagram ([see page 49](#)).

### Muting Enable Timing Diagram

Muting Enable active, correct muting sequence:

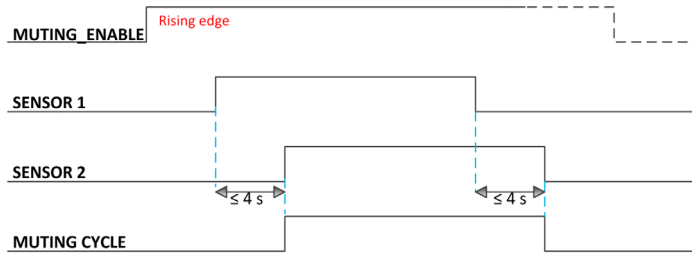

### Muting Enable/Disable Timing Diagram

Muting Enable/Disable active, correct muting sequence:

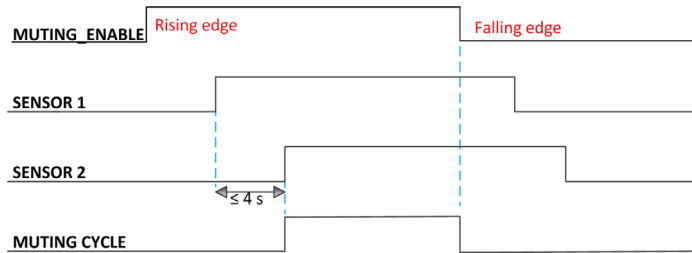

## Partial Muting

### General Description

The Partial Muting feature allows to limit the Muting function to a number of well-defined beams.

Thanks to this function, you can enable the Muting function only for those beams that are interrupted by the passage of the material (for example: lower pallets at the end of the product cycle). The remaining beams, however, can be kept active to protect the hazardous zone.

Partial muting also avoid the possibility to climb onto the object without being detected.

**NOTE:** This function is only available on XUSL4MA models and must be configured through the SoMute software (select **Partial Muting Enable**).

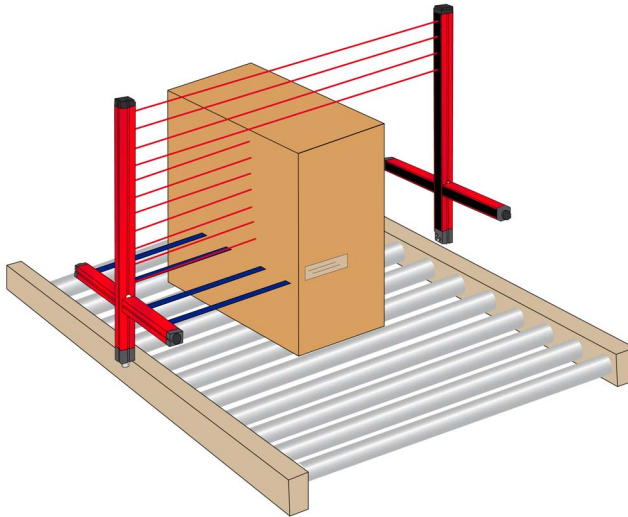

The number of beams affected by Partial Muting is selectable through SoMute software, knowing that the first Partial Muting beam always starts from the bottom (connectors side).

For this operation, it may be interesting to use the Monitor software function ([see page 52](#)).

Only one value can be entered when programming the number of beams affected by this function.

There are two types of partial Muting and, for both, the “Partial Muting” input pin (pin 6 of the M12 12-pin connector on the receiver) must be used.

Two types of Partial Muting are available for programming Partial Muting function:

- Partial Muting With Enable ([see page 51](#))
- Partial Muting With Disable ([see page 51](#))

### **NOTICE**

#### **IMPROPER SETUP OR INSTALLATION**

For allowing the programming mode, pin 6 and 11 of the 12-pin main connector on the receiver must be connected at 0 Vdc (or opened circuit) at power-up.

**Failure to follow these instructions can result in equipment damage.**

**NOTE:** To set this function correctly, refer to the XUSL4MA Operating Modes ([see page 28](#)).

### Partial Muting With Enable

With this option, the Partial Muting function is deactivated. To activate this function, the input signal (pin 6 of the receiver) must switch from LOW to HIGH (rising edge) before starting the next Muting cycle for which a partial muting is requested. The rising edge on this input signal enables the Partial Muting function only for the first n selected beams (for example with 10 beams as in figure below).

**NOTE:** This activation only applies to a single muting cycle; It is therefore necessary to reconfirm Partial Muting activation before any new Muting function request (refer to the timing below).

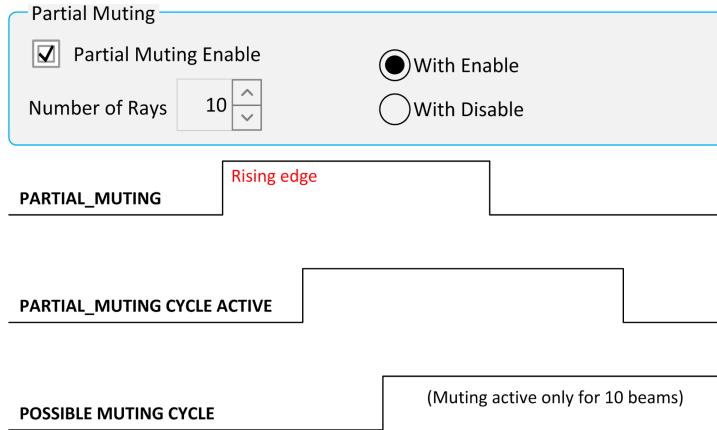

### Partial Muting With Disable

With this option, the Partial Muting function is normally active (for example with 10 beams as in figure below) and the partial muting function starts after the correct sequence or timing of the muting sensors. To disable/deactivate the partial muting function, the input signal (pin 6 of the receiver) must switch from LOW to HIGH (rising edge) before starting the next Muting cycle for which a full muting is requested. A rising edge on that input signal therefore disables the Partial Muting function and the muting for all beams is then configured for the next muting cycle.

**NOTE:** This activation only applies to a single muting cycle; It is therefore necessary to reconfirm the Partial Muting deactivation before any new full Muting function request (refer to the timing below).

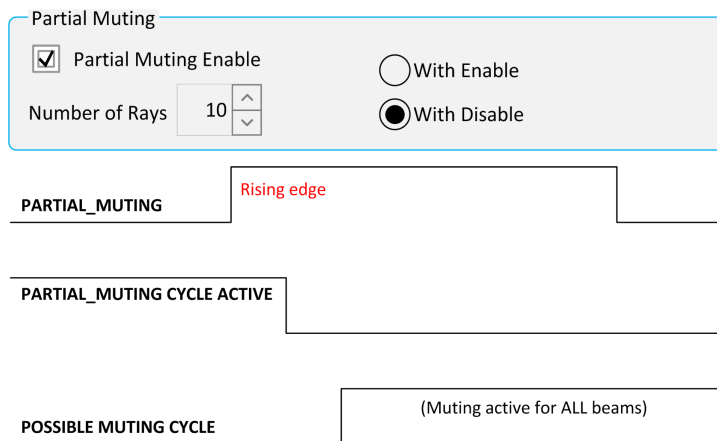



### Partial Muting: Monitor

Free beams are indicated by a different color than the interrupted ones and various numerical information<sup>(1)</sup> are displayed:

- LBO: Last Beam Obstructed
- FBO: First Beam Obstructed
- CBO: Central Beam Obstructed
- NBO: Number of Beams Obstructed
- NCBO: Maximum Number of Consecutive Beams Obstructed

(1) Available only on 30 mm and 40 mm resolution XUSL4MA models.

Dynamic reading of the safety light curtain condition:

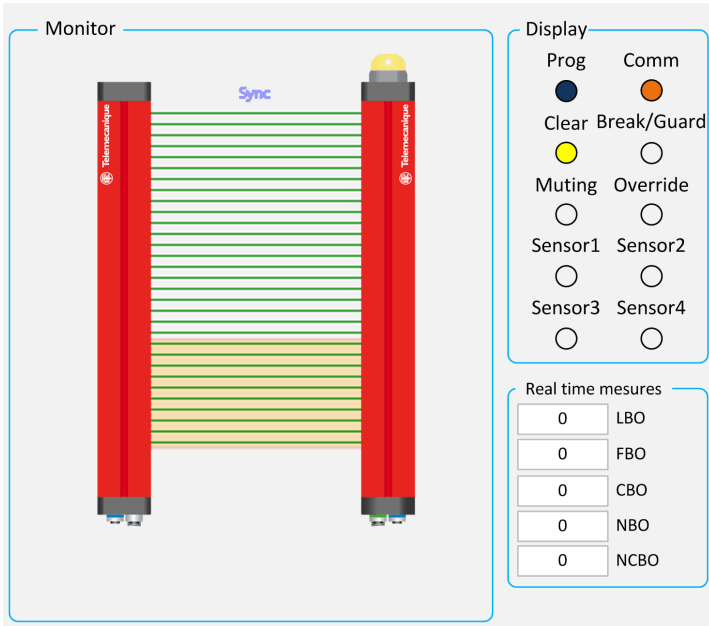

Partial muting monitoring provide a dynamic reading of the safety light curtain condition:

- A graphical representation of the safety light curtain, with highlighted beams for Partial muting function (the beams with partial muting function are highlighted in yellow, while green colored beams work normally (they stay active and if at least one of them is interrupted, the OSSDS will drop to OFF state)
- A representation of the signaling label with real time display
- A representation of the integrated lamp with real time color display

## Muting Override

### General Description

The OVERRIDE is a forced activation of OSSD outputs. This function becomes necessary when, after incorrect Muting activation sequences, the machine stops, leaving the material in the hazardous zone.

In this situation, the OSSD outputs are inactive because the safety light curtain and/or at least one Muting sensor are interrupted. In this condition, the OVERRIDE LED flashes.

The OVERRIDE command activates the OSSD outputs to remove the material obstructing the safety light curtain and/or the muting sensor(s).

XUSL4M allows you to configure two different types of OVERRIDE:

- Override with spring return key command (Hold-to-run action control)
- Override with push button command (Pulse action control)

### WARNING

#### UNINTENDED EQUIPMENT OPERATION

During the entire phase during which the OVERRIDE function is active, the OVERRIDE/MUTING lamp flashes. You must periodically verify the efficiency of this lamp (during MUTING or OVERRIDE phases).

**Failure to follow these instructions can result in death, serious injury, or equipment damage.**

### WARNING

#### UNINTENDED EQUIPMENT OPERATION

The Pulse OVERRIDE command automatically activates the safety light curtain outputs until both the safety light curtain and the Muting sensors are again free of obstacles. During this period, the safety light curtain is not able to protect access to the hazardous zone. It is therefore necessary that all operations be conducted under close supervision of experienced personnel.

**Failure to follow these instructions can result in death, serious injury, or equipment damage.**

### WARNING

#### UNINTENDED EQUIPMENT OPERATION

The OVERRIDE command must be located outside the hazardous area, in a location where the hazardous area and the entire working area concerned are clearly visible.

**Failure to follow these instructions can result in death, serious injury, or equipment damage.**

### XUSL4MB

Maximum OVERRIDE time - XUSL4MB

The OVERRIDE has a maximum duration of 15 minutes (repeatable).

The function can only restart if the button is pushed again (complying with the following conditions):

- Maximum OVERRIDE time (after n consecutive requests) = 60 min
- Maximum number of consecutive OVERRIDE requests = 30

At the release of the safety light curtain and muting sensors (when both are cleared), the OVERRIDE ends and the GUARD condition is reactivated (the safety light curtain is working properly) without additional command.

The timer and the counter are reset if one of the following conditions occurs:

- A proper sequence of Muting
- A system reset (turning it off and on)

**XUSL4MB Override with Spring Return Key (Hold-to-run Action Control)**

OVERRIDE with Spring Return Key starts with the simultaneous activation of the two OVERRIDE inputs according to the following table:

Type of override control	Pin 9	Pin 10	Operation
Hold-to-run action (spring return key)	24 Vdc	24 Vdc	Override request
	Not connected (0 Vdc)	Not connected (0 Vdc)	Override not requested

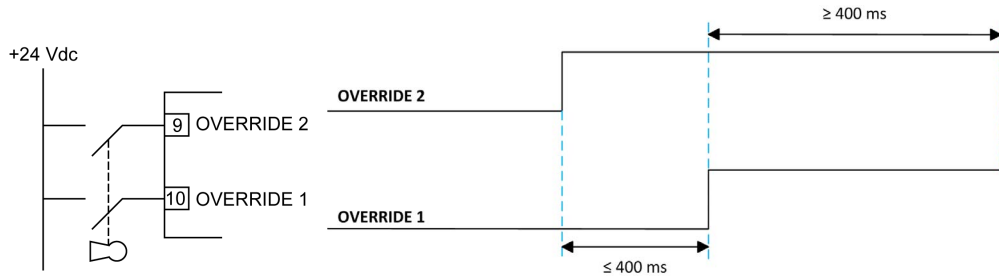

Both signals are active at 24 Vdc. The function starts only if they are activated at the same time (within a maximum delay of 400 ms) and the key is kept active for at least 400 ms.

OVERRIDE has a maximum duration of 15 minutes; it can end due to two different causes:

- At the release of the safety light curtain and muting sensors.
- When the selector is released or the 15 minutes expire, the OVERRIDE ends, bringing the OSSD outputs to OFF, turning off the lamp, and returning the display to normal. However, it is still possible to start a new OVERRIDE, releasing the selector and reactivating it.

**XUSL4MB Override with Pushbutton (Pulse Action Control)**

OVERRIDE with Pushbutton starts with the simultaneous activation of the two OVERRIDE inputs according to the following table:

Type of override control	Pin 9	Pin 10	Operation
Pulsed action (pushbutton)	24 Vdc	Not connected (0 Vdc)	Override request
	Not connected (0 Vdc)	24 Vdc	Override not requested

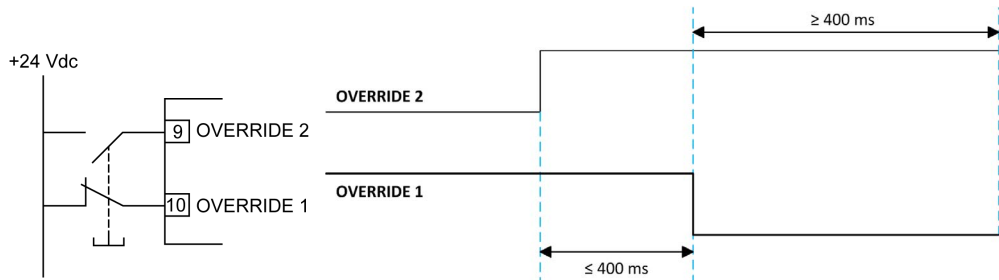

The activation of this function occurs inverting (within a time window of 400 ms) the condition of pins 9 and 10 of the receiver for at least 400 ms by using a push button with 1 NO + 1 NC contacts.

When OVERRIDE is active, the condition of pins 9 and 10 is no longer verified.

OVERRIDE has a maximum duration of 15 minutes; it can end due to two different causes:

- At the release of the safety light curtain and muting sensors.
- When the 15 minutes expire, the OVERRIDE ends, bringing the OSSD outputs to OFF, turning off the lamp, and returning the display to normal. However, it is still possible to start a new OVERRIDE, releasing the pushbutton and reactivating it.

## XUSL4MA

Thanks to the SoMute software, the operator can enable and choose the OVERRIDE mode (with spring return key or with pushbutton) and its timeout.

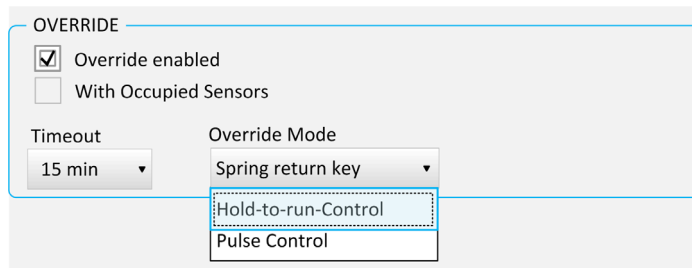

OVERRIDE

Override enabled  
 With Occupied Sensors

Timeout: 15 min

Override Mode: Spring return key

Hold-to-run-Control  
Pulse Control

**With Occupied Sensors:** when selected, the safety light curtain AND at least one muting sensor must be interrupted to activate the OVERRIDE.

**Timeout:** allows to set the time within which the Override function must end (from 5 min to 30 min)

Maximum OVERRIDE time - XUSL4MA

The function can only restart if the button is pushed again (complying with the following conditions):

- Maximum OVERRIDE time (after consecutive requests) = 4 x timeout OVERRIDE
- Maximum number of consecutive OVERRIDE requests = 30

At the release of the safety light curtain and muting sensors, the OVERRIDE ends and the GUARD condition is reactivated.

## Section 2.4 Operating States

### Operating States

#### General Information





XUSL4M transmitter and receiver are equipped with leds for real-time signaling during operation.

In addition, the receiver (XUSL4MA models) is equipped with a LED signal lamp integrated in the upper cap.

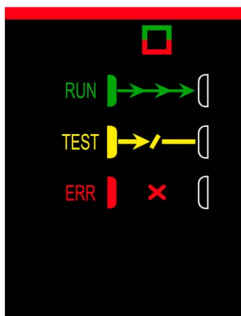
Refer to the following tables for the meaning of the LEDs.

#### Transmitter Operating States



Operating State	LED Indication	Figure	Description
Run state	Green		Normal operating state. The Run indicator is lit. The transmitter is operational.
Test state	Yellow		The indicator is lit when the Test Function ( <a href="#">see page 32</a> ) is activated.
Error state	Red flashes		This state occurs when the system is in error conditions. In this state, the two receiver safety outputs switch to the OFF state and the red transmitter indicator flashes. When the system is in error state, the guarded machine is not allowed to operate. For meaning of the red flashes, refer to Troubleshooting ( <a href="#">see page 110</a> ).
Power-on test state	Red		This state occurs during the power-on and initial test phases.



Receiver Operating States

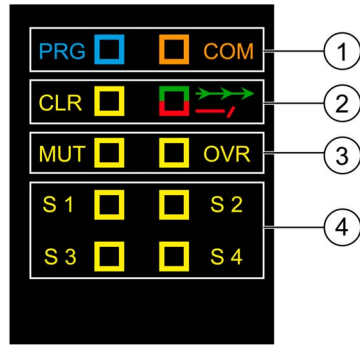

- 1 Programming functions LED
- 2 Operating states LED
- 3 Muting functions LED
- 4 Muting sensors LED



Programming functions LED:

Function	Figure	LED status	Description
Programming		Blue	Safety light curtain programmed via USB
		Orange	Communication with PC active
		Blue flashes	No safety light curtain programming
		Orange flashes	
		Blue flashes	This state occurs when a double programming (hardware and software) is detected.
		Orange flashes	
		Red flashes	





Operating states LED:

Operating state	Figure	LED status	Description
Run state		Green	Normal operating state (safety light curtain cleared). The two receiver safety outputs are in ON state. The guarded machine is allowed to operate.
Stop state		Red	This state occurs when at least one beam is interrupted (safety light curtain interrupted). The two receiver safety outputs are in OFF state. The guarded machine is not allowed to operate.
Error state		Red flashes	This state occurs when the system is in error condition. The two receiver safety outputs switch are in OFF state. The guarded machine is not allowed to operate. For more details, refer to Receiver Troubleshooting ( <a href="#">see page 111</a> ).
Start/Restart state		Yellow	This state occurs when the system is in manual Start/Restart mode (safety light curtain cleared). The two receiver safety outputs are in the OFF state. When the system is in this state, the guarded machine is not allowed to operate until the detection zone is clear of obstructions, and the start button is pressed and released.

Muting functions LED:





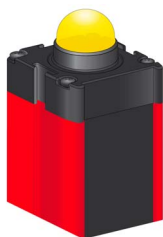

Function	Figure	LED status	Description
Muting		Yellow	This state occurs when the muting function is active. Refer to Muting Description ( <a href="#">see page 35</a> )
Override		Yellow	Override active. Refer to Override Description ( <a href="#">see page 53</a> )
		Yellow flashes	Override request. Refer to Override Description ( <a href="#">see page 53</a> )

Muting sensors LED:

Sensor	Figure	LED status	Description
Muting sensors		Yellow	Muting sensor S1 interrupted
			Muting sensor S2 interrupted
			Muting sensor S3 interrupted
			Muting sensor S4 interrupted

Receiver Integrated Lamp (XUSL4MA models)



Operating state	Muting Lamp		Description	OSSD States	Details
Start/Restart state	Yellow/Green		Safety light curtain awaiting Restart (safety light curtain cleared)	OFF	Refer to Operating state LED signals description ( <a href="#">see page 57</a> ).
Run state	Green		Normal operation (safety light curtain cleared)	ON	
Stop state	Red		Safety light curtain interrupted	OFF	
Error state	Red Flashing		Detected failure. Refer to Receiver Troubleshooting ( <a href="#">see page 111</a> )	OFF	
Muting	Yellow		Muting function is active	ON	Refer to Function LED signals description ( <a href="#">see page 57</a> ).
Override	Yellow Flashing		Override active	ON	
	Yellow/Red Flashing		Override request	OFF	

## Section 2.5 System Components

### System Components Identification

#### General Description

This figure displays the system components:

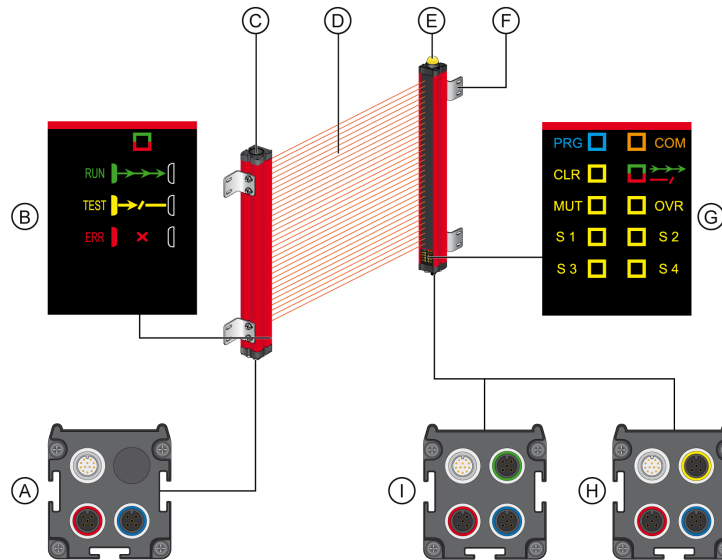

This table describes the system components:

Component	Description
A	Transmitter Connections ( <a href="#">see page 95</a> )
B	Transmitter Signals ( <a href="#">see page 56</a> )
C	Transmitter
D	Detection Zone
E	Receiver
F	Side Mounting T-slot
G	Receiver Signals ( <a href="#">see page 57</a> )
H	XUSL4MB Receiver Electrical Connections ( <a href="#">see page 97</a> )
I	XUSL4MA Receiver Electrical Connections ( <a href="#">see page 99</a> )



---

## Part II

### Preinstallation Considerations

---

#### Overview

This part provides detailed information about the safe mounting distance and additional mounting considerations.

#### What Is in This Part?

This part contains the following chapters:

Chapter	Chapter Name	Page
3	Safe Mounting Distance	63
4	Additional Mounting Considerations	71



# Chapter 3

## Safe Mounting Distance

### Overview

### NOTICE

#### UNINTENDED EQUIPMENT OPERATION

All quotations and statements from Occupational Safety and Health Administration (OSHA) and American National Standards Institute (ANSI) apply to the USA only.

**Failure to follow these instructions can result in equipment damage.**

### ⚠ WARNING

#### IMPROPER SETUP

- Install the XUSL4M safety light curtain system at the safe mounting distance calculated using the appropriate formula.
- Ensure that the XUSL4M safety light curtain system is mounted far enough away from the operation hazards to accommodate the stopping time fully.
- When using a safety interface like safety relays or controllers, the response time of the safety interface must be added to the overall system stopping time.

**Failure to follow these instructions can result in death, serious injury, or equipment damage.**

The XUSL4M safety light curtain system must be mounted at safe distance from the hazardous zone so that the machine stops before a hand or other body part reaches the hazardous zone. This distance is called the minimum safe mounting distance **S**. It is a number calculated from a formula. Before installing the XUSL4M safety light curtain, you must determine the safe mounting distance.

Regardless of the calculated distance, never mount an XUSL4M safety light curtain system closer to a point of operation hazard than specified (Table O-10) ([see page 70](#)).

This figure displays the minimum safe mounting distance (**S**) to a point of operation or hazardous zone:

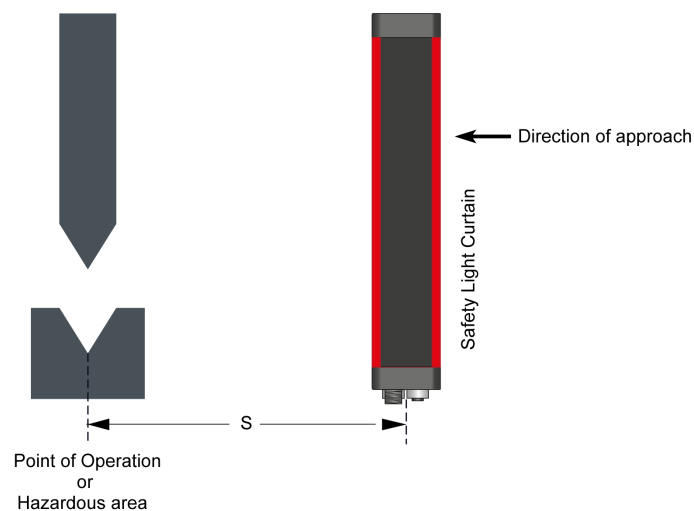

### What Is in This Chapter?

This chapter contains the following topics:

Topic	Page
European Safe Mounting Distance Formula	64
Detection Zone Approaches	65
U.S. Safe Distance Formula	69

## European Safe Mounting Distance Formula

### Introduction

The minimum safe mounting distance discussed in this section is based on European standard EN/ISO 13855. This standard applies to safety light curtains used in industrial environments.

### General Formula

The minimum safe mounting distance **S**, is calculated from the following formula:

**S = (K x T) + C**, where:

**S** = the minimum safe distance in millimeters between the hazardous zone and the detection point, line, plane, or zone.

**K** = the theoretical speed of approach of the body, or parts of the body, in millimeters per second.

**T** = the overall system stopping performance in seconds.

**T = t<sub>1</sub> + t<sub>2</sub>**, where:

**t<sub>1</sub>** = the maximum response time of the safety light curtain in seconds. This is the time it takes for the output signal switching devices to change to OFF state after the safety light curtain actuates. This value is listed on the safety light curtain labels and in the Specifications ([see page 118](#)) of this manual.

**t<sub>2</sub>** = the maximum response time of the machine in seconds. This is the time it takes for the machine to stop or remove the risk after it receives the output signal from the safety light curtain.

**C** = an additional distance in millimeters based on the resolution of the safety light curtain.

### Applying the Formula

The values of variables **K** and **C** used in the general formula vary depending on how the safety light curtain is mounted.

Three safety light curtain mounting schemes are discussed in this section. Refer to the appropriate method for your application, and use the applicable safe distance formula:

- Normal (perpendicular) approach: The direction of approach for the operator is perpendicular to the detection zone. For more information, refer to the Normal approach figure ([see page 65](#)).
- Parallel approach: The direction of approach for the operator is parallel to the detection zone. For more information, refer to the Parallel approach figure ([see page 66](#)).
- Angled approach: The direction of approach for the operator is at an angle to the detection zone. For more information, refer to the Angled approach figure ([see page 66](#)).



## Detection Zone Approaches

### Normal (Perpendicular) Approach

This figure displays the normal (perpendicular) approach to the detection zone:

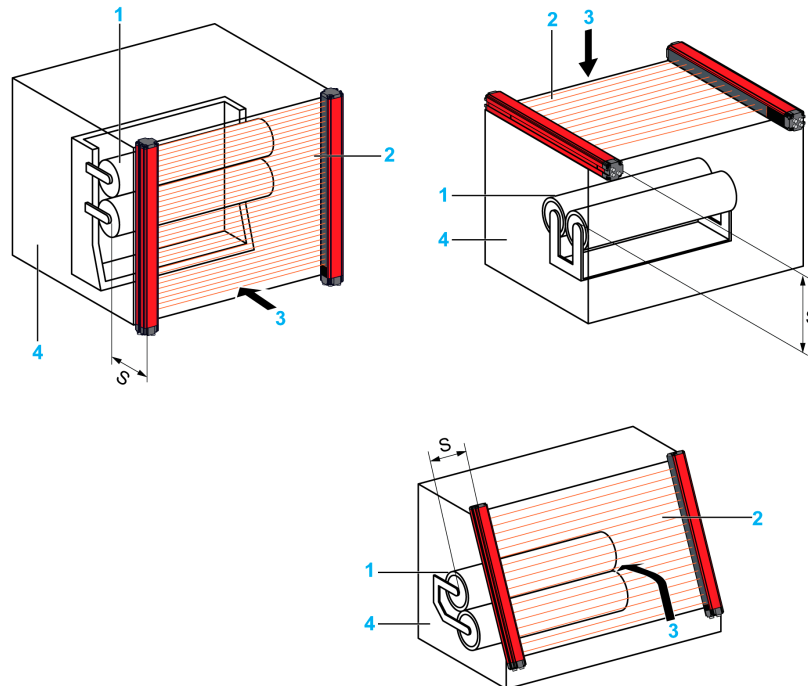

- S:** Minimum safe distance  
**1:** Hazardous zone  
**2:** Detection zone  
**3:** Direction of approach  
**4:** Fixed guard

If the direction of approach of the operator is perpendicular to the detection zone as shown in the figure, and the resolution of the system is 40 mm or less, use the following formula to calculate the safe mounting distance, **S**:

$$S = (K \times T) + C$$

**S = (2000 mm/s x T) + 8 x (R - 14 mm)**, where:

**K** = 2000 mm/s

**T** = Total response time

**C** = 8 x (R - 14 mm), but not less than 0

**R** = Resolution of the safety light curtain in millimeters.

You can calculate the safe mounting distance **S**, using this formula with values for **T** and **R** that are appropriate for the safety light curtains.

The following lists the conditions for safe mounting distance calculation:

- If the calculated value of **S** is greater than or equal to 100 mm (3.94 in.) and less than or equal to 500 mm (19.68 in.), use the calculated value for the safe mounting distance.
- If the calculated value of **S** is less than 100 mm, use 100 mm as the safe mounting distance.
- If the calculated value of **S** is greater than 500 mm (19.68 in.), recalculate **S** with an alternate value for **K** as shown in the given formula:  

$$S = (1600 \text{ mm/s} \times T) + 8 \times (R - 14 \text{ mm})$$

**Parallel Approach**

This figure displays the parallel approach to the detection zone:

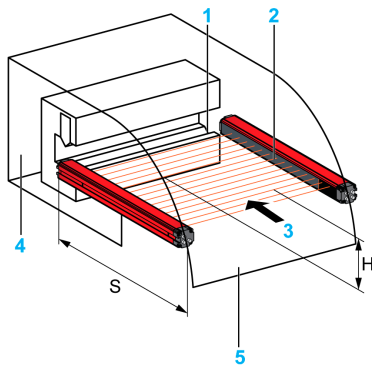

- S:** Minimum safe distance
- 1:** Hazardous zone
- 2:** Detection zone
- 3:** Direction of approach
- 4:** Fixed guard
- 5:** Beginning of the detection zone

If the direction of approach of the operator is parallel to the detection zone as shown in the figure, calculate the minimum safe mounting distance, **S**, with the following formula:

$$S = (1600 \text{ mm/s} \times T) + (1200 \text{ mm} - 0.4 \times H), \text{ where:}$$

$$K = 1600 \text{ mm/s}$$

$$C = 1200 \text{ mm} - 0.4 \times H \text{ (not less than 850 mm), where:}$$

**H** = the height of the detection zone above the reference plane (for example, the floor) in millimeters.

***NOTICE***

**UNINTENDED EQUIPMENT OPERATION**

The maximum value allowed for **H** is 1000 mm (39.37 in.). If the value of **H** exceeds 300 mm (11.81 in.), then additional protective devices must be used.

**Failure to follow these instructions can result in equipment damage.**

**Angled Approach**

This figure displays the angled approach to the detection zone:

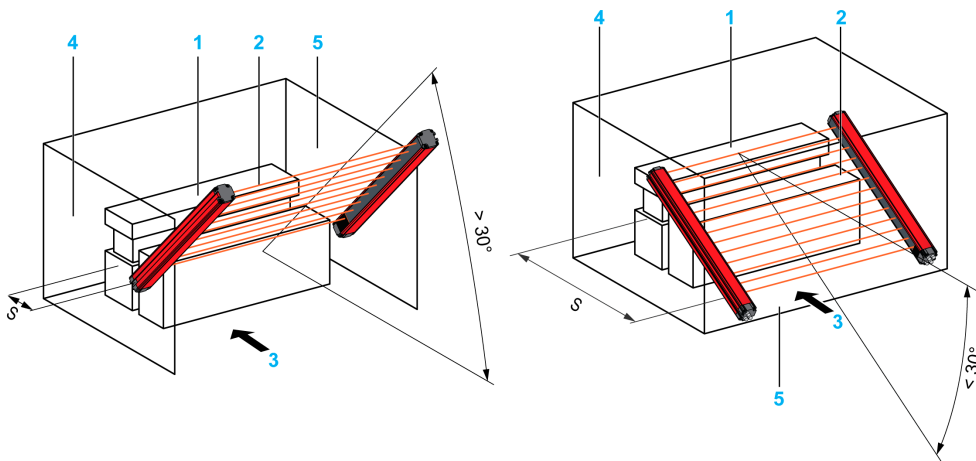

- S:** Minimum safe distance
- 1:** Hazardous zone
- 2:** Detection zone
- 3:** Direction of approach
- 4:** Fixed guard
- 5:** Beginning of the detection zone

When the direction of approach of the operator is at an angle to the detection zone as shown in the figure, the safe mounting distance formula depends on the size of the angle.

The following lists the conditions for safe mounting distance calculation at different angles:

- If the angle is greater than 30°, use the formula provided for the normal (perpendicular) approach ([see page 65](#)).
- If the angle is less than or equal to 30°, use the formula provided for the parallel approach ([see page 66](#)).

### Calculation Example

#### Normal (Perpendicular) Approach

In this example, the machine has a stopping time of 60 ms ( $t_2$ ). It is fitted with a safety light curtain having a resolution of 30 mm (**R**) and a response time of 30 ms ( $t_1$ ). The safety light curtain is mounted in such a way that the direction of approach of the operator is perpendicular to the detection zone as shown in the figure for normal approach ([see page 65](#)).

Use the formula for normal (perpendicular) approach with a resolution of less than 40 mm to calculate the minimum safe mounting distance, **S**:

The formula is **S = (2000 mm/s x T) + 8 x (R – 14 mm)**, where:

**T** = Total response time ( $t_1 + t_2$ ) = (60 + 30) ms = 90 ms, or 0.09 s

**R** = 30 mm

Calculate as follows:

$$S = (2000 \text{ mm/s} \times 0.09 \text{ s}) + 8 \times (30 - 14) \text{ mm}$$

$$S = (180 + 128) \text{ mm}$$

$$S = 308 \text{ mm}$$

### Multiple Beam Models

The minimum safe mounting distance is calculated by the formula:

$$S = (1600 \text{ mm/s} \times T) + 850 \text{ mm}$$
 where:

**T** = Total response time

Perimeter access systems consist of multiple separate beams. These types of devices are designed for body detection and not torso detection.

This table shows the practical positions for a 2, 3, and 4 beams system:

Positions for Multiple Beam Systems	
No. of beams	Height of beams above reference plane (for example, the floor)
4	300, 600, 900, 1200 mm
3	300, 700, 1100 mm
2	400, 900 mm <sup>(1)</sup>
1	For the lowest beam, 400 mm can only be used when the risk assessment allows it.

This figure displays the example of beam positions with 3 beams model:

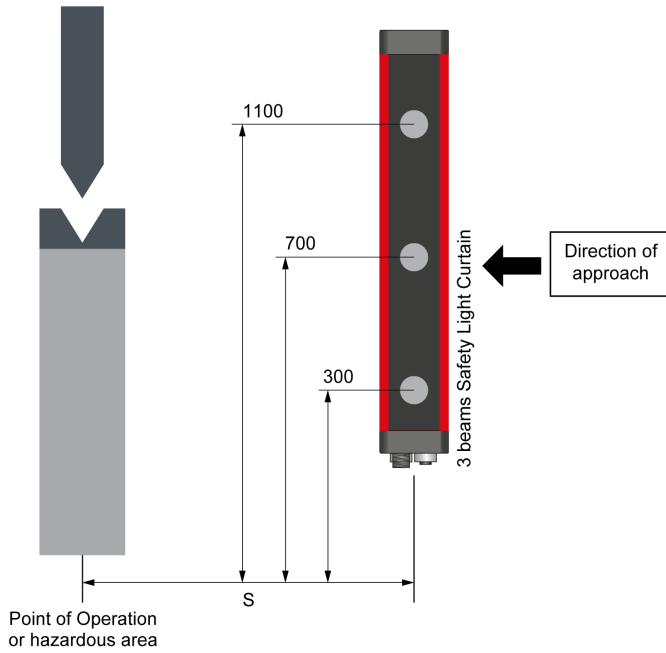

**⚠ WARNING**

**IMPROPER SETUP**

Multiple beam models are designed for body detection. Do not use multiple beam models for torso, arm, or leg detection.

For the lowest beam, 400 mm can only be used when the risk assessment allows it.

Consider the following possible scenarios during the risk assessment:

- Crawling below the lowest beam.
- Reaching over the top beam.
- Reaching through two of the beams.
- Bodily access - intrusion between two beams.

**Failure to follow these instructions can result in death, serious injury, or equipment damage.**

**Factors Affecting the Safe Distance Formula**

When safety light curtains are used to initiate the machine, their resolution must be 30 mm or less according to EN/ISO 13855 standard (this requirement may vary with other standards).

In machine initiation applications, use the formula given for normal (perpendicular) approach with a resolution of less than 40 mm to calculate the minimum safe mounting distance (**S**). However, if the calculated value of **S** is less than 150 mm, use 150 mm as the safe mounting distance.

**⚠ WARNING**

**IMPROPER SETUP**

If the calculated distance **S** is such that an operator can stand between the safety light curtain and the hazardous zone, additional protection is required, such as a physical guard or barrier comprising several parts. Consult all applicable standards.

**Failure to follow these instructions can result in death, serious injury, or equipment damage.**

## U.S. Safe Distance Formula

### General Description

There are two different formulas available to calculate the safe mounting distance for safety light curtains that are mounted vertically. They are as follows:

- One formula described in OSHA 1910.217, applies to the guarding of mechanical power presses, but should serve as a guide for other machine applications.
- The American National Standards Institute (ANSI) standard uses another formula which includes more factors when calculating the safe mounting distance.

The basic formulas for calculating safe mounting distances for safety light curtains mounted vertically are in this section. These formulas apply to all safety light curtains.

### U.S. Safe Distance Formula ANSI B11.1

The ANSI B11.1 formula is described here.

$D_s = K \times (T_s + T_c + T_r + T_{bm}) + D_{pf}$ , where:

$D_s$  = The minimum safe distance between the safety light curtain sensing area and the nearest point of potential operation hazard.

$K$  = A hand-speed constant of 63 inches per second. This is the minimum value accepted by ANSI standards. ANSI recognizes that this constant may not be optimal, and thus you must consider all factors before deciding on the value of  $K$  for use in the formula.

$T_s$  = The stopping time of the machine (i.e, a press), as measured from the final control device.  $T_s$  is measured at the maximum velocity.

$T_c$  = The time it takes the control circuit to activate the braking system.

**NOTE:**  $T_s$  and  $T_c$  are measured together by a stop time measurement device.

$T_r = t_1$  = The response time of the XUSL4M safety light curtain in milliseconds. For more information, refer to Specifications ([see page 118](#)).

$T_{bm}$  = The additional time that the brake monitor allows to compensate for wear and variations in the stopping time (brake monitors stops the machine when the stop time of the machinery exceeds a preset limit).

## NOTICE

### UNINTENDED EQUIPMENT OPERATION

If brake monitoring is not installed on the machine, a factor must be added to the measured stop time to include brake wear. Approximately, the brake monitoring allows 20% to 25% additional stop time. To determine the actual value, contact the machine manufacturer.

**Failure to follow these instructions can result in equipment damage.**

**Dpf** (Depth penetration factor) = The maximum travel toward the hazard within the detection zone that may occur before a stop is signaled. Depth penetration factors vary depending on the safety light curtain model and the application as given below:

- Dpf is 0.9 m (36 in.) for an application that allows only an arm of a person to reach through the detection zone (typically a model with three or more beams).
- Dpf is 1.2 m (48 in.) for an application that allows a person to bend over the detection zone and reach through it towards the hazard (typically a two-beam model).

This figure describes the Depth Penetration Factor (Dpf) calculation:

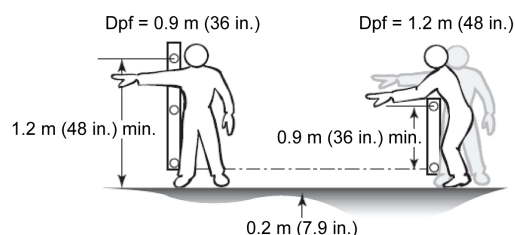

For 14 mm (0.551 inches) and 30 mm (1.181 inches) resolutions, the depth penetration factor is determined using the Depth Penetration Factor Chart from ANSI B11.1 (shown in figure below). Alternately, the following ANSI formula can be used:

**Dpf = 3.4 x (R - 0.276)**, where

R = Resolution in inches

**Depth Penetration Factor Vs Resolution**

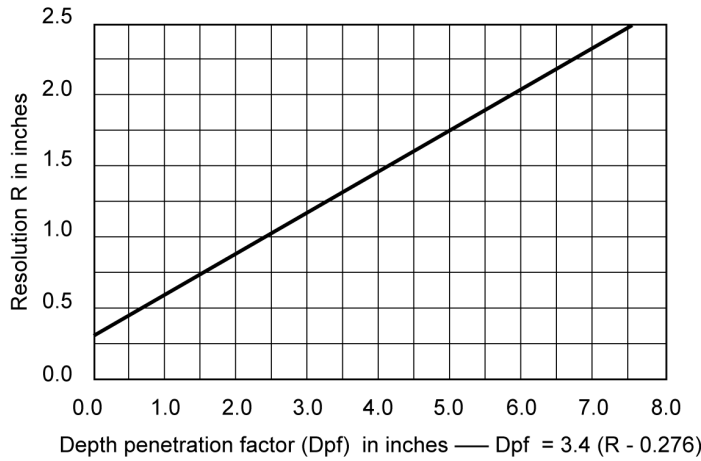

**U.S. Safe Distance Formula (OSHA CFR 1910.217)**

The OSHA formula is described here.

**D<sub>s</sub> = 63 in. per second x T<sub>s</sub>**, where:

D<sub>s</sub> = Minimum safe mounting distance (inches).

63 in. per second = hand speed constant

T<sub>s</sub> = Stop time of the machine (that is, a press), as measured from the final control element. It is measured to determine worst case time and maximum velocity of the press, usually at 90° of press rotation on the downstroke.

In addition to the formula above, it is recommended to follow OSHA 1910.217 Table O-10 also. This table shows the maximum width of openings allowed for a guard based on the distance from the safety light curtain to the point of operation hazard. The maximum width of the opening shown in this table corresponds to the resolution of the safety light curtain.

**OSHA 1910.217 Table O-10**

Distance from the safety light curtain to the Point of Operation Hazard (inches)	Maximum Width of Opening - Resolution (inches)
0.5...1.5	0.25
1.5...2.5	0.375
2.5...3.5	0.5
3.5...5.5	0.625
5.5...6.5	0.75
6.5...7.5	0.875
7.5...12.5	1.25
12.5...15.5	1.5
15.5...17.5	1.875
17.5...31.5	2.125

***NOTICE***

**UNINTENDED EQUIPMENT OPERATION**

If the guarded machine is not equipped with downtime monitoring, a percentage increase factor must be applied to the stop time of the machine to allow for braking system wear. Contact your machine manufacturer for information.

**Failure to follow these instructions can result in equipment damage.**

---

# Chapter 4

## Additional Mounting Considerations

---

### Overview

This chapter describes additional mounting considerations.

 <b>DANGER</b>
<b>HAZARD OF ELECTRIC SHOCK, EXPLOSION, OR ARC FLASH</b>
Never remove the end caps of the safety light curtain system.
<b>Failure to follow these instructions will result in death or serious injury.</b>

 <b>WARNING</b>
<b>IMPROPER SETUP</b>
<ul style="list-style-type: none"><li>• Read the information in this section completely before starting the installation procedures (<a href="#">see page 81</a>).</li><li>• An XUSL4M safety light curtain system must be installed, checked, and maintained by qualified personnel as defined in the Meeting Full Compliance (<a href="#">see page 11</a>).</li><li>• You must be familiar with the installation requirements, safe mounting distance, system controls, and features before using the XUSL4M safety light curtain system.</li></ul>
<b>Failure to follow these instructions can result in death, serious injury, or equipment damage.</b>

### What Is in This Chapter?

This chapter contains the following topics:

Topic	Page
Reflective Surface Interference	<a href="#">72</a>
Test Rod Procedure	<a href="#">74</a>
Additional Guarding	<a href="#">75</a>
Multiple Systems	<a href="#">76</a>

## Reflective Surface Interference

### General Description

A reflective surface such as a machine part, mechanical guard, or workpiece near the detection zone can deflect the optical beam and prevent an obstruction in the protected zone from being detected.

### Example of Reflective Surface Interference

In this figure, the obstruction is not detected due to the reflection. The reflective object or surface is inside the beam angle:

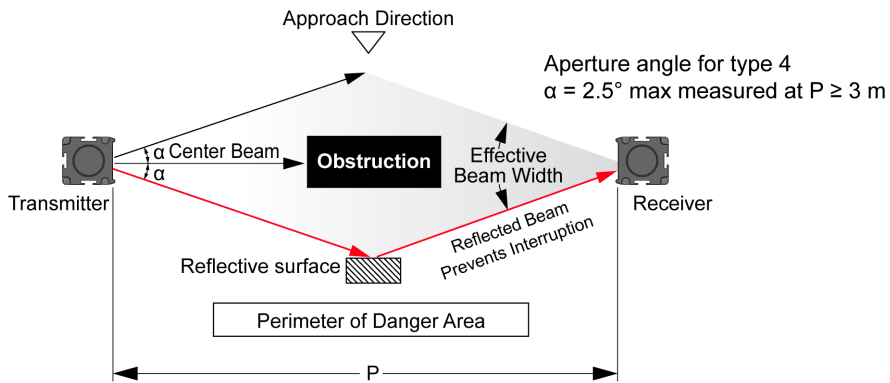

<b>⚠ WARNING</b>
<b>UNINTENDED EQUIPMENT OPERATION</b>
Presence of a reflective surface can lead to an undetected protected zone interruption. Read the information in this section completely before starting the installation procedures.
<b>Failure to follow these instructions can result in death, serious injury, or equipment damage.</b>

### Minimum Distance Between Reflective Surface and Detection Zone

To prevent reflective surface interference, maintain a minimum distance (**D**) between the reflective object and the center line of the XUSL4M detection zone as shown in the example below.

In this figure, if the reflective object is placed at a distance greater than **D**, the obstruction is clearly detected:

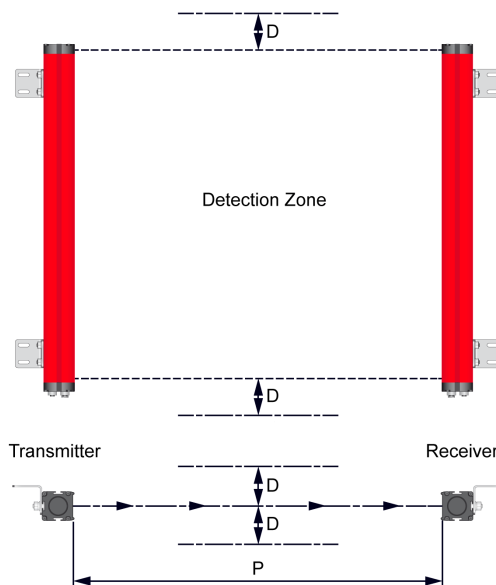



**Minimum Distance (D) from a Reflective Surface as a Function of Operating Range**

The minimum distance that must be maintained between the reflective object and the center line of the detection zone as a function of operating range of the safety light curtain is displayed in this figure:

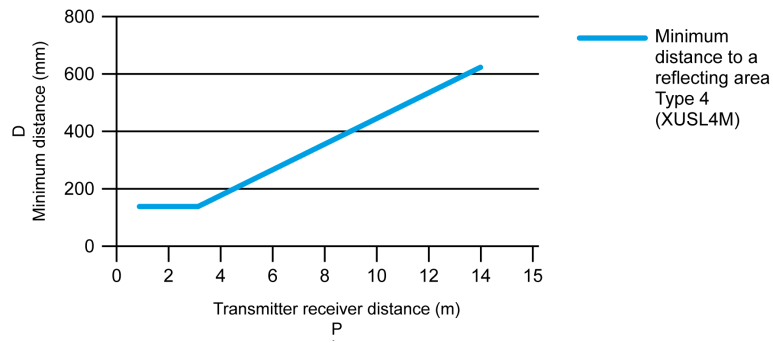

Use the Test Rod Procedure (*see page 74*) to detect any reflective surface interference.

This table describes the minimum distance to a reflecting area for different transmitter receiver distance:

Transmitter Receiver Distance P (m)	Minimum Distance to a Reflecting Area Type 4 (XUSL4M) D (mm)
1	131
2	131
3	131
4	175
6	262
8	349
10	437
12	524
14	611

To calculate the minimum distance to a reflecting area, use the following conditions:

**Type 4 (XUSL4M)**

If  $P \leq 3$  m, then  $D = 131$  mm

If  $P > 3$  m, then  $D$  (mm) =  $\tan(2.5^\circ) \times 1000 \times P$  [m] =  $43.66 \times P$  [m]

It is required to use a test rod to control that the safety light curtain is not bypassed by reflective surfaces. The test rod diameter must be equal to the resolution.

## Test Rod Procedure

### General Description

The test is to be performed in accordance to the figure below by moving the test rod slowly along the indicated path to interrupt every beam one after the other:

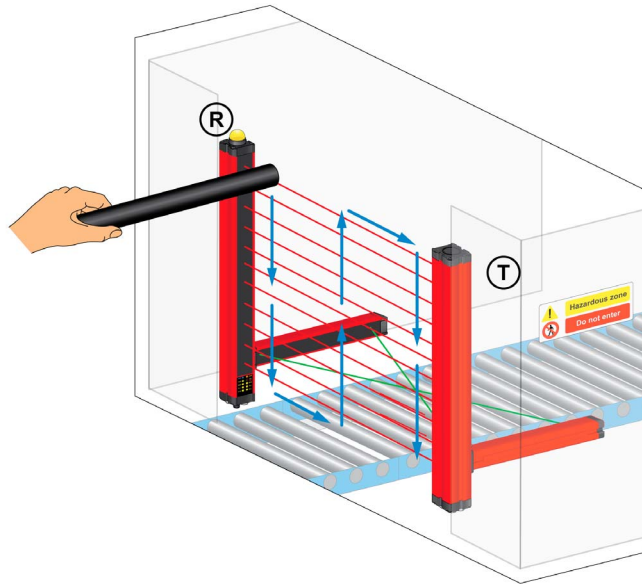

Before starting the test, you must light the green LED on the receiver. During the test, the Red LED must remain ON (lit) and the Green LED must stay OFF on the receiver. For multiple light beam systems (2,3, or 4 beams), use an opaque object to interrupt the beams one after the other by starting at the center and then close to the transmitter and receiver.

For 30 mm and 40 mm resolution models, the test rod diameter must be equal to the resolution.

### **⚠ WARNING**

#### **UNINTENDED EQUIPMENT OPERATION**

Check the correct operation of the safety light curtain at power-on phases and before each shift. A proper test object must be used to carry out this test. Suitable test rods for 30 mm and 40 mm resolution are available as accessories ([see page 134](#)).

**Failure to follow these instructions can result in death, serious injury, or equipment damage.**

**NOTE:** A periodic cleaning of the front face protection surfaces (polycarbonate optical window) of the devices is recommended. Cleaning must be carried out with a soft damp cloth only. In dusty environments, after cleaning the front face, it is advisable to spray it with an anti-static product

### **⚠ WARNING**

#### **UNINTENDED EQUIPMENT OPERATION**

- Do not use abrasive, corrosive, solvents, or alcohol that may damage the polycarbonate front surfaces.
- Do not use wiped or wool cloth to avoid electrostatically loading the polycarbonate front surfaces.

**Failure to follow these instructions can result in death, serious injury, or equipment damage.**

Even a very fine scratch on polycarbonate front surfaces can increase the width of the beam of the safety light curtain, thus compromising the effectiveness of detection in the presence of eventual reflective lateral surfaces. It is therefore required to pay particular attention during the cleaning steps of the safety curtain front surface, particularly in environments where abrasive powders are present (for example cement plants, and so on).

## Additional Guarding

### General Description

Areas of hazardous zone that are not guarded by the XUSL4M safety light curtain system must be protected by another suitable means. For example, by a fixed barrier guard or an interlocked guard.

### Additional Guarding

This figure displays additional guarding such as a fixed barrier guard and an interlocked guard:

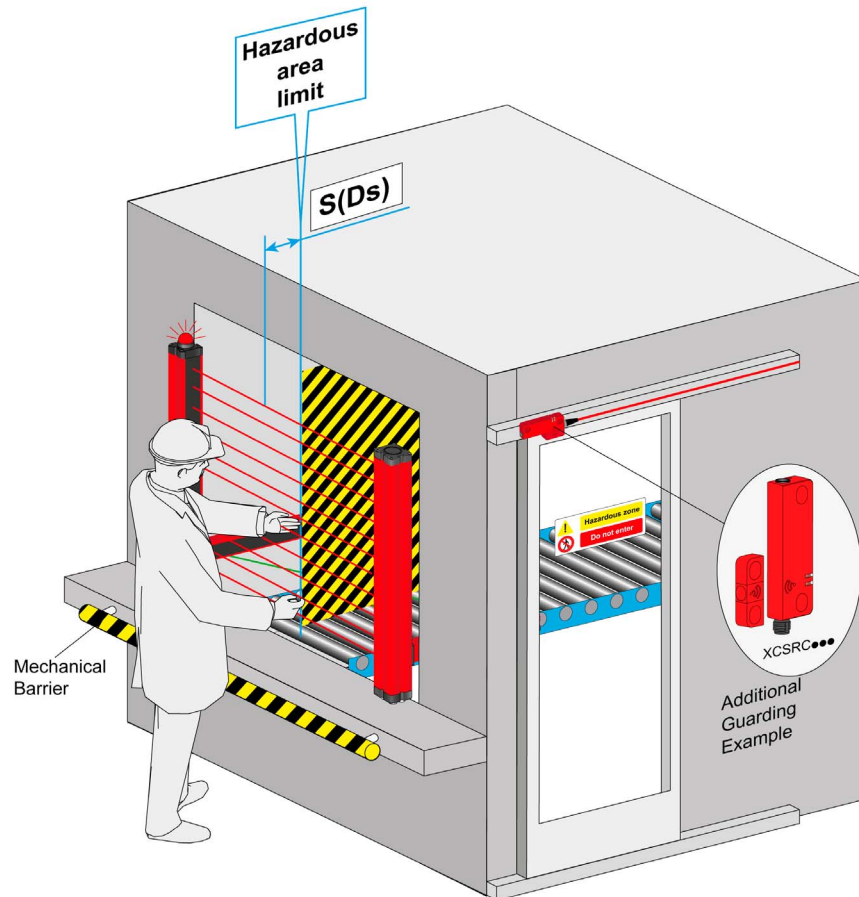

Additional safeguard shall be necessary to prevent access to the hazardous zone from any direction not protected by the safety light curtain. For more details, refer to Positioning the Crossing Point of the Two Muting Sensors ([see page 44](#)).

## Multiple Systems

### General Description

When two or more safety light curtain systems are mounted nearby, and in alignment with each other, mount the transmitters and receivers back-to-back, or stack them to prevent one safety light curtain from interfering with another. This precaution is not necessary between the segments of a Master/Slave system.

### Multiple Safety Light Curtain Installation Configurations

Configuration	Description	Figure
1	This arrangement is subject to interference between the two safety light curtains ( <b>Not recommended</b> ).	
2	The receivers are mounted back-to-back ( <b>Recommended</b> ).	

Configuration	Description	Figure
3	The safety light curtains are stacked, with the transmitters facing in opposite directions ( <b>Recommended</b> ).	
4	The safety light curtains are separated by an opaque object, which interrupt the beams ( <b>Recommended</b> ).	

## ***NOTICE***

### **UNINTENDED EQUIPMENT OPERATION**

When it is possible, the selection of low range can be an efficient way to limit the interferences due to close mountings. For more details, refer to Transmitter Connections ([see page 95](#)).

**Failure to follow these instructions can result in equipment damage.**



---

# Part III

## Installation, Wiring, and Startup

---

### Overview

This section provides information about installation, wiring, and startup.

### What Is in This Part?

This part contains the following chapters:

Chapter	Chapter Name	Page
5	Installation	81
6	Wiring	93
7	Start Up	105





---

# Chapter 5

## Installation

---

### Overview

This chapter describes the installation of the XUSL4M safety light curtain.

### What Is in This Chapter?

This chapter contains the following topics:

Topic	Page
Parts List	82
Mounting the Safety Light Curtain	83
Mounting the Safety Light Curtain with Single Beam Pre-Built Arms	85
Mounting the Safety Light Curtain with Multibeam Pre-Built Arms	87
Mounting the Safety Light Curtain with Individual Muting Sensors	90

## Parts List

### Parts

This figure displays the different parts of the XUSL4M safety light curtain system:

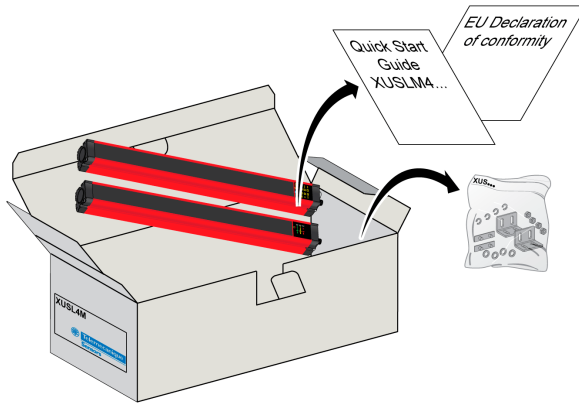

Content of the package:

- XUSL4M transmitter and receiver
- Quick Installation Guide
- Mounting accessories bag and sealing caps for unused connectors
- EU Declaration of Conformity

## Mounting the Safety Light Curtain

### Mounting

### NOTICE

#### UNINTENDED EQUIPMENT OPERATION

Before mounting the safety light curtain, refer to Safe Mounting Distance ([see page 63](#)).

**Failure to follow these instructions can result in equipment damage.**

This figure describes the mounting of the safety light curtain:

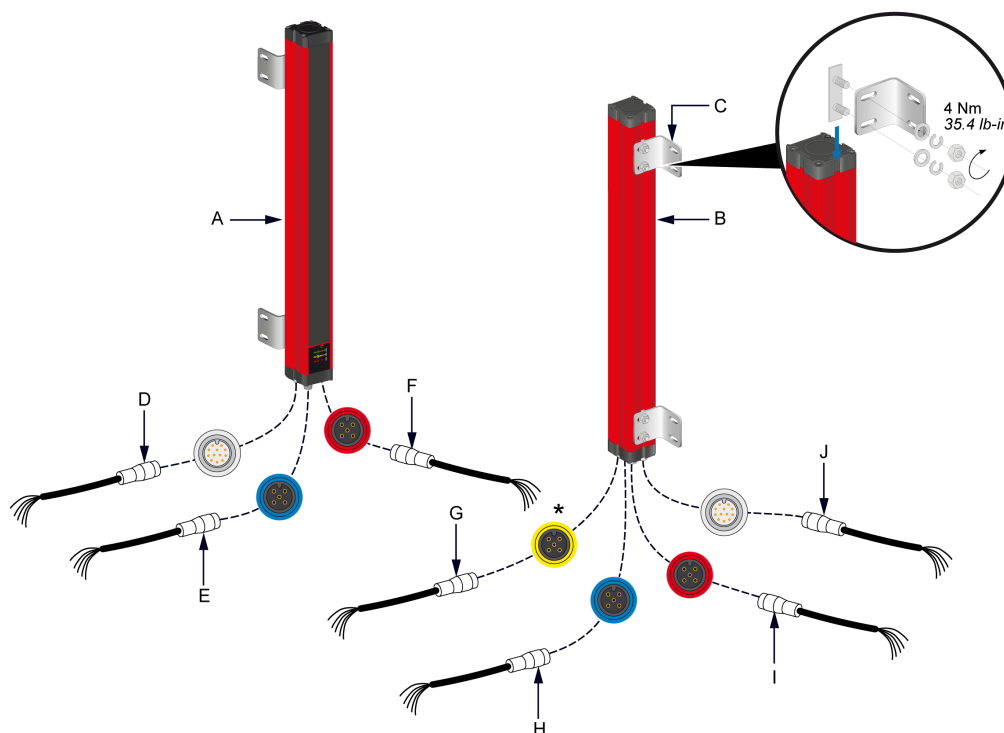

\*: Yellow (XUSL4MB) or Green (XUSL4MA)

Follow the given procedure to mount the safety light curtain:

- Using the provided mounting kit (C), install the mounting brackets (C) on the groove located in the back of the receiver (B) and transmitter (A). Other special brackets are also available as accessories, refer to Accessories ([see page 129](#)).
- Connect the main cable (J) to the receiver. For more information, refer to Wiring ([see page 95](#)).
- Connect the main cable (D) to the transmitter. For more information, refer to Wiring ([see page 95](#)).
- Connect the muting lamp (and USB for XUSL4MA) cable (G) to the receiver and the transmitter. For more information, refer to Wiring ([see page 93](#)).
- Connect the muting sensors cables (E, F, H, and I) to the receiver and the transmitter. For more information, refer to Wiring ([see page 93](#)).
- Observing the safe mounting distance, mount the receiver and the transmitter on the machine in the same plane and at equal height. For information about alignment and mounting considerations, refer to Aligning the Transmitter and Receiver ([see page 105](#)).
- Wire the safety light curtain as illustrated in Wiring ([see page 93](#)).

### NOTICE

#### UNINTENDED EQUIPMENT OPERATION

- Special brackets allowing a positioning with more mounting flexibility are also available as accessories (curved brackets).

For more information about the given accessories, refer to Accessories ([see page 129](#)).

**Failure to follow these instructions can result in equipment damage.**

### Muting Arms

Follow the given procedure to mount the muting arms:

- Install the muting arms in the groove located on each side of the receiver (B) and transmitter (A).

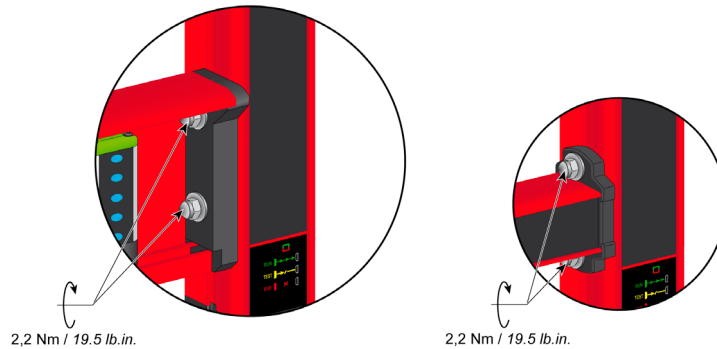

Muting arms configurations are displayed below.

- Connect the cables to the transmitter and the receiver according to the color code on the cables.

### Concerning 2 Sensors Muting Types

- When using XUSZASL2• integrated muting arms, the single output connector must be connected to the BLUE connector.
- When using XUSZAML2• or XUSZA•T2X• integrated muting arms, SENSOR 1 connector has to be wired on Sensor1 input (blue connector) and sensor 2 connector must be connected to the RED connector (sensor 3 input). Sensor 1 and sensor 2 can also be both connected to the BLUE connector through XZCRSR (for receiver) and XZCRSE (for transmitter) splitters.
- When using T2X, L2P or L2X muting types with two separate muting sensors (with 2 separate connectors):
  - Sensor 1 connector has to be wired on Sensor 1 input (Blue connector) and Sensor 2 connector must be connected to the Red connector (Sensor 3 input).
  - Sensor 1 and Sensor 2 can also be both connected to the Blue connector through XZCRSR (for receiver) and XZCRSE (for transmitter) splitters.
- In hardware configuration, the XUSL4M detects automatically the position of the connectors at the first switching of sensor 2 after power-up.
- In software configuration (XUSL4MA only), the physical position of the connectors must be set in accordance with SoMute software:

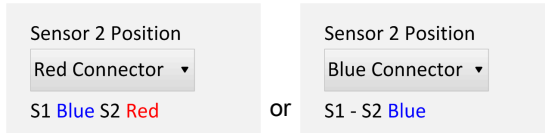

## Mounting the Safety Light Curtain with Single Beam Pre-Built Arms

### Mounting

Follow the procedure and specifications in Mounting the Safety Light Curtain chapter ([see page 83](#)).

**NOTE:** When the conveyor speed exceeds 25 m/min, it must be considered as “high-speed conveyor”.

### L2X Configuration

XUSZASL2XT for L2X configuration with 2 crossed Transmitter/Receiver single beam:

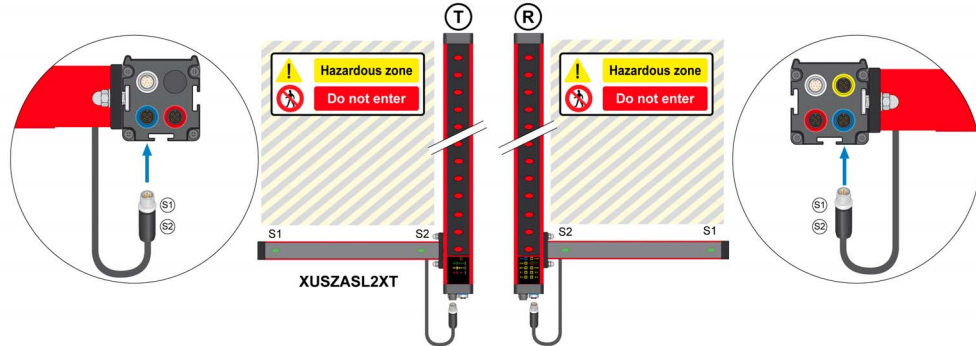

### T2X Configuration

XUSZAST2XT for T2X configuration with 2 crossed Transmitter/Receiver single beam:

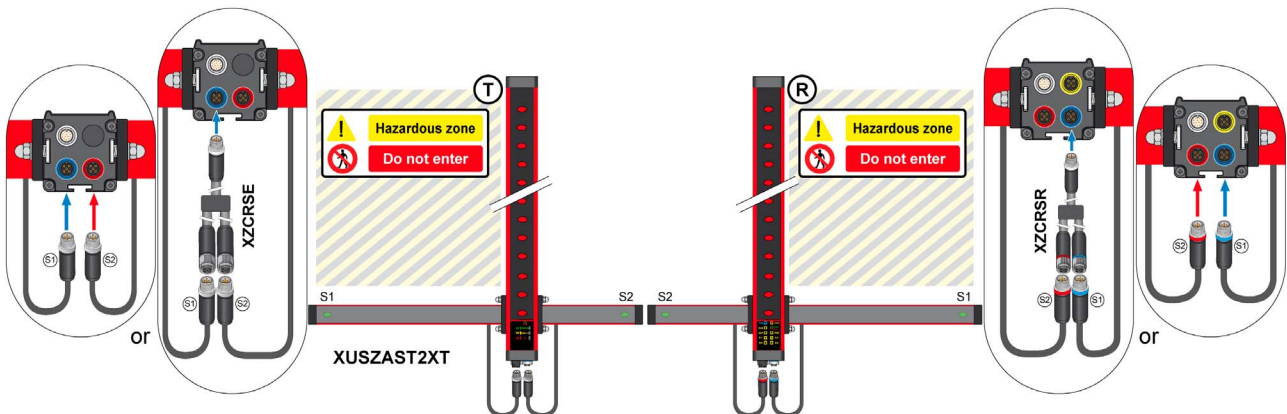

### L2P Configuration

XUSZASL2PP / XUSZASL2PPT (for detection of transparent objects) / XUSZASL2PPS (for high-speed conveyors) for L2P configuration with two parallel single beam with reflector:

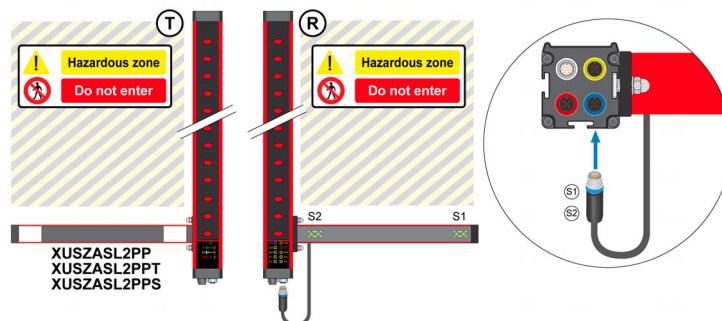

### L4P Configuration

XUSZAST4PP / XUSZAST4PPT (for detection of transparent objects) / XUSZAST4PPS (for high-speed conveyors) for T4P configuration with four parallel single beam with reflectors:

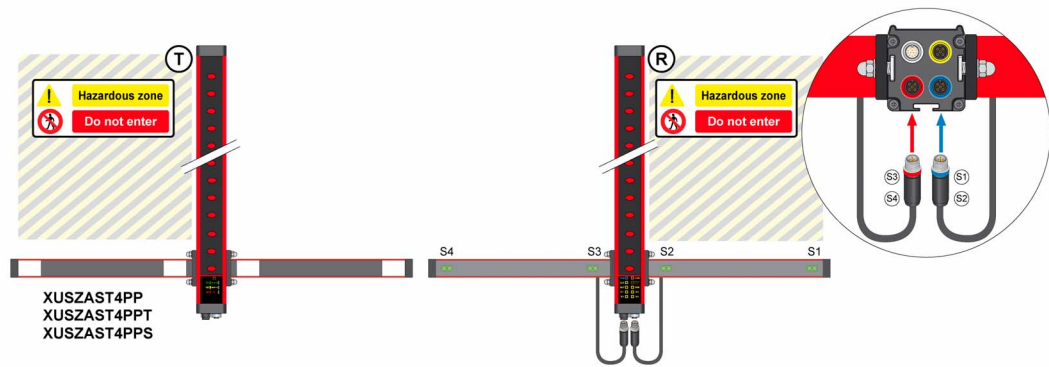

## Mounting the Safety Light Curtain with Multibeam Pre-Built Arms

### Mounting

Follow the procedure and specifications in Mounting the Safety Light Curtain chapter ([see page 83](#)).

**NOTE:** When the conveyor speed exceeds 25 m/min, it must be considered as “high-speed conveyor”.

### Multibeam Pre-Built Arms

## NOTICE

### UNINTENDED EQUIPMENT OPERATION

Multibeam (five beams) muting sensors are suitable for the detection of unconventional shape objects (for example objects with possible detection holes like piles of pallets).

**Failure to follow these instructions can result in equipment damage.**

### NOTE:

To prevent any interference between multiple beams muting sensors, the pre-built muting arms XUSZAM\* are equipped with sensors having different coding:

- XUSZPM5AXPL09: Coding "A"
- XUSZPM5BXPL09: Coding "B"

These multibeam photocells can also be ordered separately as individual muting sensors.

### L2X Configuration

XUSZAML2XP/ XUSZAML2PTS (for high-speed conveyors) for L2X configuration with 2 crossed or parallel adjustable XUSZPM5BXPL09 and XUSZPM5AXPL09 Transmitter/Receiver five beams:

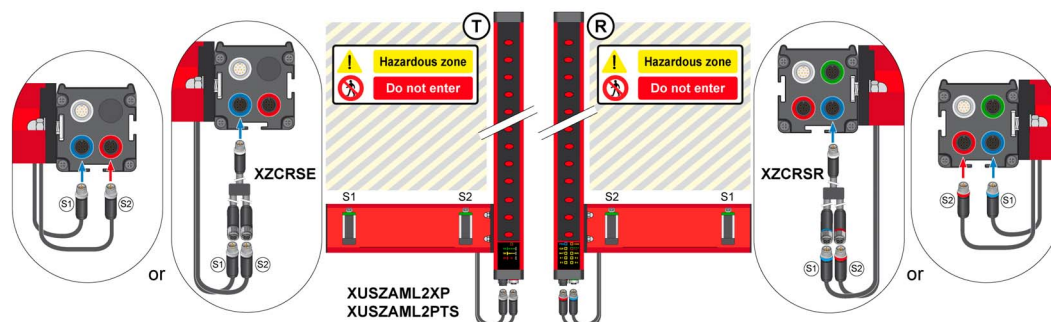

**NOTE:** XUSZAML2PTS only for parallel beams muting type

**T2X Configuration**

XUSZAMT2XT for T2X configuration with 2 crossed adjustable XUSZPM5BXPL09 and XUSZPM5AXPL09 Transmitter/Receiver five beams:

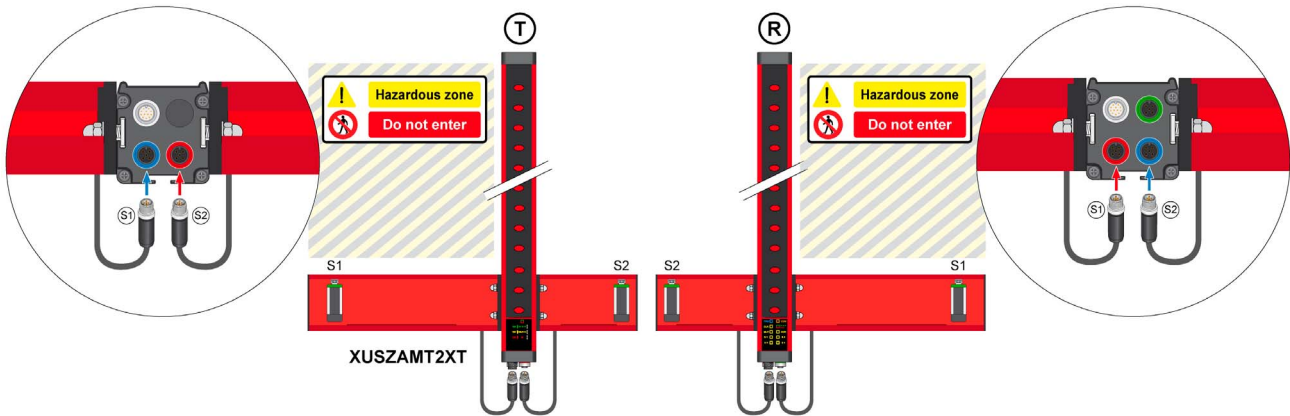

**Concerning 2 Sensors Muting Types**

- When using XUSZASL2• integrated muting arms, the single output connector must be connected to the BLUE connector.
- When using XUSZAML2• or XUSZA•T2X• integrated muting arms, SENSOR 1 connector has to be wired on Sensor1 input (blue connector) and sensor 2 connector must be connected to the RED connector (sensor 3 input). Sensor 1 and sensor 2 can also be both connected to the BLUE connector through XZCRSR (for receiver) and XZCRSE (for transmitter) splitters.
- When using T2X, L2P or L2X muting types with two separate muting sensors (with 2 separate connectors):
  - Sensor 1 connector has to be wired on Sensor 1 input (Blue connector) and Sensor 2 connector must be connected to the Red connector (Sensor 3 input).
  - Sensor 1 and Sensor 2 can also be both connected to the Blue connector through XZCRSR (for receiver) and XZCRSE (for transmitter) splitters.
- In hardware configuration, the XUSL4M detects automatically the position of the connectors at the first switching of sensor 2 after power-up.
- In software configuration (XUSL4MA only), the physical position of the connectors must be set in accordance with SoMute software:

Sensor 2 Position Red Connector ▾ S1 Blue S2 Red	OR	Sensor 2 Position Blue Connector ▾ S1 - S2 Blue
--	----	---



T4P Configuration

XUSZAMT4PT / XUSZAMT4PTS (for high-speed conveyors) for T4P configuration with 4 parallel adjustable XUSZPM5BXPL09 and XUSZPM5AXPL09 Transmitter/Receiver five beams:

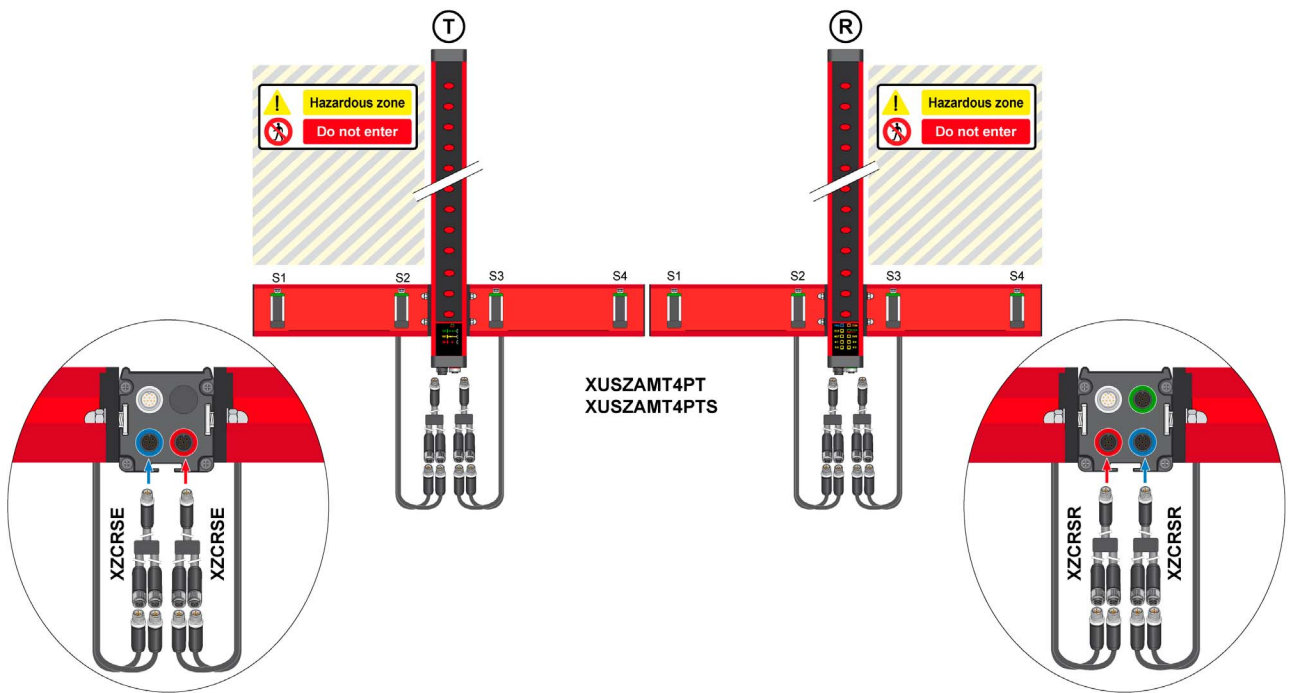

## Mounting the Safety Light Curtain with Individual Muting Sensors

### Mounting

Follow the procedure and specifications in Mounting the Safety Light Curtain chapter ([see page 83](#)).

### L2X / L2P Configuration

L2X / L2P configuration with 2 Transmitter/Receiver single beam:

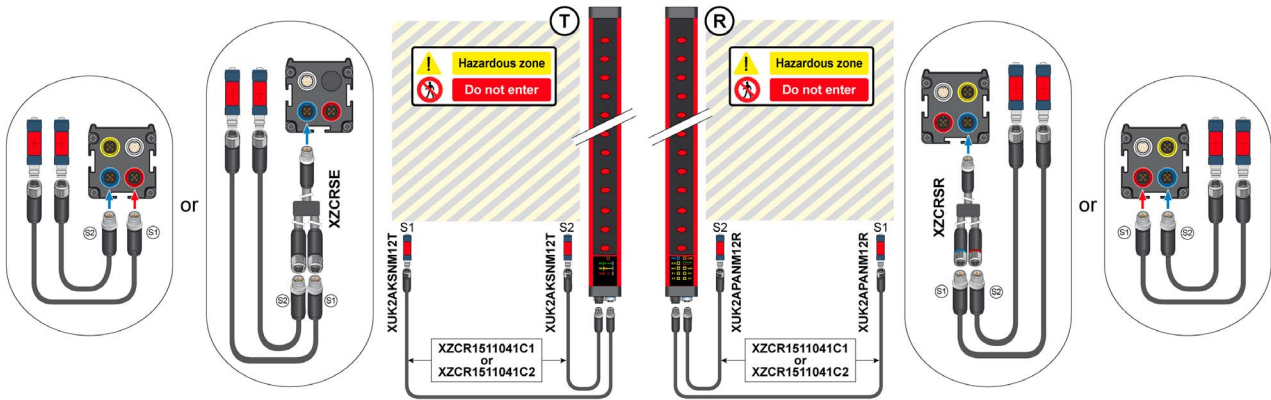

Muting sensors:

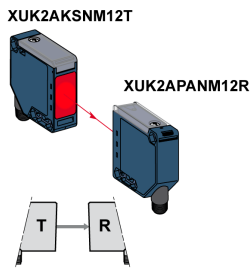

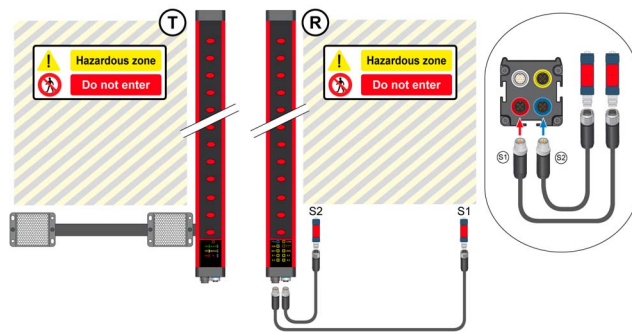

### L2P Configuration

L2P configuration with two parallel single beam with reflector:

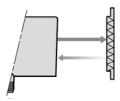
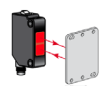

Muting sensors

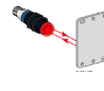
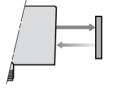
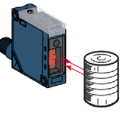
Mode	Cells references	Connection to XUSL4M through splitters cables and splitters references
	XUM9APSBM8 	2 x XZCR1509040H1/2 + 1 XZCRSR
	XUBTAPSNM12 	2 x XZCR1511041C1/2 + 1 XZCRSR
	XUK8AKSNM12 	2 x XZCR1511041C1/2 + 1 XZCRSR

T2X Configuration

T2X configuration with two Transmitter/Receiver single beam:

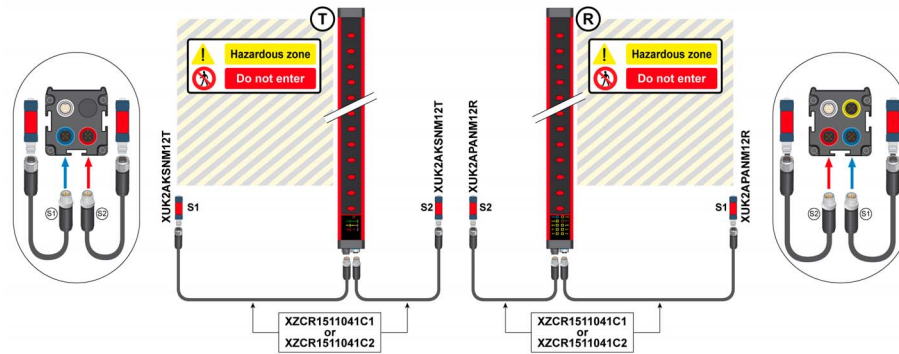

T4P Configuration

T4P configuration with four Transmitter/Receiver single beam:

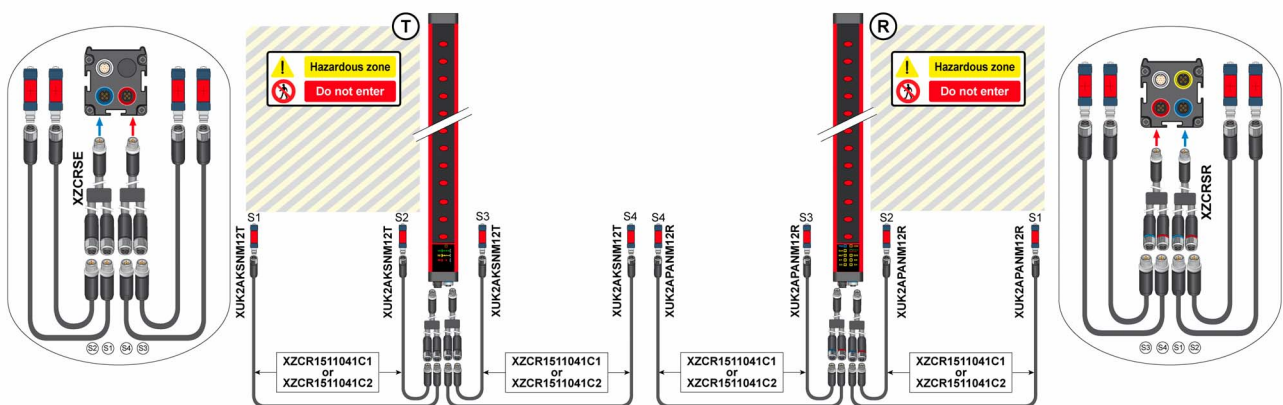

Muting sensors:

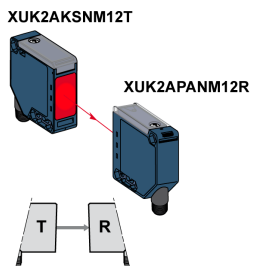

T4P configuration with four parallel single beam with reflector:

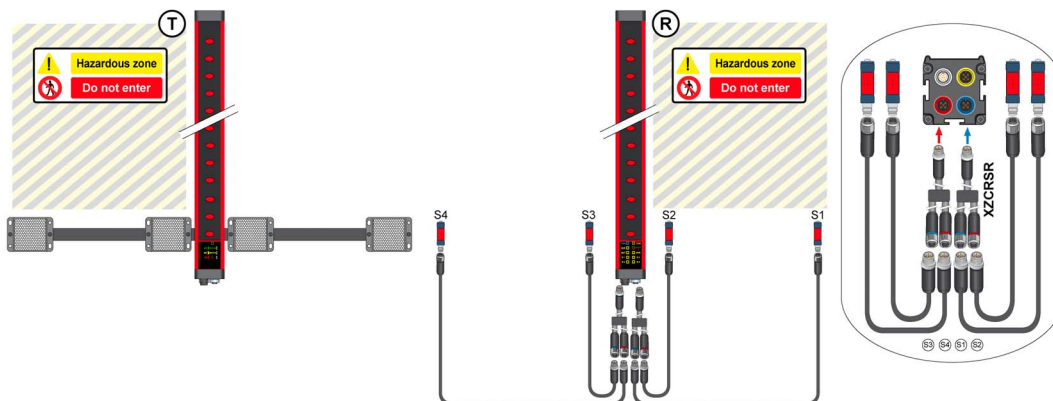

Muting sensors

Mode	Cells references	Connection to XUSL4M through splitters cables and splitters references
	<p>XUM9APSBM8</p>	2 x XZCR1509040H1/2 + 1 XZCRSR
	<p>XUBTAPSNM12</p>	2 x XZCR1511041C1/2 + 1 XZCRSR
	<p>XUK8AKSNM12</p>	2 x XZCR1511041C1/2 + 1 XZCRSR

# Chapter 6

## Wiring

### Overview

### WARNING

#### IMPROPER CONNECTION

- The XUSL4M safety light curtain system must be powered by a dedicated safety extra low voltage (SELV) or a protected extra low voltage (PELV)
- The transmitter and the receiver must be powered with a voltage of 24 Vdc  $\pm$  20%.
- The external power supply must comply with EN 60204-1.

**Failure to follow these instructions can result in death, serious injury, or equipment damage.**

The XUSL4M safety light curtain system operates directly from a 24 Vdc  $\pm$  20% power supply. The power supply must meet the requirements of EN/IEC 60204-1 and EN/IEC 61496-1. The SELV Schneider Electric part number ABL8RPS24... is recommended. For more information, refer to Power Supply ([see page 129](#)).

### WARNING

#### IMPROPER CONNECTION

- The XUSL4M safety light curtains must be connected using both safety outputs.
- The OSSD1 and OSSD2 output signals must not be connected between each other.
- A single safety output, if it fails, may not stop the machine.
- The Receiver provides a voltage of 24VDC on BOTH safety outputs. Therefore, the two loads must be individually connected between the corresponding safety output terminal and the 0VDC (OSSD1 --> LOAD1-->0VDC and OSSD2 -->LOAD2 --> 0VDC).
- When connecting high inductive loads to OSSDs, use suitable voltage suppressors on the outputs.
- The 0 Vdc must be common to all system components.

**Failure to follow these instructions can result in death, serious injury, or equipment damage.**

### What Is in This Chapter?

This chapter contains the following topics:

Topic	Page
Overview	<a href="#">94</a>
XUSL4MA and XUSL4MB Transmitter Electrical Connections	<a href="#">95</a>
XUSL4MB Receiver Electrical Connections	<a href="#">97</a>
XUSL4MA Receiver Electrical Connections	<a href="#">99</a>
Connection Schematics	<a href="#">101</a>

## Overview

### XUSL4M Models Electrical Connections

Before proceeding to the electrical connections, make sure that the available power supply voltage is in accordance with the data specified in the technical data.

### ***NOTICE***

#### **IMPROPER UTILIZATION**

In order to ensure the declared Environmental Degree of Protection (IP65-IP67), it is mandatory to protect the unused connectors with the provided protection caps.

**Failure to follow these instructions can result in equipment damage.**

### Precautions

- Make the connection to earth before making any other connections
- Connect XUSL4M before energizing

### Requirements for Connection Cables

- Conductor Size: 0.25...2.5 mm<sup>2</sup>
- It is required to keep the power supply of the XUSL4M separate from that of other electrical power equipment (electric motors, inverters, frequency changers) or other sources of disturbance
- For cables more than 20 m (65.62 ft) long, cables with a section of at least 0.5 mm<sup>2</sup> must be used (AWG16), 1 mm<sup>2</sup> with a length over 50 m (164.04 ft).
- Make sure the connectors are screwed down tightly to ensure correct safety light curtain operation.

## XUSL4MA and XUSL4MB Transmitter Electrical Connections

### Transmitter Connections

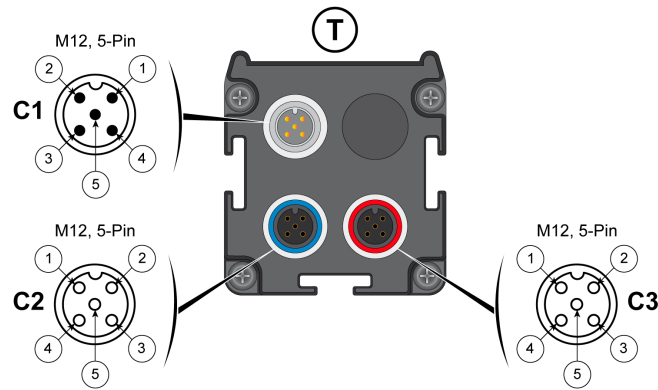

C1 - GRAY CONNECTOR - Range/Test selection male connector (M12, 5-Pin):

PIN	Signal	In/Out	Description
1	24 Vdc	-	Power supply 24 Vdc
2	RANGE0	Input	Sensing range selection
3	0 Vdc	-	Power supply 0 Vdc
4	RANGE1	Input	Sensing range selection
5	FE	-	Functional Earth connection

C1 - GRAY PIN CONNECTOR - Range and Test selection:

PIN 2	PIN 4	Function	Description
24 Vdc	0 Vdc	LOW Sensing range	For range values, refer to Safety Light Curtain Specifications ( <a href="#">see page 118</a> )
0 Vdc	24 Vdc	HIGH Sensing range	
0 Vdc	0 Vdc	TEST mode	Refer to Test Function ( <a href="#">see page 32</a> )
24 Vdc	24 Vdc	-	Condition not allowed

C2 - BLUE CONNECTOR - Female connector for muting sensors 1 and 2 (M12, 5-Pin):

PIN	Signal	In/Out	Description
1	24 Vdc	-	Sensor power supply 24 Vdc
2	SYNC	Output	Synchronization for XUSZAM arms or individual XUSZPM5•XPL09 multiple beams photocells
3	0 Vdc	-	Sensor power supply 0 Vdc
4	0 Vdc	-	Sensor power supply 0 Vdc
5	FE	-	Functional Earth connection

C3 - RED CONNECTOR - Female connector for muting sensors 3 and 4 (M12, 5-Pin):

PIN	Signal	In/Out	Description
1	24 Vdc	-	Sensor power supply 24 Vdc
2	SYNC	Output	Synchronization for XUSZAM arms or individual XUSZPM5•XPL09 multiple beams photocells
3	0 Vdc	-	Sensor power supply 0 Vdc
4	0 Vdc	-	Sensor power supply 0 Vdc
5	FE	-	Functional Earth connection

### Concerning 2 Sensors Muting Types

- When using XUSZASL2• integrated muting arms, the single output connector must be connected to the BLUE connector.
- When using XUSZAML2• or XUSZA•T2X• integrated muting arms, SENSOR 1 connector has to be wired on Sensor1 input (blue connector) and sensor 2 connector must be connected to the RED connector (sensor 3 input). Sensor 1 and sensor 2 can also be both connected to the BLUE connector through XZCRSR (for receiver) and XZCRSE (for transmitter) splitters.
- When using **T2X**, **L2P** or **L2X** muting types with two separate muting sensors (with 2 separate connectors):
  - Sensor 1 connector has to be wired on Sensor 1 input (Blue connector) and Sensor 2 connector must be connected to the Red connector (Sensor 3 input).
  - Sensor 1 and Sensor 2 can also be both connected to the Blue connector through **XZCRSR** (for receiver) and **XZCRSE** (for transmitter) splitters.
- In hardware configuration, the XUSL4M detects automatically the position of the connectors at the first switching of sensor 2 after power-up.
- In software configuration (XUSL4MA only), the physical position of the connectors must be set in accordance with SoMute software:

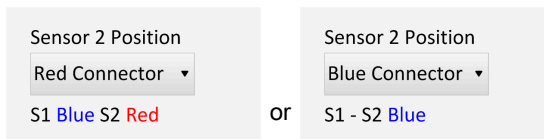



## XUSL4MB Receiver Electrical Connections

### Receiver Connections

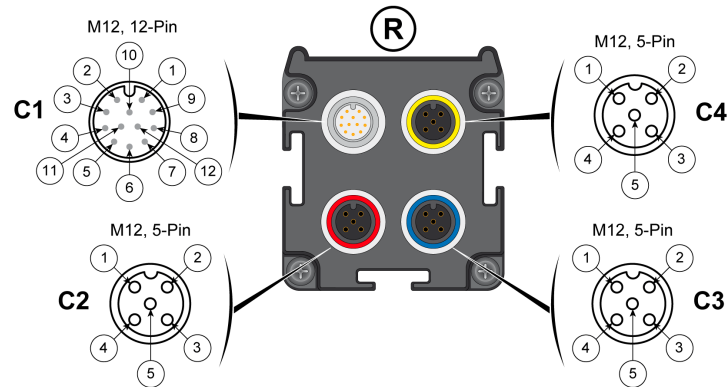

C1 - GRAY CONNECTOR - Main male connector (M12, 12-Pin):

PIN	Signal	In/Out	Description	Comments
1	24 Vdc	-	Power supply 24 Vdc	-
2	0 Vdc	-	Power supply 0 Vdc	-
3	OSSD1	Output	Static safety outputs	PNP output
4	OSSD2	Output		
5	FE	-	Functional Earth connection	-
6	SEL_A	Input	Muting type configuration	Refer to Operating Modes ( <a href="#">see page 28</a> )
7	MUT_ENABLE	Input	External muting enable	Refer to Muting Enable modes ( <a href="#">see page 48</a> )
8	EDM	Input	Feedback K1/K2	External contactors feedback, refer to EDM ( <a href="#">see page 30</a> )
9	OVERRIDE2	Input	Override request	Refer to Override ( <a href="#">see page 53</a> )
10	OVERRIDE1	Input	Override request	Refer to Override ( <a href="#">see page 53</a> )
	RESTART		Restart interlock	Refer to Manual Start/Restart ( <a href="#">see page 26</a> )
11	SEL_B	Input	Muting type configuration	Refer to Operating Modes ( <a href="#">see page 28</a> )
12	STATUS	Output	System status	PNP output (state of the OSSD outputs)

C2 - BLUE CONNECTOR - Female connector for muting sensors 3 and 4 (M12, 5-Pin):

PIN	Signal	In/Out	Description	Comments
1	24 Vdc	-	Sensor power supply 24 Vdc	-
2	SENSOR4	Input	SENSOR 4 status	< 5 Vdc: sensor cleared 11...30 Vdc: sensor interrupted
3	0 Vdc	-	Sensor power supply 0 Vdc	-
4	SENSOR3	Input	SENSOR 3 status or second Sensor (Sensor 2 status) in T2X configuration or 2 individual photocells (see NOTE below)	< 5 Vdc: sensor cleared 11...30 Vdc: sensor interrupted
5	FE	-	Functional Earth connection	-

C3 - RED CONNECTOR - Female connector for muting sensors 1 and 2 (M12, 5-Pin):

PIN	Signal	In/Out	Description	Comments
1	24 Vdc	-	Sensor power supply 24 Vdc	-
2	SENSOR2	Input	SENSOR 2 status	< 5 Vdc: sensor cleared 11...30 Vdc: sensor interrupted
3	0 Vdc	-	Sensor power supply 0 Vdc	-
4	SENSOR1	Input	SENSOR 1 status	< 5 Vdc: sensor cleared 11...30 Vdc: sensor interrupted
5	FE	-	Functional Earth connection	-

C4 - YELLOW CONNECTOR - Muting lamp female connector (M12, 5-Pin):

PIN	Signal	In/Out	Description	Comments
1	MUT_LAMP	Output	Muting lamp activation command	Active muting: 24 Vdc
2	(Not Connected)	-	-	-
3	0 Vdc	-	Muting lamp 0 Vdc	0 Vdc
4	(Not Connected)	-	-	-
5	(Not Connected)	-	-	-

Concerning 2 Sensors Muting Types

- When using XUSZASL2• integrated muting arms, the single output connector must be connected to the BLUE connector.
- When using XUSZAML2• or XUSZA•T2X• integrated muting arms, SENSOR 1 connector has to be wired on Sensor1 input (blue connector) and sensor 2 connector must be connected to the RED connector (sensor 3 input). Sensor 1 and sensor 2 can also be both connected to the BLUE connector through XZCRSR (for receiver) and XZCRSE (for transmitter) splitters.
- When using T2X, L2P or L2X muting types with two separate muting sensors (with 2 separate connectors):
  - Sensor 1 connector has to be wired on Sensor 1 input (Blue connector) and Sensor 2 connector must be connected to the Red connector (Sensor 3 input).
  - Sensor 1 and Sensor 2 can also be both connected to the Blue connector through XZCRSR (for receiver) and XZCRSE (for transmitter) splitters.
- In hardware configuration, the XUSL4M detects automatically the position of the connectors at the first switching of sensor 2 after power-up.
- In software configuration (XUSL4MA only), the physical position of the connectors must be set in accordance with SoMute software:

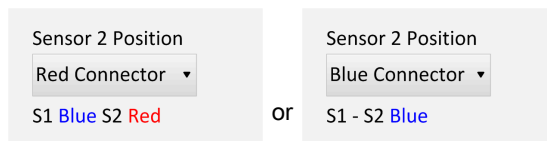

## XUSL4MA Receiver Electrical Connections

### Receiver Connections

Configurations with hardware wiring:

- The XUSL4MA safety light curtain factory settings do not provide any configuration. For configuring XUSL4MA models using a hardware wiring, refer to the XUSL4MB Receiver Electrical Connections ([see page 97](#)).
- In case the XUSL4MA is already programmed (blue led ON) it is necessary to reset the existing configuration for coming back at Factory Setting. To achieve this, use the command **DELETE CONFIGURATION** in SoMute software.

Configurations with SoMute software:

- To configure the XUSL4MA models with SoMute software, connect pins 1 and 2 (power supply) of the main 12 pins connector (DO NOT connect the other pins except the connections for EDM and/or Override and/or Manual Start and/or Muting Enable external signal if they are required).
- For switching from hardware to software configuration, respect at power-up the indication of the following table (main 12 pins connector):

SEL_A (pin 6)	SEL_B (pin 11)	MUT_ENABLE (pin 7)	EDM (pin 8)
0 Vdc (or open circuit)	0 Vdc (or open circuit)	0 Vdc (or open circuit)	<ul style="list-style-type: none"> <li>• 0 Vdc if EDM not requested by the software</li> <li>• Connected to 24 Vdc (through external relay NC contacts in series)</li> </ul>

To check the XUSL4MA model wiring with software configuration, refer to XUSL4M• as standalone ([see page 101](#)).

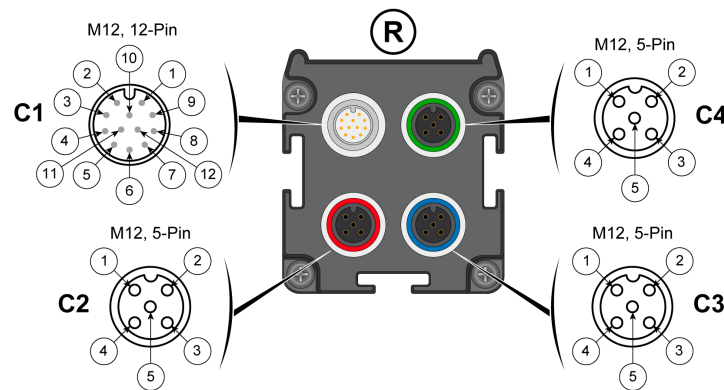

C1 - GRAY CONNECTOR - Main male connector (M12, 12-Pin):

PIN	Signal	In/Out	Description	Comments
1	24 Vdc	-	Power supply 24 Vdc	-
2	0 Vdc	-	Power supply 0 Vdc	-
3	OSSD1	Output	Static safety outputs	PNP output
4	OSSD2	Output		
5	FE	-	Functional Earth connection	-
6	SEL_A	Input	Muting type configuration	Refer to Operating Modes ( <a href="#">see page 28</a> )
	PARTIAL_MUTING		Control partial muting	The level of the PARTIAL MUTING ( <a href="#">see page 50</a> ) is set-up through the configuration software
7	MUT_ENABLE	Input	External muting enable	Refer to Muting Enable modes ( <a href="#">see page 48</a> )
8	EDM	Input	Feedback K1/K2	External contactors feedback, refer to EDM ( <a href="#">see page 30</a> )
9	OVERRIDE2	Input	Override request	Refer to Override ( <a href="#">see page 55</a> )
10	OVERRIDE1	Input	Override request	Refer to Override ( <a href="#">see page 55</a> )
	RESTART		Restart interlock	Refer to Manual Start/Restart ( <a href="#">see page 26</a> )
11	SEL_B	Input	Muting type configuration	Refer to Operating Modes ( <a href="#">see page 28</a> )
12	STATUS	Output	System status	PNP output (state of the OSSD outputs)

C2 - BLUE CONNECTOR - Female connector for muting sensors 3 and 4 (M12, 5-Pin):

PIN	Signal	In/Out	Description	Comments
1	24 Vdc	-	Sensor power supply 24 Vdc	-
2	SENSOR4	Input	SENSOR 4 status	< 5 Vdc: sensor cleared 11...30 Vdc: sensor interrupted
3	0 Vdc	-	Sensor power supply 0 Vdc	-
4	SENSOR3	Input	SENSOR 3 status or second Sensor (Sensor 2 status) in T2X configuration or 2 individual photocells (see NOTE below)	< 5 Vdc: sensor cleared 11...30 Vdc: sensor interrupted
5	FE	-	Functional Earth connection	-

C3 - RED CONNECTOR - Female connector for muting sensors 1 and 2 (M12, 5-Pin):

PIN	Signal	In/Out	Description	Comments
1	24 Vdc	-	Sensor power supply 24 Vdc	-
2	SENSOR2	Input	SENSOR 2 status	< 5 Vdc: sensor cleared 11...30 Vdc: sensor interrupted
3	0 Vdc	-	Sensor power supply 0 Vdc	-
4	SENSOR1	Input	SENSOR 1 status	< 5 Vdc: sensor cleared 11...30 Vdc: sensor interrupted
5	FE	-	Functional Earth connection	-

C4 - GREEN CONNECTOR - Muting lamp female connector, safety light curtain programming (M12, 5-Pin):

PIN	Signal	In/Out	Description	Comments
1	MUT_LAMP	Output	Muting lamp activation command	Active muting: 24 Vdc
2	USB+	In/Out	USB data	-
3	0 Vdc	-	Muting lamp 0 Vdc	0 Vdc
4	VBUS	Input	USB power supply	5 Vdc
5	USB-	In/Out	USB data	-

### Concerning 2 Sensors Muting Types

- When using XUSZASL2• integrated muting arms, the single output connector must be connected to the BLUE connector.
- When using XUSZAML2• or XUSZA•T2X• integrated muting arms, SENSOR 1 connector has to be wired on Sensor1 input (blue connector) and sensor 2 connector must be connected to the RED connector (sensor 3 input). Sensor 1 and sensor 2 can also be both connected to the BLUE connector through XZCRSR (for receiver) and XZCRSE (for transmitter) splitters.
- When using **T2X**, **L2P** or **L2X** muting types with two separate muting sensors (with 2 separate connectors):
  - Sensor 1 connector has to be wired on Sensor 1 input (Blue connector) and Sensor 2 connector must be connected to the Red connector (Sensor 3 input).
  - Sensor 1 and Sensor 2 can also be both connected to the Blue connector through **XZCRSR** (for receiver) and **XZCRSE** (for transmitter) splitters.
- In hardware configuration, the XUSL4M detects automatically the position of the connectors at the first switching of sensor 2 after power-up.
- In software configuration (XUSL4MA only), the physical position of the connectors must be set in accordance with SoMute software:

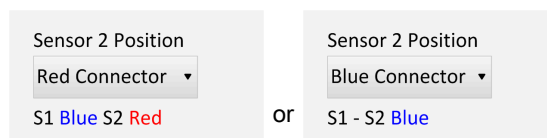

## Connection Schematics

### Connecting to a Safety Monitoring Device

The wiring from the XUSL4M safety light curtain system to the machine control circuit must be control reliable. The solid-state outputs must be connected only to a control reliable, safety-rated PLC or to a control reliable safety-rated machine system.

### XUSL4M as Standalone

The XUSL4M safety light curtains are designed to be used as standalone product when associated with contactors having mechanically linked contacts (force-guided) connected to the OSSDs (that is, without any safety relay, controller, or PLC).

This figure describes the connection of XUSL4MA safety light curtain system as standalone:

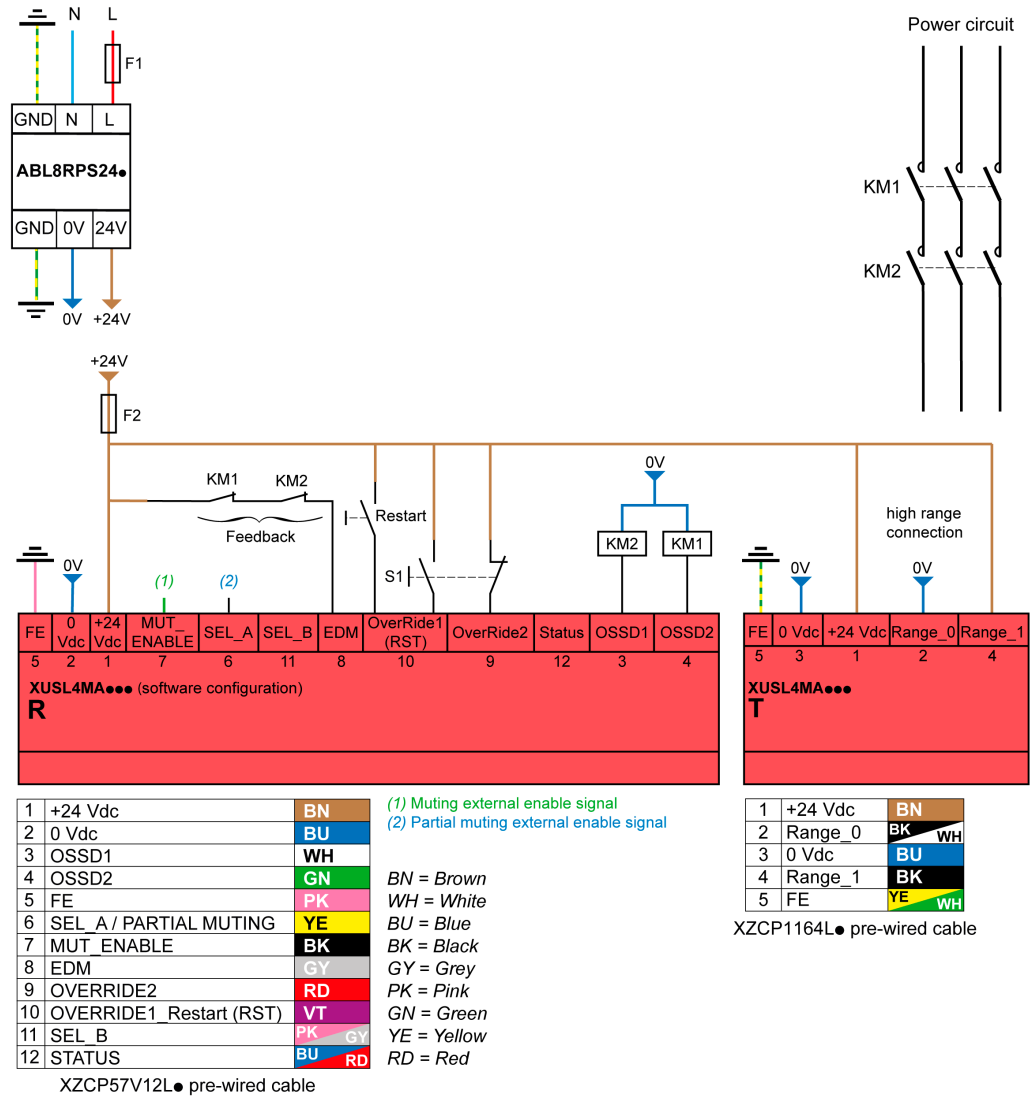

XUSL4MA receiver configured by software:

- Muting mode and timeout
- Manual start/restart
- EDM
- External Mut\_Enable
- Partial muting
- Push button override (Pulse action control)

XUSL4MA transmitter configured by hardware:

- High range (0...12m)

The muting sensors are managed by the safety light curtain (integrated muting function).

**⚠ WARNING**

**UNINTENDED EQUIPMENT OPERATION**

The KM1 and KM2 contactors must have force-guided contacts. Refer to External Device Monitoring ([see page 30](#)).

**Failure to follow these instructions can result in death, serious injury, or equipment damage.**

**Connecting with an XPS-AK Module**

This figure describes the connection of XUSL4M safety light curtain system with an XPS-AK module:

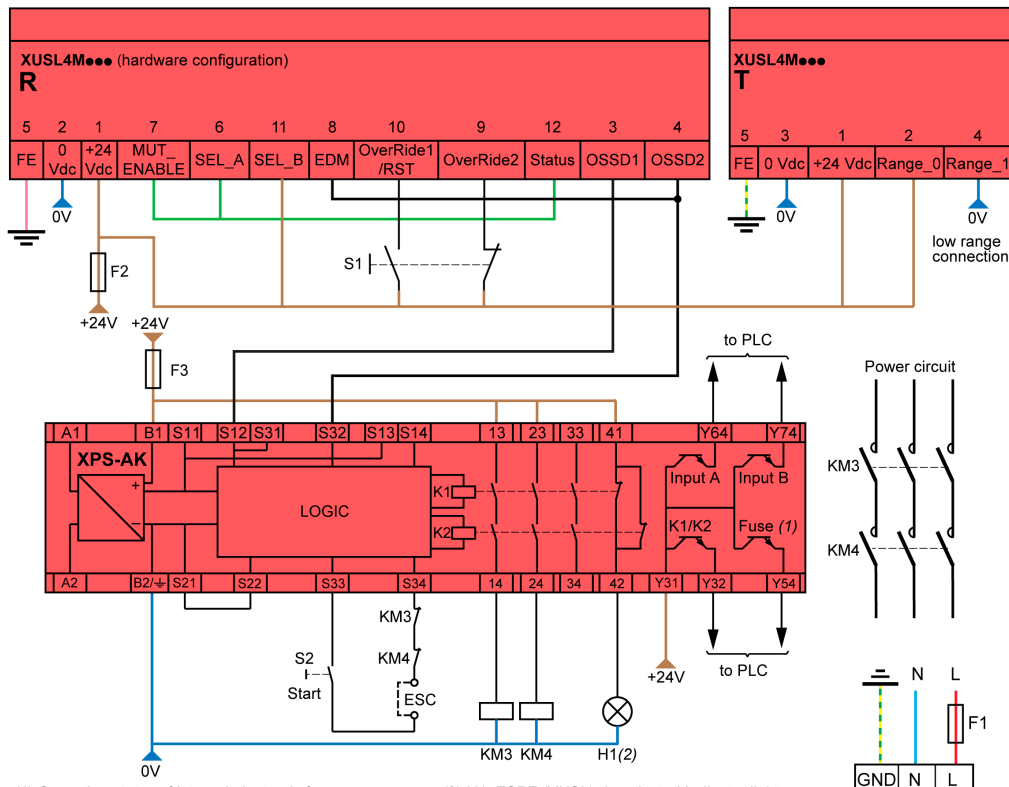

(1) Operating status of internal electronic fuse ESC: External start conditions (2) H1: ESPE (XUSL) deactivated Indicator light

XUSL4M... (R)	
1	+24 Vdc
2	0 Vdc
3	OSSD1
4	OSSD2
5	FE
6	SEL_A / PARTIAL MUTING
7	MUT_ENABLE
8	EDM
9	OVERRIDE2
10	OVERRIDE1 Restart (RST)
11	SEL_B
12	STATUS

- BN = Brown
- WH = White
- BU = Blue
- BK = Black
- GY = Grey
- PK = Pink
- GN = Green
- YE = Yellow
- RD = Red

XUSL4M... (T)	
1	+24 Vdc
2	Range_0
3	0 Vdc
4	Range_1
5	FE

XZCP1164L pre-wired cable

XZCP57V12L pre-wired cable

XUSL4M receiver configured by hardware:

- T2X muting mode timeout 9 h
- Manual start/restart\*
- With EDM\*
- Push button override (Pulse action control)
- Mut\_Enable disabled
- No external muting lamp

XUSL4M• transmitter configured by hardware:

- Low range (0...4 m)

The muting sensors are managed by the safety light curtain (integrated muting function).

\* When connected to a safety control unit, the safety light curtain receiver must be configured by wiring in automatic start and without EDM. The required start/restart and EDM modes are managed by the safety control unit.

**⚠ WARNING**

**UNINTENDED EQUIPMENT OPERATION**

The KM3 and KM4 contactors must have force-guided contacts. Refer to External Device Monitoring ([see page 30](#)).

**Failure to follow these instructions can result in death, serious injury, or equipment damage.**

**Connecting with an XPSMCM Controller**

This figure describes the connection of XUSL4M safety light curtain system with an XPSMCM controller:

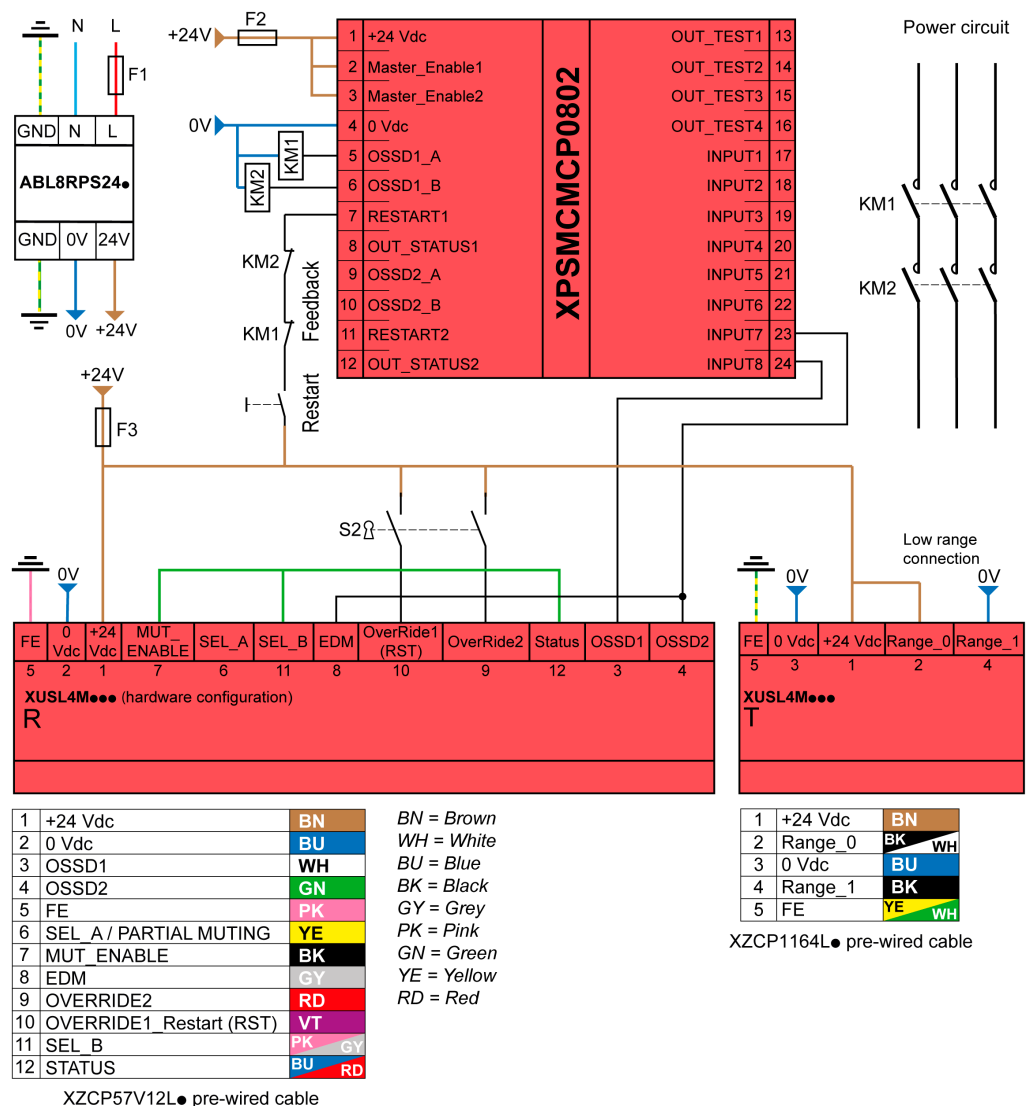

XUSL4M• receiver configured by hardware:

- T2X muting mode timeout 30s
- Manual start/restart\*
- With EDM\*
- Spring return key override (Hold-to-run action control)
- Mut\_Enable disabled
- No external muting lamp

XUSL4M• transmitter configured by hardware:

- Low range (0...4 m)

The muting sensors are managed by the safety light curtain (integrated muting function).

\* When connected to a safety control unit, the safety light curtain receiver must be configured by wiring in automatic start and without EDM. The required start/restart and EDM modes are managed by the safety control unit.

 <b>WARNING</b>
--

<b>UNINTENDED EQUIPMENT OPERATION</b>
---------------------------------------

The KM1 and KM2 contactors must have force-guided contacts. Refer to External Device Monitoring ( <a href="#">see page 30</a> ).
--

<b>Failure to follow these instructions can result in death, serious injury, or equipment damage.</b>
---



# Chapter 7

## Start Up

### Aligning the Transmitter and Receiver

#### General Description

The transmitter and receiver must be installed with the optical surfaces face to face, connectors oriented in the same way. Optimal alignment of the transmitter and the receiver corresponding beams is mandatory for an optimum functioning, meaning that the transmitter and receiver must have the same height and be parallel. A good positioning is facilitated by using the provided mounting accessories.

This figure describes the alignment of the transmitter and receiver:

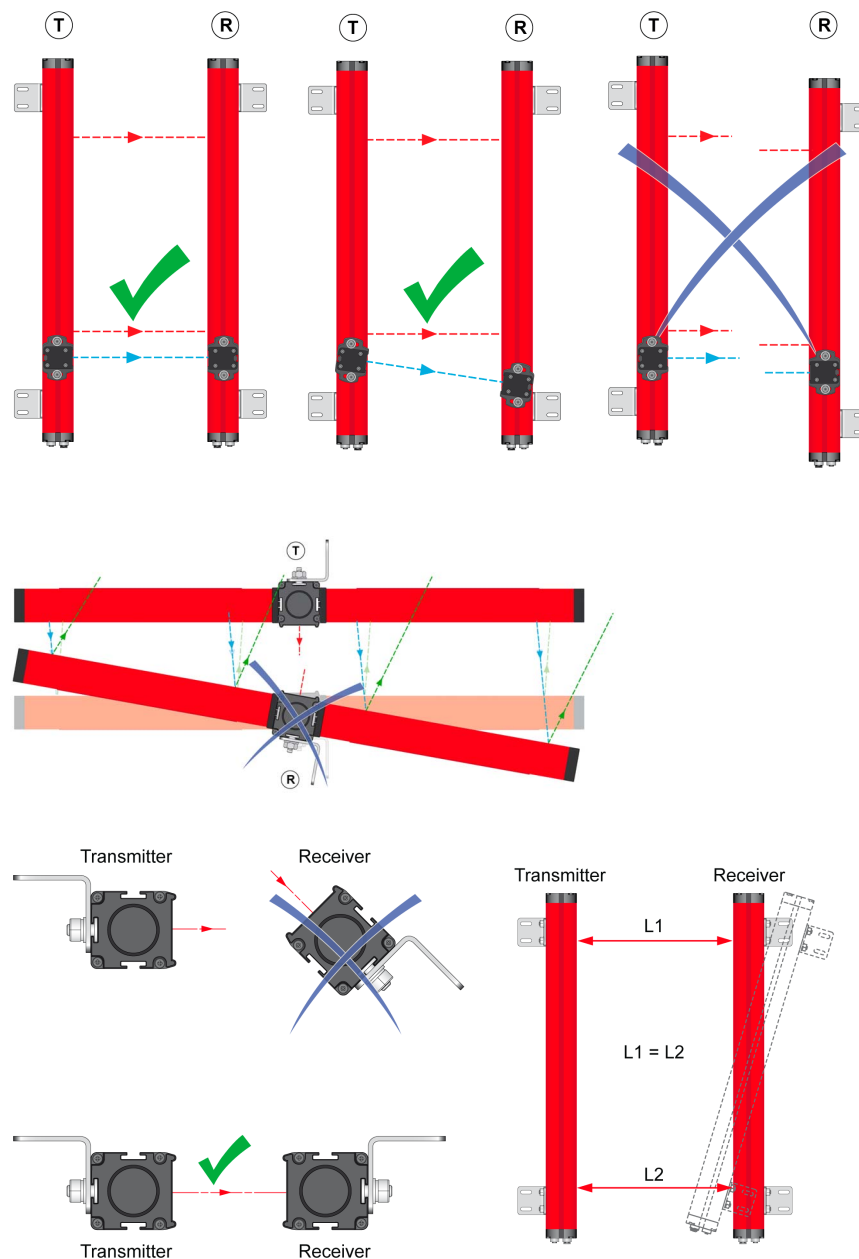

**Mechanical Assembly and Optical Alignment**

Mechanical assembly:

Step	Action
1	The transmitter and the receiver must be mounted one in front of the other at a distance equal to or less than indicated in the technical data. Using the supplied inserts and brackets, position the transmitter and the receiver so that they are aligned and parallel to each other and with the connectors facing the same side.
2	The optimal alignment between transmitter and receiver is required for the smooth operation of the safety light curtain; this operation is facilitated by observing the transmitter and receiver signaling LEDs.
3	Make electrical connections according to the wiring specifications ( <i>see page 93</i> ).

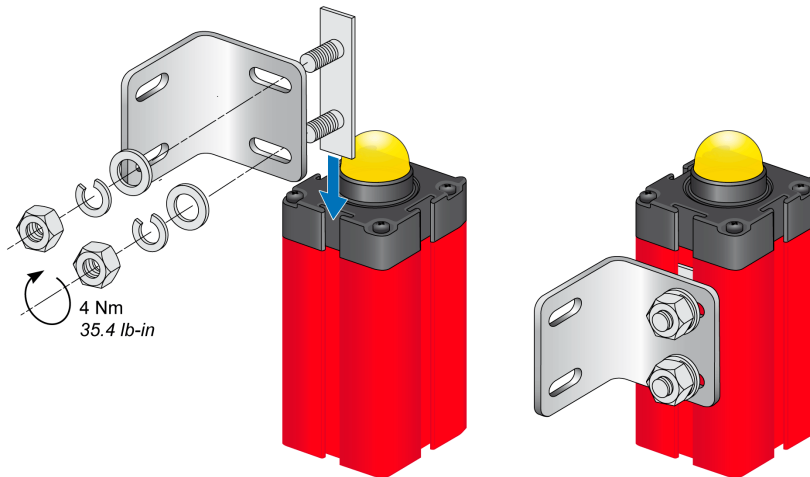

Optical alignment:

Step	Action
1	For an easier alignment setting, configure the safety light curtain in Automatic mode. That will avoid to restart the system during the alignment adjustments.
2	Place the optical axis of the first and last beams of the transmitter on the same axis as that of the corresponding beams on the receiver.
3	Move the transmitter to find the area within which the green LED on the receiver stays on; then place the first transmitter beam (the one near the signal LED) at the center of this area.
4	Using this beam as a pivot, with small lateral displacements of the opposite end, move to the free guarded area condition, which in this situation is indicated by turning on the green LED on the receiver.
5	Firmly tighten the transmitter and the receiver.
6	Do not forget to reconfigure the safety light curtain in Manual start mode if it is the operating mode required.

⚠ WARNING
IMPROPER SETUP OR INSTALLATION
If the transmitter and the receiver are mounted in areas subject to strong vibrations, in order not to compromise the operation of the circuits, it is necessary to use vibration dampers.
<b>Failure to follow these instructions can result in death, serious injury, or equipment damage.</b>

---

## Part IV

### Troubleshooting

---



---

# Chapter 8

## Receiver and Transmitter Troubleshooting

---

### Overview

This chapter describes the receiver and transmitter troubleshooting in detail.

### What Is in This Chapter?

This chapter contains the following topics:

Topic	Page
Transmitter Troubleshooting	110
Receiver Troubleshooting	111

## Transmitter Troubleshooting

### Fault Diagnosis - Transmitter

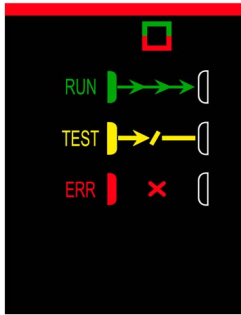

LED	Behavior	Meaning	Troubleshooting
	2 flashes	RANGE0/RANGE1 incorrect wiring.	Check pin 2-4 connections on the main connector
	3 or 4 flashes	Internal failure detected.	Contact the customer support in your country
	5 flashes	Synchronization incorrect wiring.	Check pin 2 connection on the muting sensor connectors

















## Receiver Troubleshooting

## Fault Diagnosis - Receiver









**NOTE:** In XUSL4MA models in addition to the corresponding led, when the operator connects XUSL4M to Computer via USB, a POP-UP window with the error code appears on the monitor.

Error Meaning	LED	Flashes	Troubleshooting
Configuration error SEL_A/SEL_B/EDM		2	Check pin 6-8-11 connections on the receiver main male connector
Incorrect EDM configuration		3	Check pin 8 connections on the receiver main male connector
EDM feedback failure		3	Check EDM feedback loop (for example KM1/KM2 contactor contacts)
		3	
STATUS input failure		3	Check pin 12 connections on the receiver main male connector
		3	
OVERRIDE_1 / OVERRIDE_2 input failure		3	Check pin 9-10 connections on the main male connector on the receiver
		3	
Muting SENSOR input failure		3	Check pin 2-4 connections on the muting sensor connectors
		3	
		3	
		3	
		3	

Error Meaning	LED	Flashes	Troubleshooting
Muting lamp failure		3	Check connections on the external lamp connector
		3	
		3	
		3	
OSSD1/OSSD2 error		4	Check pin 3-4 connections on the male connector on the receiver
Main card error		5	Contact the customer support in your country
Base sheet (EEPROM) error		5	Contact the customer support in your country
		5	
Main card error		5	Contact the customer support in your country
		5	
Main card (microcontroller) error		6	Contact the customer support in your country
Generic default board error		6	Check pin 6-7-8-9-10-11 connections on the male connector on the receiver
		6	
Beam error		6	Contact the customer support in your country
		6	
24 Vdc power supply overload		6	Check for a short-circuit on OSSD outputs
		6	



Error Meaning	LED	Flashes	Troubleshooting
LAMP/STATUS over current		6	Check for a short-circuit on pin 12 or auxiliary lamp connector
		6	
		6	
		6	
Beams reception failure		7	Contact the customer support in your country
Interfering transmitter detected		8	Verify the presence of another safety light curtain not correctly positioned Refer to Multiple Systems ( <a href="#">see page 76</a> )



---

## Part V

### Technical Characteristics

---



---

# Chapter 9

## Technical Characteristics

---

### Overview

This chapter describes the technical characteristics of the XUSL4M safety light curtain system.

### What Is in This Chapter?

This chapter contains the following topics:

Topic	Page
Safety Light Curtain Specifications	<a href="#">118</a>
Response Time and Safety Related Data	<a href="#">121</a>
Dimensions and Weights	<a href="#">124</a>
Muting Arms Dimensions	<a href="#">126</a>
Accessories	<a href="#">129</a>

## Safety Light Curtain Specifications

### Conformity/Approvals

The given table provides the standards:

Conforming to standards - XUSL4M	Type 4	EN 61496
	SIL 3	IEC 61508
	SILCL 3	IEC 62061
	PL e - Cat. 4	EN ISO 13849
Approvals	CE, cULus, TÜV	

### Environmental Specifications

The given table provides the temperature range specifications:

Reference	Models	Sensing Range	Resolution	Temperature range	
				Operating	Storage
XUSL4M	Type 4	Normal sensing range	30 mm (1.18 in)	-30...55 °C -22...131 °F	-30...70 °C -22...158 °F
			40 mm (1.57 in)		
			2-3-4 beams		

The given table provides the environmental specifications:

Environmental Characteristics	Description
Degree of protection*	Conforming EN/IEC 60529: IP65, IP67
Resistance to shock and vibration	Conforming to EN/IEC 61496-1: <ul style="list-style-type: none"> <li>● Shock: 10 g</li> <li>● Impulse: 16 ms</li> <li>● Vibration: 10...55 Hz</li> <li>● Amplitude: 0.35 ± 0.05 mm (0.0014 ± 0.00020 in)</li> </ul>
Materials	<ul style="list-style-type: none"> <li>● Housing: Aluminum (Red color: RAL 3000)</li> <li>● End caps: Polypropylene</li> <li>● Optical front panel: Polycarbonate</li> </ul>
<b>Environmental Chemicals</b>	
Chemical resistance	Aliphatic hydrocarbons
	Alcohols
	Detergents and cleansers
	Detergents and cleansers containing alkali products
* Devices are not suitable for outdoor use without supplementary measures	

### Optical Characteristics

The given table provides the optical characteristics:

Optical Characteristics	Description
Resolution or beams spacing	Resolution 30 mm (1.18 in) Resolution 40 mm (1.57 in) Beam spacing for multiple beams 300 mm (11.81 in), 400 mm (15.75 in), and 500 mm (19.68 in), respectively for 4, 3, and 2 beams.
Nominal range	0...4 m or 0...12 m selectable (0...13.12 ft or 0...39.37 ft)
Protected heights	310 mm...2260 mm (12.20 in...88.98 in)
Effective aperture angle	+/-2.5° maximum, transmitter and receiver at operating range > 3 m (9.84 ft) in accordance with EN/IEC 61496-2 (Type 4).
Light source	Infrared λ = 950 Nm
Resistance to light disturbance	In accordance with EN/IEC 61496-2.

## Electrical Characteristics

The given table provides the electrical characteristics:

Electrical Characteristics	Description
Response time	5.5...28 ms For more details, refer to Response Time and Safety Related Data ( <a href="#">see page 121</a> )
Power supply	24 Vdc $\pm$ 20%
Maximum current consumption (no load)	Transmitter: 42 mA Receiver: 83 mA
Resistance to interference	Conforming to EN/IEC 61496-1
Input power supply	Transmitter: 42 mA Receiver: 900 mA (Including OSSD current)
Safety outputs (OSSD)	2 PNP – 400 mA @ 24 Vdc
Signals	LED Signals on transmitter and receiver For more details, refer to Operating States ( <a href="#">see page 56</a> )
Connections	Power supply connector on Transmitter: M12 - 5-pin male Power supply connector on Receiver: M12 - 12-pin Male Muting sensor connectors / Muting lamp / Configuration: M12 – 5-pin Female
First-up time (time delay before availability)	$\leq$ 10 s
OSSDs Pulse Duration	$\leq$ 100 $\mu$ s
OSSDs Minimum pulse period	60 ms
OSSD Classification according to ZVEI (CB24I)	CL3
Resolutions for hand detection	30 mm – 40 mm (1.18 in – 1.57 in)
Protected height for hand detection	310 / 460 / 610 / 760 / 910 / 1060 / 1210 / 1510 / 1660 / 1810 / 1960 / 2110 / 2260 (mm) 12.20 / 18.11 / 24.01 / 29.92 / 35.83 / 41.73 / 59.45 / 65.35 / 71.26 / 77.16 / 83.07 / 88.98 (in)
Multiple beams for body detection	2/3/4 beams
Range	Low: 0...4 m (0...13.12 ft) High: 0...12 m (0...39.37 ft)
Power consumption (without load)	1 W (Transmitter) / 2 W (Receiver)
Configuration	Hardware on Receiver connector XUSL4MB models Hardware or software with USB connection <-> PC on XUSL4MA models
Cable gauge	0.25 mm <sup>2</sup> (AWG24) (0.5 mm <sup>2</sup> with length > 20 m / 1 mm <sup>2</sup> with length > 50 m)
Maximum cable length	100 m
STATUS Output	PNP – 100 mA @ 24 Vdc (shows the condition of the OSSD outputs)
EDM input	Available on Receiver, selectable
Restart Auto/Manual	Available on Receiver, selectable
Test input	Available on Transmitter, selectable

## NOTICE

### UNINTENDED EQUIPMENT OPERATION

Check that the OSSDs pulse pattern is compatible with the safety interface.

**Failure to follow these instructions can result in equipment damage.**

The given table provides the electrical characteristics for the muting function:

<b>Muting Function</b>	
Current rating available for Muting sensors	50 mA
Muting lamp output	24 Vdc / 0.5...5 W
Muting Signal Response Time (Muting sensors of pre-built muting arms)	100 ms
Time-out tempo max Muting	30 s, 90 min (all models) Can be 30 s or infinite with sequential muting type Configurable via software (XUSL4MA models only)
Muting Override	Selectable by Pulse or by Hold-to-run action control Configurable via software (XUSL4MA models only)
Override max time-out time	15 min (renewable) Configurable via software (XUSL4MA models only)
Max number of consecutive OVERRIDE	30
Muting type	Crossed or parallel beams, entry-exit or exit only
Muting type (XUSL4MA)	Fully configurable Muting type with SoMute software
Partial Muting (XUSL4MA)	Possibility to interrupt only a selected number of beams (only on software programmable models)
Tolerance time between sensor 1 and sensor 2	4 sec Configurable via software (XUSL4MA models only)
Muting lamp	Integrated lamp in the upper Receiver cap, LED technology (only on software programmable models XUSL4MA) External muting lamp on XUSL4MB models
Muting enable	Pin on main connector, disabled if not required and monitored



## Response Time and Safety Related Data

### General Description

This table provides safety-related data for XUSL4M safety light curtains:

Safety Light Curtain	Mission Time (TM)
XUSL4M	20 years

For safety-related data definitions, refer to Glossary.

### XUSL4M Ranges

30 mm resolution:

Reference		No. of Beams (to determine response time)	Response Time t <sub>1</sub> (ms)	PFH <sub>D</sub> (EN/IEC 61508)
Prefix	Protected Height (mm)			
<b>Hand Detection Models - Standard Sensing Range</b> Operating Range (m) = 0...4 or 0...12				
XUSL4M•30H	310	16	8	1.78 x 10 <sup>-8</sup>
	460	23	9.5	1.91 x 10 <sup>-8</sup>
	610	31	11	2.02 x 10 <sup>-8</sup>
	760	38	12.5	2.15 x 10 <sup>-8</sup>
	910	46	14.5	2.26 x 10 <sup>-8</sup>
	1060	53	16	2.39 x 10 <sup>-8</sup>
	1210	61	17.6	2.50 x 10 <sup>-8</sup>
	1360	68	19	2.63 x 10 <sup>-8</sup>
	1510	76	20.5	2.74 x 10 <sup>-8</sup>

40 mm resolution:

Reference		No. of Beams (to determine response time)	Response Time t <sub>1</sub> (ms)	PFH <sub>D</sub> (EN/IEC 61508)
Prefix	Protected Height (mm)			
<b>Hand Detection Models - Standard Sensing Range</b> Operating Range (m) = 0...4 or 0...12				
XUSL4M•40H	910	31	11	1.77 x 10 <sup>-8</sup>
	1060	36	12.5	1.85 x 10 <sup>-8</sup>
	1210	41	13.5	1.95 x 10 <sup>-8</sup>
	1360	46	14.5	2.03 x 10 <sup>-8</sup>
	1510	51	15.5	2.12 x 10 <sup>-8</sup>
	1660	56	16.5	2.21 x 10 <sup>-8</sup>
	1810	61	17.5	2.30 x 10 <sup>-8</sup>
	1960	66	18.5	2.38 x 10 <sup>-8</sup>
	2110	71	19.5	2.47 x 10 <sup>-8</sup>
	2260	76	20.5	2.56 x 10 <sup>-8</sup>

Multiple beams models:

Reference		No. of Beams (to determine response time)	Response Time t1 (ms)	PFH <sub>D</sub> (EN/IEC 61508)
Prefix	Protected Height (mm)			
<b>Body Detection Models - Standard Sensing Range</b> Operating Range (m) = 0...4 or 0...12				
XUSL4M•2B/3B/4B	-	2	5.5	8.97 x 10 <sup>-9</sup>
	-	3	5.5	9.63 x 10 <sup>-9</sup>
	-	4	5.5	1.03 x 10 <sup>-8</sup>

**XUSL4M with Arms**

<b>Muting Arms XUSZASL2PP - Muting type L 2 parallel beams (Transceiver + reflector)</b> <b>Muting Arms XUSZAST4PP - Muting type T 4 parallel beams (Transceiver + reflector)</b>	
Beams	2 single beam (XUSZASL2PP) 4 single beam (XUSZAST4PP)
Response time (ms)	100
Sensing range (m)	0...3.5

<b>Muting Arms XUSZASL2XT - Muting type L 2 crossed beams (Transmitter + Receiver)</b> <b>Muting Arms XUSZAST2XT - Muting type T 2 crossed beams (Transmitter + Receiver)</b>	
Beams	2 single beams
Response time (ms)	100
Sensing range (m)	1...2.5

<b>Muting Arms XUSZASL2PPS / XUSZASL2PPT - Muting type L 2 parallel beams (Transceiver + reflector)</b> <b>Muting Arms XUSZAST4PPS / XUSZAST4PPT - Muting type T 4 parallel beams (Transceiver + reflector)</b>	
Beams	2 single beams (XUSZASL2PP•) 4 single beams (XUSZAST4PP•)
Response time (ms)	100
Sensing range (m)	0...3.5 (XUSZASL2PPS, XUSZAST4PPS)
	0...2 (XUSZASL2PPT, XUSZAST4PPT)

<b>Muting Arms XUSZAML2XP (Transceiver + reflector) / XUSZAML2PTS (Transmitter + Receiver) - Muting type L with 2 XUSZPM5•XPL09 crossed/parallel photocells</b>	
Beams	2 multiple beams (5 beams)
Response time (ms)	100
Sensing range (m)	0...3.5
Sensor beams coding	SYNCHRO signal on
PFH <sub>D</sub> (single M5)	2.73 x 10 <sup>-07</sup>

<b>Muting Arms XUSZAMT2XT - Muting type T with 2 XUSZPM5•XPL09 (Transmitter + Receiver) crossed photocells</b>	
Beams	2 multiple beams (5 beams)
Response time (ms)	100
Sensing range (m)	0...3.5
Sensor beams coding	SYNCHRO signal on
PFH <sub>D</sub> (single M5)	2.73 x 10 <sup>-07</sup>

<b>Muting Arms XUSZAMT4PT (Transceiver + reflector) / XUSZAMT4PTS Transmitter + Receiver) with 4 XUSZPM5•XPL09 (Transmitter + Receiver) parallel photocells</b>	
Beams	4 multiple beams (5 beams)
Response time (ms)	100
Sensing range (m)	0...3.5
Sensor beams coding	SYNCHRO signal on
PFH <sub>D</sub> (one multiple beams sensor)	$2.73 \times 10^{-07}$

## Dimensions and Weights

### XUSL4M with 30 mm and 40 mm Resolution

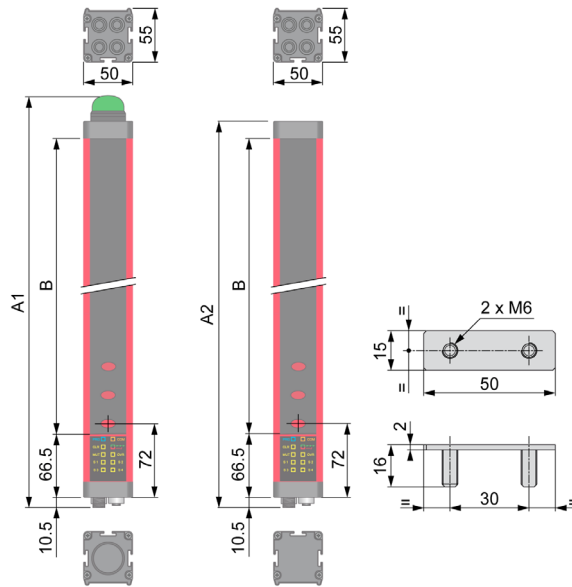

Safety light curtain dimensions and weights for XUSL4M with 30 mm and 40 mm resolution:

Models	A1 (mm)	A2 (mm)	B (mm)	Protected Height (mm)	Net Weight (kg)
300	420	395	300	310	2.21
450	570	545	450	460	2.85
600	720	695	600	610	3.49
750	870	845	750	760	4.38
900	1020	995	900	910	5.02
1050	1170	1145	1050	1060	5.66
1200	1320	1295	1200	1210	6.30
1350	1470	1445	1350	1360	6.94
1500	1620	1595	1500	1510	7.58
1650	1770	1745	1650	1660	8.24
1800	1920	1895	1800	1810	8.88
1950	2070	2045	1950	1960	9.52
2100	2220	2195	2100	2110	10.16
2250	2370	2345	2250	2260	10.80

XUSL4M with 2/3/4 Beams

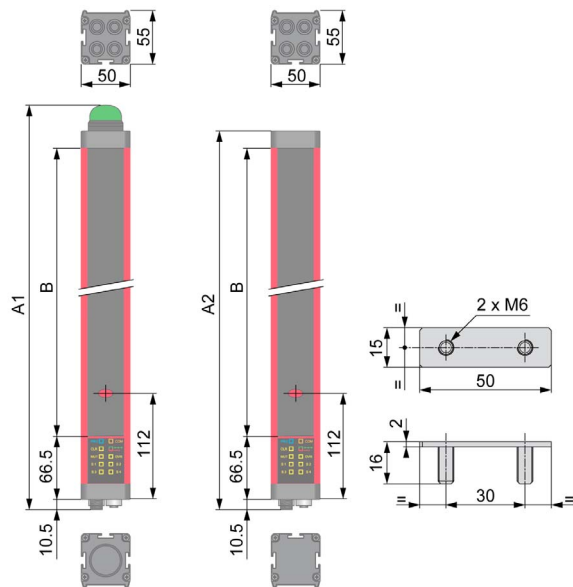

Safety light curtain dimensions and weights for XUSL4M with 2/3/4 beams:

Models	A1 (mm)	A2 (mm)	B (mm)	Protected Height (mm)	Net Weight (kg)
2B	710	685	590	510	3.31
3B	1010	985	890	810	4.76
4B	1110	1085	990	910	5.18

## Muting Arms Dimensions

### Overview

XUSZASL2XT for L2X configuration with 2 crossed Transmitter/Receiver single beams:

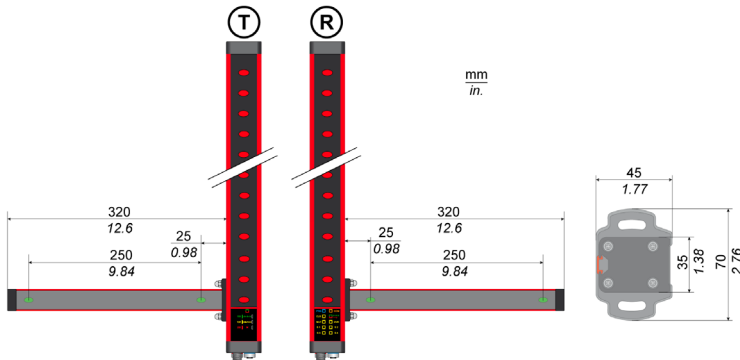

XUSZAML2XT / XUSZAML2PTS (for high-speed conveyors) for L2X and L2P configurations with 2 crossed or parallel adjustable beams (XUSZPM5AXPL09 and XUSZPM5BXPL09 multiple beams muting sensors):

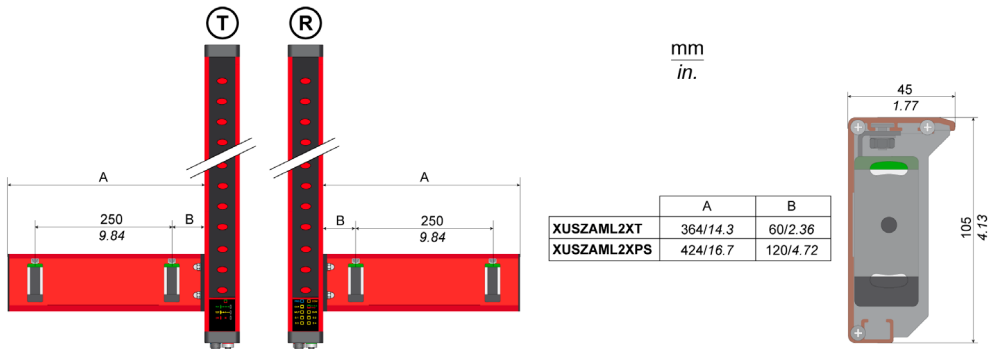

XUSZASL2PP / XUSZASL2PPT (for detection of transparent objects) / XUSZASL2PPS (for high-speed conveyors) for L2P configuration with 2 parallel single beams with reflector:

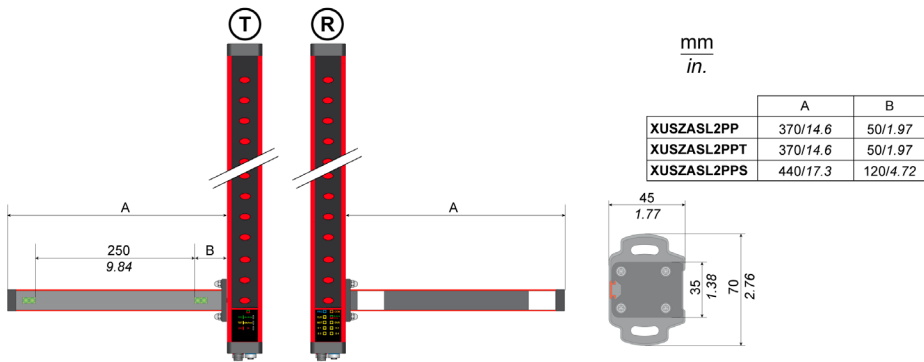

XUSZAST2XT for T2X configuration with 2 crossed Transmitter/Receiver single beams:

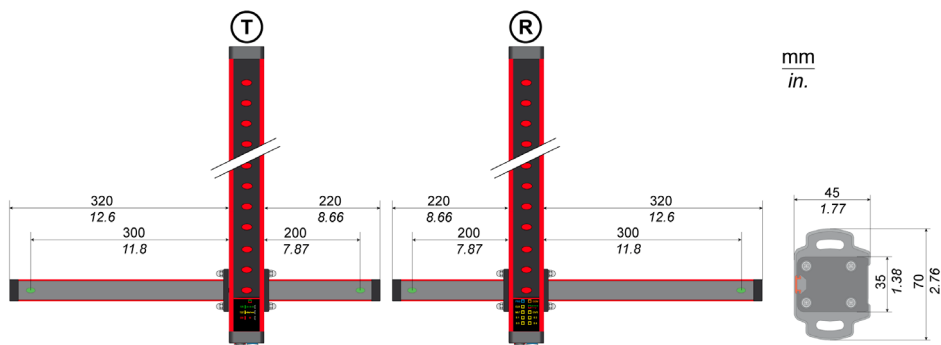

XUSZAMT2XT for T2X configuration with 2 adjustable crossed beams (XUSZPM5AXPL09 & XUSZPM5BXPL09 multiple beams muting sensors):

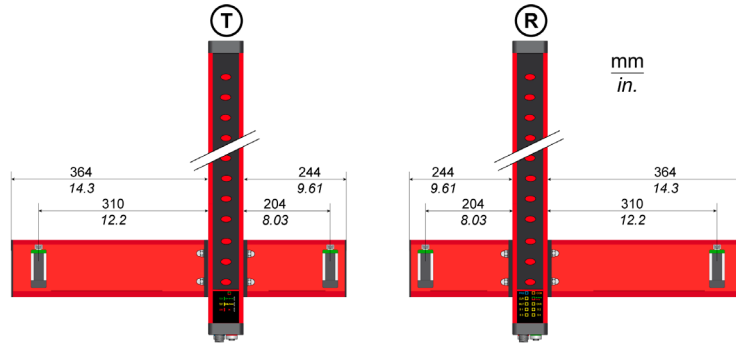

XUSZAST4PP / XUSZAST4PPT (for detection of transparent objects) / XUSZAST4PPS (for high-speed conveyors) for T4P configuration with 4 adjustable parallel single beams:

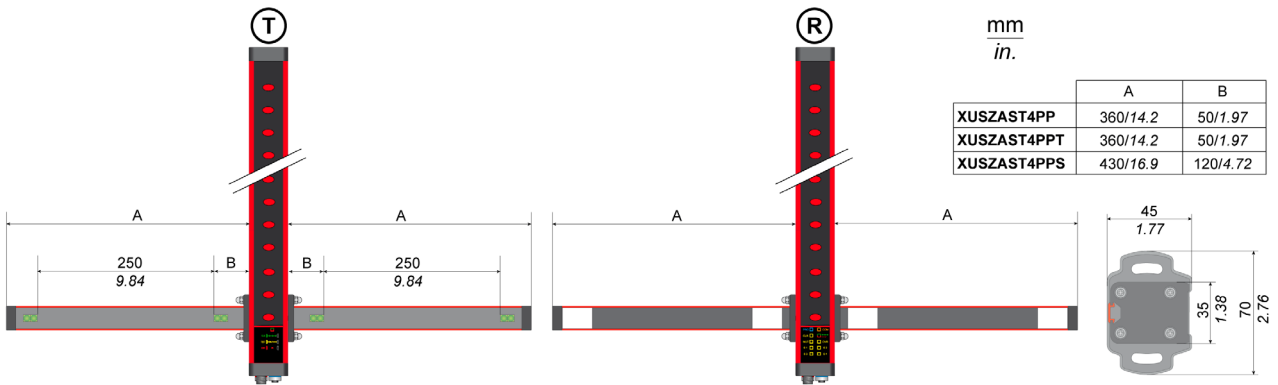

XUSZAMT4PT (for detection of transparent objects) / XUSZAMT4PTS (for high-speed conveyors) for T4P configuration with adjustable parallel beams (XUSZPM5AXPL09 and XUSZPM5BXPL09 multiple beams muting sensors):

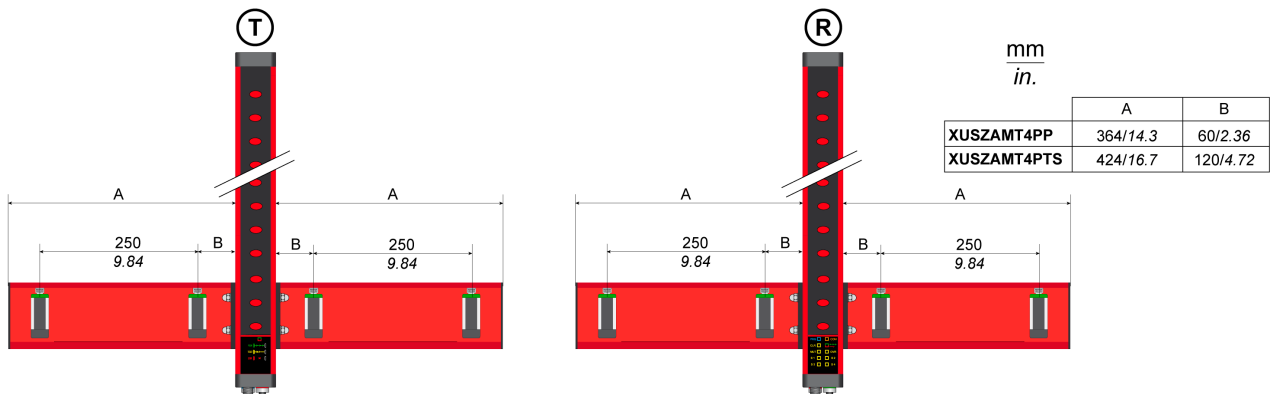

Muting Arm Weight

Muting Arms reference	Net Weight (kg)
XUSZAST4PPT	2.48
XUSZAST4PPS	2.88
XUSZAST4PP	2.48
XUSZAST2XT	1.85
XUSZASL2XT	1.17
XUSZASL2PPT	1.25
XUSZASL2PPS	1.45
XUSZASL2PP	1.25
XUSZAMT4PTS	3.39
XUSZAMT4PT	3.07
XUSZAMT2XT	2.27
XUSZAML2PTS	1.69
XUSZAML2XP	1.53



## Accessories

### Power Supply

The power supply must meet the requirements of EN/IEC 60204-1 and EN/IEC 61496-1. The SELV Schneider Electric part number ABL8RPS24... is recommended.

This figure describes the power supply ABL8RPS24...:

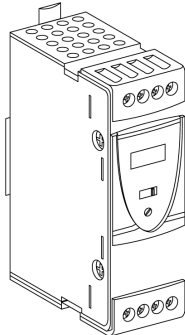

**ABL8RPS24... Operating temperature range -25...60 °C without derating:**

Input voltage	Secondary			Reset	Conforming to standard EN 61000-3-2	Reference
	Output voltage (V)	Nominal power (W)	Nominal current (A)			
Single to phase (N-L1) 100...120 Vac -15 +10% (50 Hz or 60 Hz)	24...28.8	72	3	Auto/Manual	Yes	ABL8RPS24030
		120	5	Auto/Manual	Yes	ABL8RPS24050
		240	10	Auto/Manual	Yes	ABL8RPS24100
Phase to phase (L1-L2) 200...500 Vac -15 +10% (50 Hz or 60 Hz)						

Fixing Brackets

Fixing brackets given below are provided with the safety light curtain pairs and segments.

This figure describes these fixing brackets:

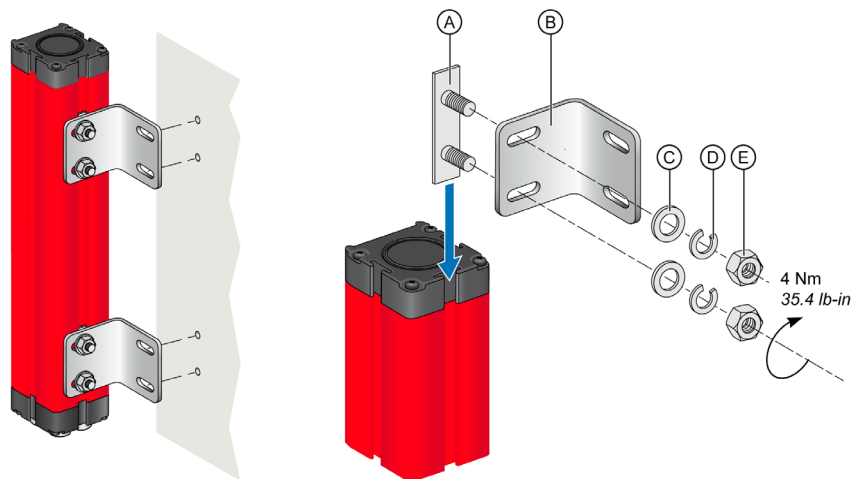

- A Insert
- B Bracket
- C Washer
- D Spring washer
- E Nut

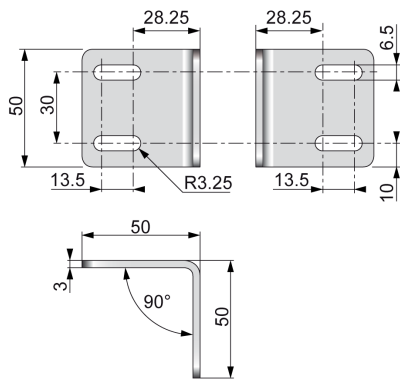

### Special Fixing Brackets

Special brackets are suitable for adaptation of the existing mechanical support, long range applications, or with defective mirrors.

This table describes the different types of brackets:

Bracket type	Description	Figure
Curved	Allows the rotation over 14° along longitudinal axis of the safety light curtain.	<p>The figure illustrates the assembly and dimensions of a curved bracket. It includes:         <ul style="list-style-type: none"> <li>An exploded view showing the bracket (1) being attached to a red sensor housing (2) using screws (3), washers (4), and nuts (5). A torque specification of 4 Nm (35.4 lb-in) is indicated for the nuts.</li> <li>A side view of the bracket showing a 90° ± 10° angle and radii of R 57 and R 2.24. Dimensions include a height of 50 mm (1.97 in.), a horizontal length of 54.3 mm (2.14 in.), and a vertical offset of 25.5 mm (1 in.).</li> <li>A top view showing two mounting slots with a width of 13.5 mm (0.53 in.) and a distance of 30 mm (1.18 in.) between them. The hole diameter is Ø 6.5 mm (Ø 0.26 in.).</li> <li>A perspective view showing the bracket's rotation range of 7°.</li> </ul> </p>

This table provides the references of the special fixing brackets:

Reference	Maximum Protected Height (mm)	Description	Net Weight (kg)
XUSZBMC4	Up to 1060	Set of 4 curved brackets	0.49
XUSZBMC6	From 1210	Set of 6 curved brackets	0.74

Fixing Base

The columns fixing base system allows a robust mounting on the floor with a possibility to adjust the transmitter and receiver alignment accurately.

This figure displays the simple column fixing base:

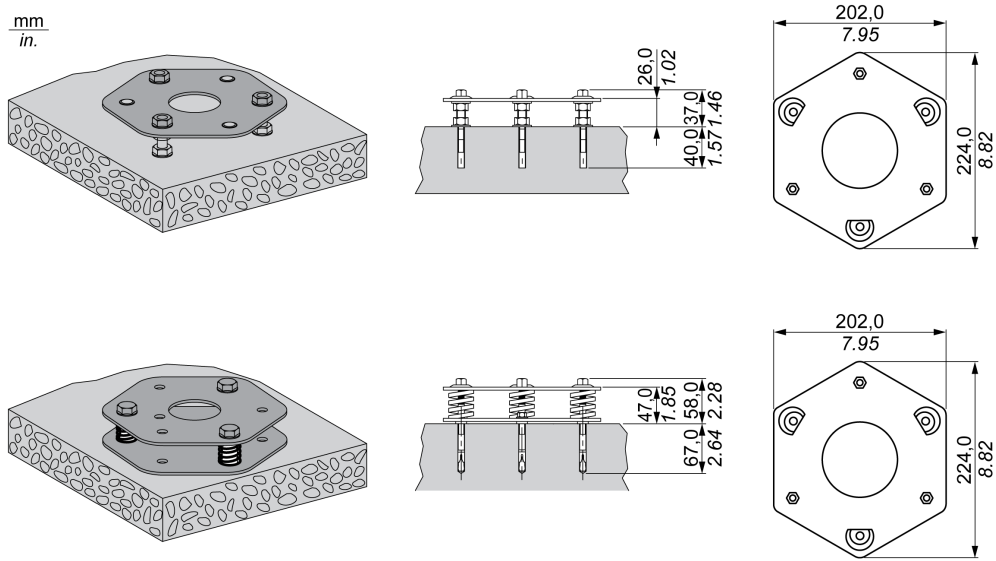

This table describes the environmental characteristics and references of the column fixing base:

Column fixing base				
References				
	Reference	Height (mm)	Dimensions	Net Weight (kg)
One fixing base has to be ordered for each column.	XUSZFB2 (Double fixing base)	47	202 x 224 x 58 h	2.2
	XUSZFB1 (Simple fixing base)	26	202 x 224 x 37 h	1.0

The double plate is suitable for mounting with columns ([see page 133](#)). The positioning setting is facilitated by the springs and adjustment screws.

Column

Columns are used to protect safety light curtain systems in case of shock or flying part risks in the application. A built-in spirit level form a useful help for vertical axis positioning.

This figure describes the fixing columns:

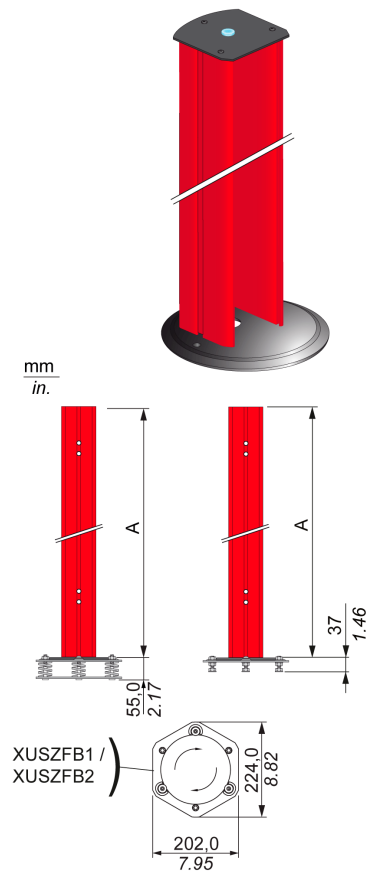

**NOTE:** The columns must be mounted on XUSZFB1 or XUSZFB2 floor mounting bases (to be ordered separately).

**NOTE:** The use of straight connectors for the Transmitter and Receiver connection is mandatory when using protection columns XUSZSC... (90° connectors are not suitable).

This figure displays the distance between the first beam and the floor (H) (According to ISO 13855):

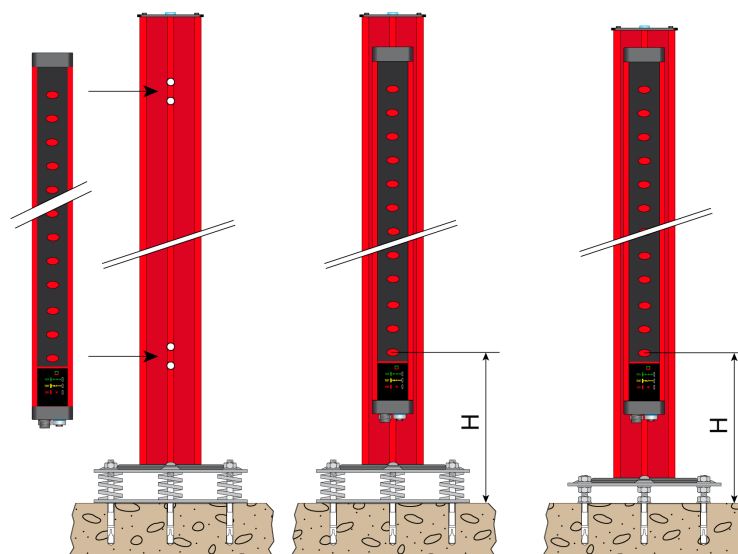

This table describes the distance between the first beam and floor (H):

Reference	H (mm)
XUSZSM2B	<400 (< 15.7 in.) <sup>(1)</sup>
XUSZSM3B	<300 (<11.8 in.)
XUSZSM4B	
XUSZSM136	
XUSZSM166	
<b>(1)</b> For the lowest beam, 400 mm (15.7 in.) can only be used when the risk assessment allows it.	

This table describes the references of the fixing column without mirror:

Reference	For use with safety light curtains	Height (A) (mm)	Net Weight (kg)
XUSZSM2B	2 beams	1000 (39.37 in.)	3.2
XUSZSM3B	3 beams	1200 (47.24 in.)	3.7
XUSZSM4B	4 beams	1330 (52.36 in.)	4
XUSZSM136	For R=30 mm or 40 mm.	Protected height up to: 1360 (53.54 in.)	4.9
XUSZSM166		Protected height up to: 1660 (65.35 in.)	5.6

**Test Rod**

The test rod is an opaque metallic cylindrical stick used to check no beams are bypassed due to the presence of reflecting surfaces.

This figure displays the test rod moving along the detection zone:

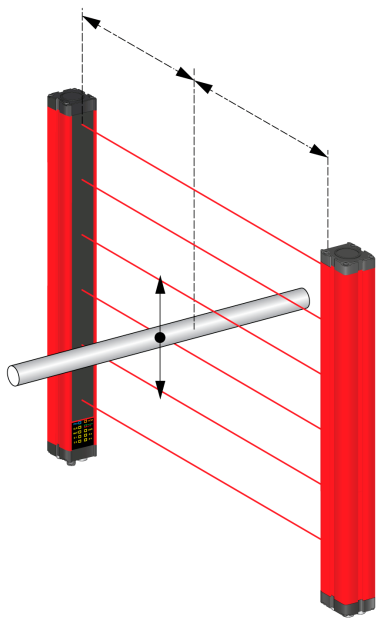

This table describes the references for the test rod:

Reference	Diameter (mm)	Net Weight (kg)
XUSZTR30	30	0.07
XUSZTR40	40	0.08

For more information about testing methods with the test rods, refer to Test procedure ([see page 74](#)).

The test rods are not supplied with the safety light curtains and must be ordered separately.

Cables

This table describes the main connector 5-pin transmitter cables:

PUR Cables (Transmitter - 5 pins)	Description
XZCP1164L2	Connector M12 - Female - Straight - 5 poles - 2 m pre-wired
XZCP1164L5	Connector M12 - Female - Straight - 5 poles - 5 m pre-wired
XZCP1164L10	Connector M12 - Female - Straight - 5 poles - 10 m pre-wired
XZCP1164L15	Connector M12 - Female - Straight - 5 poles - 15 m pre-wired
XZCP1164L25	Connector M12 - Female - Straight - 5 poles - 25 m pre-wired
XZCC12FDM50B	Connector M12 - Female - Straight - 5 poles with screw terminals-cable gland - Metal clamping ring

**NOTE:** Cable with 90° connector must not be used.

This table describes the pin-wire connections for the main connector 5-pin transmitter cables:

Connector	Pin Number	Wire Color	XUSL Description
	1	Brown	Power supply 24 Vdc
	2	Black/White	Range selection
	3	Blue	Power supply 0 Vdc
	4	Black	Range selection
	5	Yellow/Green	FE (Functional Earth connection)

This table describes the main connector 12-pin receiver cables:

PVC Cables (Receiver - 12 pins)	Description
XZCP57V12L3	Connector M12 - Female - Straight - 12 poles - 3 m
XZCP57V12L5	Connector M12 - Female - Straight - 12 poles - 5 m
XZCP57V12L10	Connector M12 - Female - Straight - 12 poles - 10 m
XZCP57V12L15	Connector M12 - Female - Straight - 12 poles - 15 m
XZCP57V12L20	Connector M12 - Female - Straight - 12 poles - 20 m

This table describes the pin-wire connections for the main connector 12-pin receiver cables:

Connector	Pin Number	Wire Color	XUSL Description
	1	Brown	Power supply 24 Vdc
	2	Blue	Power supply 0 Vdc
	3	White	OSSD1 Safety static outputs
	4	Green	OSSD2 Safety static outputs
	5	Pink	FE (Functional Earth connection)
	6	Yellow	Muting configuration
	7	Black	External muting enable
	8	Gray	Feedback K1/K2
	9	Red	Override request
	10	Violet	Override request / Restart Interlock
	11	Gray/Pink	Muting configuration
	12	Red/Blue	System status

This table describes the connection accessories:

PVC Cables	Description
XZCRPC <sup>1</sup>	USB- M12-5 pins adapter for safety light curtain programming
XZCRSR	Y-M12-5 pins splitters for the connection of 2 muting sensors in T4P muting type - receiver
XZCRSE	Y-M12-5 pins splitters for the connection of 2 muting sensors in T4P muting type - emitter
<b>1</b> For XUSL4MA only	

This table describes the cables for external lamp connection:

PUR Cables	Description	Pin color	Length
XZCP1541L1	Pre-wired 4 wires for external lamp connection (Connector M12 - Male - 4 poles)	pin 1: Brown pin 2: White pin 3: Blue pin 4: Black	1 m
XZCP1541L2			2 m
XZCP1541L5			5 m
XZCP1541L10			10 m

This table describes the cables for individual photocell muting sensors connection:

PUR Cables	Description	Length
XZCR1509040H1	Jumper M12-5 pins male M8-4 pins female For XUM individual photocell muting sensors connection	1 m
XZCR1509040H2		2 m
XZCR1511041C2	Jumper M12-5 pins/4 wires male - M12-5 pins/4 wires female For XUK and XUB individual photocell muting sensors connection	2 m
XZCR1511041C3		3 m
XZCR1511041C10		10 m
XZCR1511041C20		20 m



---

# Part VI

## SoMute Software

---

### What Is in This Part?

This part contains the following chapters:

Chapter	Chapter Name	Page
10	SoMute Presentation	<a href="#">139</a>
11	SoMute Features	<a href="#">145</a>
12	SoMute Settings	<a href="#">155</a>



---

# Chapter 10

## SoMute Presentation

---

### What Is in This Chapter?

This chapter contains the following topics:

Topic	Page
General Information	<a href="#">140</a>
Software Installation	<a href="#">141</a>
Graphical Interface	<a href="#">142</a>
Toolbar	<a href="#">143</a>

## General Information

### Description

By connecting the XUSL4MA safety light curtain to the PC through the USB connection, the SoMute software allows the configuration of the safety light curtain characteristics, allowing you to set all the parameters for a proper operation of the safety light curtain and muting function.

After verifying that the system is working correctly, the operator will no longer need connection to the PC and the safety light curtain can work autonomously.

If you want to monitor the safety light curtain operation by PC continuously, leave the USB connection enabled with safety light curtain.

Configuration is possible in a few simple steps through the graphical interface of SoMute.

## Software Installation

### Hardware Requirements

Hardware characteristics requested by the PC for connection:

- RAM memory: 1 GB (sufficient enough to operate Windows 7 SP1 + Framework 4.0)
- Hard disk: clear space > 500 MB
- USB connector: 1.1, 2.0, or 3.0

### Software Requirements

Windows 7 with Service Pack 1 installed (or higher OS) is requested by the PC for connection.

**NOTE:** Microsoft Framework 4.0 (or higher) must be installed on your computer.

During SoMute setup phase, the installation of the XUSL4M Windows driver is mandatory to establish a proper communication between the PC and XUSL4M USB connection.

### How to Install SoMute

To install:

Step	Action
1	<p>Download the SoMute software from <a href="http://www.tesensor.com">www.tesensor.com</a> or flash the QR code to access XUSL4M download area:</p>  <p><b>NOTE:</b> The QR code is also present on the safety light curtain label.</p>
2	<p>Wait for the program installer to request the SET-UP of the software. Alternatively, double-click the SET-UP.exe file.</p>
3	<p>Once installed, a window appears asking for the shutdown of the set-up program.</p>

**NOTE:** To program XUSL4MA models, it is mandatory that pin 6 and 11 of the 12-pin connector on the receiver detect 0 Vdc (or open circuit).



## Graphical Interface

### Main Window

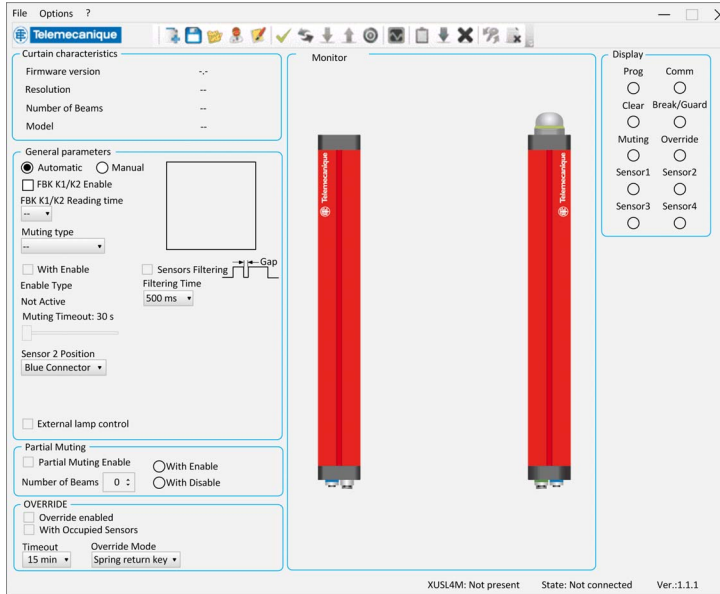
At start-up, the software shows the following initial screen:



The operator can decide whether:

- To create a new configuration (icon ).
- To load a previously created configuration (icon ).

To proceed with the configuration, after the connection with the safety light curtain, a password is required:

- Level 1 password  
The operator authorized to read the configuration must know a level 1 password. At the first system initialization, the operator must use the password "" (ENTER key). The operator who knows the level 2 password is enabled to enter a new level 1 password (alphanumeric, maximum eight characters).
- Level 2 password  
The operator authorized to create the configuration and load it into the safety light curtain must know a level 2 password. At initial system initialization, the operator must use the SAFEPASS password (all capital letters). The operator who knows the level 2 password is enabled to enter a new level 2 password (alphanumeric, maximum eight characters).

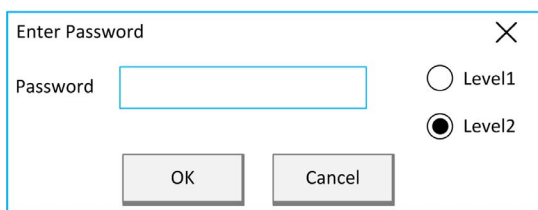

## WARNING

### UNAUTHORIZED ACCESS

To protect the safety light curtain system against unauthorized access, it is strongly advised to modify the level 1 and level 2 factory setting passwords.

The new passwords have to be robust enough to provide a sufficiently high security level (alphanumeric, maximum eight characters).

**Failure to follow these instructions can result in death, serious injury, or equipment damage.**

**NOTE:** If lost, there is no possibility to “reset” the level 2 password. In such a case, contact the customer support of your country.

## Toolbar

### Toolbar Icons

The standard toolbar is reproduced in the figure below and the meaning of the different icons is listed:



Icon	Description
	Create new safety light curtain configuration
	Save configuration on hard disk
	Load configuration from hard disk
	Project information
	Print configuration report ( <i>see page 150</i> )
	Configuration validation ( <i>see page 149</i> )
	Connection to the safety light curtain ( <i>see page 146</i> )
	Download configuration (read configuration from the safety light curtain)
	Upload configuration (send configuration to the safety light curtain) For more details, refer to Configuration Validation and Loading ( <i>see page 149</i> )
	Disconnection (or Restart in case of disconnected safety light curtain)
	Monitor safety light curtain state (graphics and text)
	Configuration history (read from the safety light curtain)
	Errors download (read from the safety light curtain) For more details, refer to the Errors Table ( <i>see page 151</i> )
	Error history cancellation (erase safety light curtain error history)
	Modify password
	Configuration deletion (erase safety light curtain configuration)





---

# Chapter 11

## SoMute Features

---

### What Is in This Chapter?

This chapter contains the following topics:

Topic	Page
Connection	<a href="#">146</a>
Viewing of Safety Light Curtain Configuration	<a href="#">147</a>
Programming (Configuration by Software)	<a href="#">148</a>
Configuration Check	<a href="#">149</a>
Report Configuration	<a href="#">150</a>
Errors Log	<a href="#">151</a>
Safety Light Curtain Activation	<a href="#">153</a>
Monitoring of the Safety Light Curtain Operation	<a href="#">154</a>

## Connection

### Connection with the Safety Light Curtain

- Connect the PC to the safety light curtain (icon ).
- After entering the password, the following screen appears:

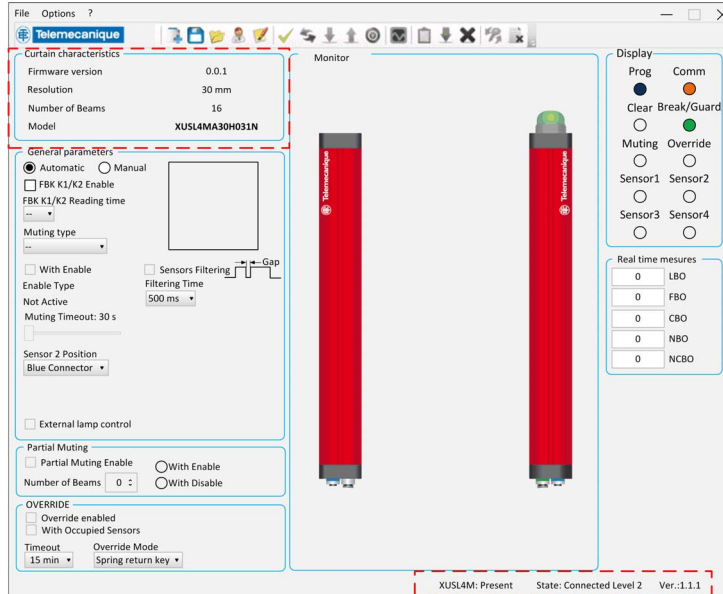

At this stage, you have a static reading of the safety light curtain condition, as the safety light curtain is still not in operation.

The dotted areas In the screenshot above highlight some information:

- General characteristics of the safety light curtain
- Password level
- Connected/Disconnected
- Software version

---

## Viewing of Safety Light Curtain Configuration

### Download Configuration

In order to view the safety light curtain configuration, it is necessary to request a download of the

configuration (icon ).

**NOTE:** Otherwise, a safety light curtain configuration procedure is required.

## Programming (Configuration by Software)

### Safety Light Curtain Programming

To configure the safety light curtain properly, you must set parameters for **General parameters**, **Partial Muting**, and **OVERRIDE** dialog boxes.

**NOTE:** Programming (PRG) (blue) and Communication (COM) (yellow) leds are lit during programming.

**NOTE:** Refer to chapter SoMute Settings ([see page 155](#)) for the meaning of the various parameters and their possible options.

The screenshot shows the configuration interface for a safety light curtain, divided into three main sections:

- General parameters:** Includes radio buttons for 'Automatic' (selected) and 'Manual'. There is a checkbox for 'FBK K1/K2 Enable' and a dropdown for 'FBK K1/K2 Reading time'. The 'Muting type' is set to 'Muting L2X/L2P'. There are checkboxes for 'With Enable' and 'Sensor filtering'. The 'Max sensors time gap' is set to 4 s. A diagram shows a light curtain with a 'Gap' between two sensors. 'Filtering Time' is 500 ms, 'End Muting Time' is 4.0 s, and 'Blind Time' is 500 ms. There is a 'Muting Timeout: 30 s' slider. 'Sensor 2 Position' is set to 'Blue Connector' with 'S1 - S2 Blue'. There are checkboxes for 'External lamp control' and 'Minimum sensors time gap (150 ms)'.
- Partial Muting:** Includes a checked checkbox for 'Partial Muting Enable'. There are radio buttons for 'With Enable' (selected) and 'With Disable'. The 'Number of Rays' is set to 6.
- OVERRIDE:** Includes a checked checkbox for 'Override enabled' and an unchecked checkbox for 'With Occupied Sensors'. The 'Timeout' is set to 15 min and the 'Override Mode' is set to 'Hold-to-run-Control'.

After you have properly configured the safety light curtain, you can save all configuration settings (icon





).

## Configuration Check

### Configuration Validation and Loading

To check the correctness of the configuration of the safety light curtain:

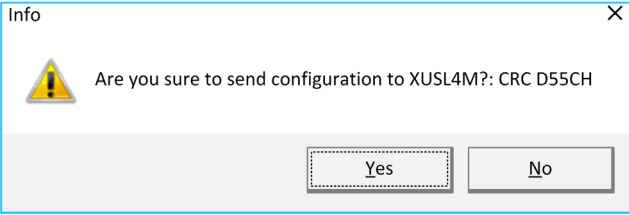
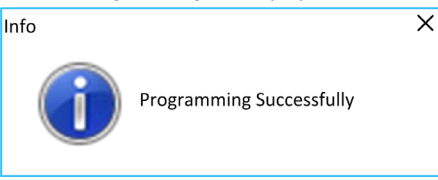
Step	Action
1	Click the validation procedure icon  .
2	Send the configuration to the safety light curtain by clicking  icon and click <b>Yes</b> button to confirm. 
3	The following message is displayed at the end of a successful programming: 

The proper functioning of the safety light curtain system assumes that the configuration has been performed in compliance with the regulations stated in Conformity/Approvals ([see page 118](#)) and with what is defined in sections Meeting Full Compliance ([see page 11](#)) as well as in Muting Type Description ([see page 35](#)).

## WARNING

### UNINTENDED EQUIPMENT OPERATION

Do not operate the system if the safety light curtain has not been configured following the requirements above.

**Failure to follow these instructions can result in death, serious injury, or equipment damage.**

## Report Configuration

### Print Report Configuration



Thanks to the Report Printing feature (icon  ) you can make a report of the main parameters set by the operator during configuration.

**NOTE:** This function allows immediate verification of the configuration settings.

Report example:

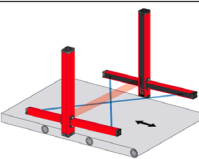
<b>Print Report</b>		
SoMute Configurator Ver.:1.1.1		
<b>Company: Entreprise</b>		
• User: Name		
• Project: Project		
Date: 12/06/2018	CRC: D55CH	
<b>General Parameters</b>		
Automatic		
Feedback K1_ K2 disabled		
<b>Muting</b>		
Muting type	Muting L2X/L2P	
Muting Timeout	30 s	
With Enable	NO	
Max sensors time gap	4 s	
Min sensors time gap	NO	
Sensor 2 Position	<a href="#">Blue Connector</a>	
End Muting Time	4.0 s	
Blind Time	500 ms	
Sensor filtering	NO	
External lamp control	NO	
<b>Partial Muting</b>		
Partial Muting Enable	YES	
Number of Rays	1	With Disable
<b>OVERRIDE</b>		
Override Enabled	YES	
Override Mode	Hold-to-run-Contr	
Timeout	15 min	
With Occupied Sensors	NO	
<b>Signature:</b>		

## Errors Log

### Errors Download



Clicking the download icon , the operator can download the errors log file containing error code, microprocessor involved, and error address.

XUSL4MA\* Firmware version 0.0.0: Errors Log ×

Failures Report Micro A	Error Code	Error Address	Failures Report Micro B	Error Code	Error Address
1	107D	1584H	1	107D	1584H
2	35D	2423H	2	35D	03BCH
3	50D	03BCH	3	50D	2423H

Exit Last erase date: 10/16/2017

### Errors Table

Error Code (decimal)	Failure description	Action
0...25	Internal error	Contact the customer support in your country
34 35, 37 40, 47 49, 50	OSSD error	Check connection of pins 3, 4 on the main male receiver connector
32, 33, 36, 38, 39, 41 42, 43, 44 45, 46, 48, 51	OSSD internal error	Contact the customer support in your country
64...73	Main board internal error	Contact the customer support in your country
74, 75	Overcurrent on 24 Vdc	Check max current consumption < 1.6 A
76...85 90	Main board internal error	Contact the customer support in your country
86, 87	STATUS out error	Check connection of pin 12 on the main male receiver connector
88	Overcurrent on external LAMP	Check connection of pin 1 on the receiver LAMP/USB connector
89	See 86, 87, 88	See 86, 87, 88
105, 106	Interfering transmitter detected	Invert the position of the transmitter and receiver Move the interfering transmitter so that it does not illuminate the receiver Shield the beams coming from the interfering transmitter using opaque protections
128	Configuration error	Check connection of pins 6, 11 on the main male receiver connector
129	Initial configuration modified	Check connection of pins 6, 11 on the main male receiver connector
130	See 128, 129	See 128, 129
131, 132	With EDM active, incorrect status on PIN 8	Check connection of pin 8 on the main male receiver connector
133	Stuck EDM contact (closed)	Check K1/K2 external contacts
134	Open EDM contact	Check K1/K2 external contacts
135	See 133, 134	See 133, 134
136	Override configuration error	Check connection of pins 9, 10 on the main male receiver connector
137	Exceeded max number of override requests	Turn off and on the safety light curtain
138	See 137	See 137
139	24 Vdc on STATUS output	Check connection of pin 12 on the main male receiver connector



<b>Error Code (decimal)</b>	<b>Failure description</b>	<b>Action</b>
140	Overcurrent on STATUS output	Check connection of pin 12 on the main male receiver connector
141	See 139, 140	See 139, 140
142	Error on integrated lamp	Contact the customer support in your country
143, 144	Error on external lamp	Check connection of pin 1 on the receiver LAMP/USB connector
146, 147	Muting sensors configuration error	Check muting sensor connections Check position of sensor 2 configured in SoMute software If no error is detected, contact the customer support in your country



## Safety Light Curtain Activation

### Activation

The actual operation and display of the safety light curtain is obtained via two successive commands:

- Disconnect (icon ), the safety light curtain is now operative (disconnection from the configuration mode).
- Monitor safety light curtain status (icon ).

## Monitoring of the Safety Light Curtain Operation

### Monitoring

At this stage, you have a dynamic reading of the safety light curtain operating condition.

In particular, they are highlighted:

- A graphic representation of the safety light curtain, with integrated lamp (if present) color status in real time.
- A graphic representation of the color-coded label in real time; Programming blue led and Communication yellow led on = safety light curtain is programmed and communicating.

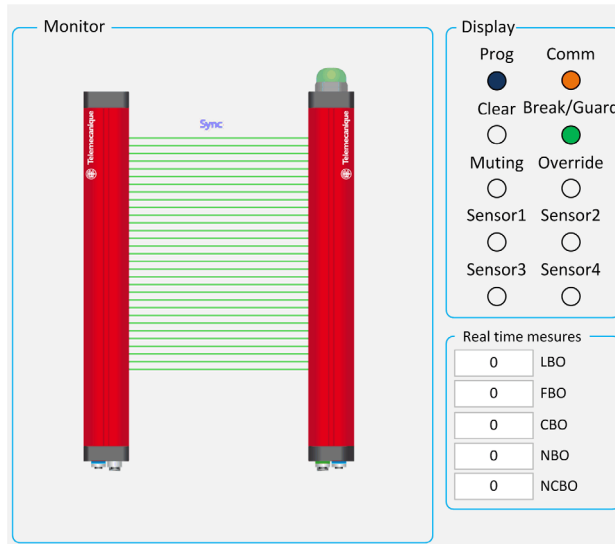

---

# Chapter 12

## SoMute Settings

---

### What Is in This Chapter?

This chapter contains the following sections:

Section	Topic	Page
12.1	General Parameters	<a href="#">156</a>
12.2	Muting Parameters	<a href="#">157</a>

## Section 12.1

### General Parameters

#### Configuration

#### General Functions

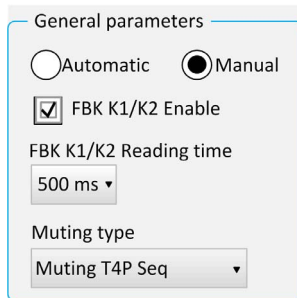

The screenshot shows a configuration window titled "General parameters" with the following settings:

- Operating mode:  Automatic,  Manual
- FBK K1/K2 Enable:
- FBK K1/K2 Reading time: 500 ms (dropdown menu)
- Muting type: Muting T4P Seq (dropdown menu)

The general parameters of the SoMute software are:

- **Automatic/Manual:** This parameter allows you to select the operating mode of the safety light curtain. For more details, refer to how to configure operating modes with XUSL4MA ([see page 28](#)).
- **FBK K1/K2 Enable:** If selected, it is mandatory to read an external EDM signal. For more details, refer to External Device Monitoring (EDM) ([see page 30](#)).
- **FBK K1/K2 Reading Time:** Lets you set a delay in reading the external FBK signal. Possible values: 100...1300 ms (with 100 ms steps). For more details, refer to XUSL4MA External Device Monitoring (EDM) ([see page 31](#)).
- The **Muting type** is selected among the following list:
  - L2X/L2P: Two Crossed Or Parallel Muting Sensors, Unidirectional Mode, Timing Control ([see page 158](#))
  - T2X: Two Cross Muting Sensors, Bidirectional, Timing Control ([see page 160](#))
  - T4P Timing or Concurrent: Four Parallel Muting Sensors, Bidirectional Mode with Timing (or Concurrent) Control ([see page 161](#))
  - T4P Sequential: Four Parallel Muting Sensors, Bidirectional Mode with Sequential Control ([see page 162](#))

---

## Section 12.2

### Muting Parameters

---

#### What Is in This Section?

This section contains the following topics:

Topic	Page
Two Crossed or Parallel Muting Sensors, Unidirectional Mode (L2X/L2P), Timing Control	<a href="#">158</a>
Two Cross Muting Sensors, Bidirectional (T2X), Timing Control	<a href="#">160</a>
Four Parallel Muting Sensors, Bidirectional Mode (T4P) with Timing (or Concurrent) Control	<a href="#">161</a>
Four Parallel Muting Sensors, Bidirectional Mode (T4P) with Sequential Control	<a href="#">162</a>

## Two Crossed or Parallel Muting Sensors, Unidirectional Mode (L2X/L2P), Timing Control

### Description

The activation of the Muting function occurs after the sensors S1 and S2 are interrupted (within a time between 2 s and 5 s decided by the operator). The status of Muting ends after the release of the safety light curtain.

For more details, refer to Two Crossed Or Parallel Muting Sensors, Unidirectional Mode (L2X/L2P), Timing Control (*see page 37*).

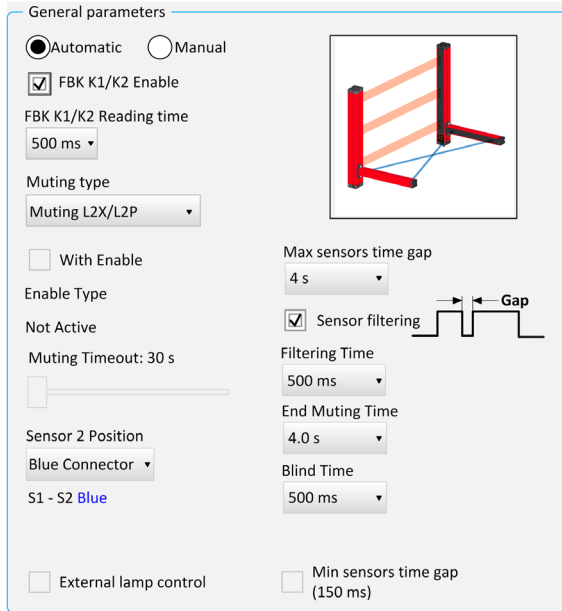

### General Parameters

- **With\_Enable:** If checked, it is possible to read the external signal of "MUT\_ENABLE" (Muting Enable). Otherwise, the Muting function is always enabled. For more details, refer to Muting Enable (*see page 48*).
- **Muting Timeout:** Allows you to set the time, variable from 10 sec to unlimited, within which the Muting cycle must end. When the muting cycle is not yet over and the time-out is elapsed, the muting function is disabled immediately. For more details, refer to L2X/L2P Timing Diagrams (*see page 40*).
- **Max sensors time gap:** You can set the maximum time (2...5 seconds) allowed between the activation of two muting sensors.
- **Sensors filtering / Filtering Time:** For non-homogeneous materials with possible detection holes (like pallets) which might lead to the interruption of the muting, this parameter allows filtering the drop of the sensor signal, leaving then the muting sequence unchanged. This parameter can be set at 500 ms or 1000 ms.
- **Sensor 2 Position:** When using XUSZAML2• or XUSZA•T2X• integrated muting arms or T2X, L2P or L2X muting types with two separate muting sensors (with 2 separate connectors):  
 Sensor 1 connector has to be wired on Sensor1 input (blue connector) and sensor 2 connector must be connected to the RED connector (sensor 3 input).  
 Sensor 1 and sensor 2 can also be both connected to the BLUE connector through XZCRSR (for receiver) and XZCRSE (for transmitter) splitters.  
 In software configuration (XUSL4MA only), the physical position of the connectors must be set in accordance in SoMute software:

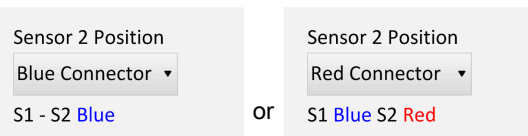

For more details, refer to Wiring (*see page 93*).

- **End Muting Time:** This parameter sets the time (from 2.5 to 6 seconds, with 500 ms steps) allowed between the release of the first sensor and the release of the hazardous zone limited by the safety light curtain. At the end of this time the Muting function ends.

- **Blind Time:** In some cases, after the complete transit of the pallet (muting cycle ending), objects may be prominent and protrude from the load of the pallet, thus leading to interrupt the safety light curtain. To avoid a switching OFF of the OSSD outputs, a **Blind Time** can be set. The **Blind Time** is an extra time allowed after the end of the muting cycle to let the objects pass through the hazardous area limited by the safety light curtain. During the **Blind Time**, the OSSDs remain at the ON state. The **Blind Time** can be set from 250 ms to 1 s (steps 250 ms).
- **Min sensors time gap:** If selected, it allows Muting activation only if the time between activation of sensor 1 and sensor 2 is greater than 150 ms.
- **External lamp control:** If selected, external Muting lamp is compulsory.

## Two Cross Muting Sensors, Bidirectional (T2X), Timing Control

### Description

The activation of the Muting function occurs after the interruption of sensors S1 and S2 (within a time between 2 s and 5 s decided by the operator). As long as both sensors remain interrupted, the Muting function continues. By releasing the first of the two sensors, the Muting function is disabled.

For more details, refer to Two Cross Muting Sensors, Bidirectional (T2X), Timing Control ([see page 41](#)).

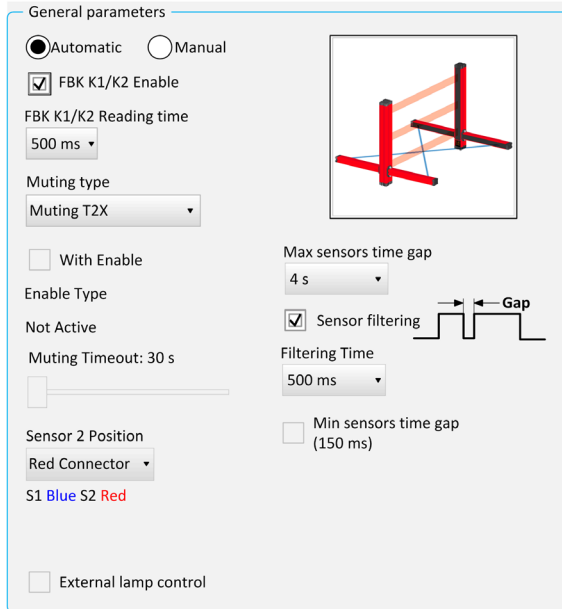

### General Parameters

- **With\_Enable:** If checked, it is possible to read the external signal of "MUT\_ENABLE" (Muting Enable). Otherwise, the Muting function is always enabled. For more details, refer to Muting Enable ([see page 48](#)).
- **Muting Timeout:** Allows you to set the time, variable from 10 sec to unlimited, within which the Muting cycle must end. When the muting cycle is not yet over and the time-out is elapsed, the muting function is disabled immediately. For more details, refer to L2X/L2P Timing Diagrams ([see page 40](#)).
- **Max sensors time gap:** You can set the maximum time (2...5 seconds) allowed between the activation of two muting sensors.
- **Sensors filtering / Filtering Time:** For non-homogeneous materials with possible detection holes (like pallets) which might lead to the interruption of the muting, this parameter allows filtering the drop of the sensor signal, leaving then the muting sequence unchanged. This parameter can be set at 500 ms or 1000 ms.
- **Sensor 2 Position:** When using XUSZAML2• or XUSZA•T2X• integrated muting arms or T2X, L2P or L2X muting types with two separate muting sensors (with 2 separate connectors):  
 Sensor 1 connector has to be wired on Sensor1 input (blue connector) and sensor 2 connector must be connected to the RED connector (sensor 3 input).  
 Sensor 1 and sensor 2 can also be both connected to the BLUE connector through XZCRSR (for receiver) and XZCRSE (for transmitter) splitters.  
 In software configuration (XUSL4MA only), the physical position of the connectors must be set in accordance in SoMute software:

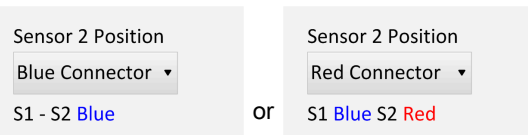

For more details, refer to Wiring ([see page 93](#)).

- **Min sensors time gap:** If selected, it allows Muting activation only if the time between activation of sensor 1 and sensor 2 is greater than 150 ms.
- **External lamp control:** If selected, external Muting lamp is compulsory.



## Four Parallel Muting Sensors, Bidirectional Mode (T4P) with Timing (or Concurrent) Control

### Description

The activation of the Muting function occurs after the sensors S1 and S2 are interrupted (within a time between 2 s and 5 s decided by the operator) or S4 and S3 with material moving in the opposite direction. The Muting state ends after the release of the safety light curtain, or of the S3 sensor (or S2 with material moving in the opposite direction).

**NOTE:** The Muting cycle can start if all sensors and the safety light curtain are released.

For more details, refer to Four Parallel Muting Sensors, Bidirectional Mode (T4P) ([see page 45](#)).

General parameters

Automatic  Manual

FBK K1/K2 Enable

FBK K1/K2 Reading time  
500 ms

Muting type  
Muting T4P Con

With Enable

Enable Type

Not Active

Muting Timeout: 30 s

Sensor 2 Position  
Blue Connector

Muting Ending  
CURTAIN

External lamp control

Max sensors time gap  
4 s

Sensor filtering

Filtering Time  
500 ms

Direction  
BIDIR

Blind Time  
500 ms

Min sensors time gap (150 ms)

### General Parameters

- **With\_Enable:** If checked, it is possible to read the external signal of "MUT\_ENABLE" (Muting Enable). Otherwise, the Muting function is always enabled. For more details, refer to Muting Enable ([see page 48](#)).
- **Muting Timeout:** Allows you to set the time, variable from 10 sec to unlimited, within which the Muting cycle must end. When the muting cycle is not yet over and the time-out is elapsed, the muting function is disabled immediately.
- **Max sensors time gap:** You can set the maximum time (2...5 seconds) allowed between the activation of two muting sensors.
- **Sensors filtering / Filtering Time:** For non-homogeneous materials with possible detection holes (like pallets) which might lead to the interruption of the muting, this parameter allows filtering the drop of the sensor signal, leaving then the muting sequence unchanged. This parameter can be set at 500 ms or 1000 ms.
- **Direction:** You can set the order of obstruction of the Muting sensors. If BIDIR is selected, the muting can take place in both direction from S1 & S2 to S3 & S4 and reverse order. If UP is selected, the muting is restricted to a one-way path S1 & S2 to S3 & S4 and with DOWN to a one-way path S4 & S3 to S2 & S1.
- **Muting ending:** It can be of two types CURTAIN or SENSOR. By selecting CURTAIN, muting closes at the release of the protected area limited by the safety light curtain while with SENSOR ending occurs after the release of the last but one sensor (S3 or S2 depending on the direction).
- **Blind Time:** Only available by selecting **Muting ending** = CURTAIN. In some cases, after the complete transit of the pallet (muting cycle ending), objects may be prominent and protrude from the load of the pallet, thus leading to interrupt the safety light curtain. To avoid a switching OFF of the OSSD outputs, a **Blind Time** can be set. The **Blind Time** is an extra time allowed after the end of the muting cycle to let the objects pass through the hazardous area limited by the safety light curtain. During the **Blind Time**, the OSSDs remain at the ON state. The **Blind Time** can be set from 250 ms to 1 s (steps 250 ms).
- **Min sensors time gap:** Only available by selecting **Muting ending** = CURTAIN. If selected, it allows Muting activation only if the time between activation of sensor 1 and sensor 2 (or sensor 4 and sensor 3) is greater than 150 ms.
- **External lamp control:** If selected, external Muting lamp is compulsory.

## Four Parallel Muting Sensors, Bidirectional Mode (T4P) with Sequential Control

### Description

The activation of the Muting function occurs after the sequential interruption of sensors S1 and S2 (or S4 and S3 with material moving in the opposite direction) without time limitations. The Muting state ends after the release of the safety light curtain, or of the S3 sensor (or S2 with material moving in the opposite direction).

For more details, refer to Four Parallel Muting Sensors, Bidirectional Mode (T4P) ([see page 45](#)).

General parameters

Automatic  Manual

FBK K1/K2 Enable

FBK K1/K2 Reading time  
500 ms

Muting type  
Muting T4P Seq

With Enable

Enable Type  
Not Active

Muting Timeout: 30 s

Sensor 2 Position  
Blue Connector

Muting ending  
CURTAIN

External lamp control

Sensor filtering

Filtering Time  
500 ms

Direction  
BIDIR

Blind Time  
500 ms

### General Parameters

- **With\_Enable:** If checked, it is possible to read the external signal of "MUT\_ENABLE" (Muting Enable). Otherwise, the Muting function is always enabled. For more details, refer to Muting Enable ([see page 48](#)).
- **Muting Timeout:** Allows you to set the time, variable from 10 sec to unlimited, within which the Muting cycle must end. When the muting cycle is not yet over and the time-out is elapsed, the muting function is disabled immediately.
- **Sensors filtering / Filtering Time:** For non-homogeneous materials with possible detection holes (like pallets) which might lead to the interruption of the muting, this parameter allows filtering the drop of the sensor signal, leaving then the muting sequence unchanged. This parameter can be set at 500 ms or 1000 ms.
- **Direction:** You can set the order of obstruction of the Muting sensors. If BIDIR is selected, the muting can take place in both direction from S1 & S2 to S3 & S4 and reverse order. If UP is selected, the muting is restricted to a one-way path S1 & S2 to S3 & S4 and with DOWN to a one-way path S4 & S3 to S2 & S1.
- **Muting ending:** It can be of two types CURTAIN or SENSOR. By selecting CURTAIN, muting closes at the release of the protected area limited by the safety light curtain while with SENSOR ending occurs after the release of the last but one sensor (S3 or S2 depending on the direction).
- **Blind Time:** Only available by selecting **Muting ending** = CURTAIN. In some cases, after the complete transit of the pallet (muting cycle ending), objects may be prominent and protrude from the load of the pallet, thus leading to interrupt the safety light curtain. To avoid a switching OFF of the OSSD outputs, a **Blind Time** can be set. The **Blind Time** is an extra time allowed after the end of the muting cycle to let the objects pass through the hazardous area limited by the safety light curtain. During the **Blind Time**, the OSSDs remain at the ON state. The **Blind Time** can be set from 250 ms to 1 s (steps 250 ms).
- **External lamp control:** If selected, external Muting lamp is compulsory.

---

# Appendices

---





---

# Appendix A

## Checkout and Test Procedures

---

### What Is in This Chapter?

This chapter contains the following topics:

Topic	Page
Checkout Procedure	<a href="#">166</a>
Test Procedure	<a href="#">168</a>

## Checkout Procedure

### Procedure

A qualified personnel must perform the checkout procedure given in the table during the initial installation and at least once every 3 months thereafter or more frequently depending on machine usage and company guidelines.

Make a copy of the checkout procedure form, use the copy as the checkout log, and store it with the machine records. Be careful when you work around hazardous voltages present during this procedure.

**Machine Identification:**

**Date:**

Item		Condition	Comments
1	Check that the guarded machine is compatible with the type of machine that is used with the XUSL4M system. Refer to Meeting Full Compliance ( <a href="#">see page 11</a> ) and Selection and Orientation of Muting Sensors ( <a href="#">see page 35</a> ).	Pass	
		Fail	
2	Check that the mounting distance of the XUSL4M system is greater than or equal to minimum safe distance from the hazardous zone Refer to Safe mounting distance ( <a href="#">see page 63</a> ).	Pass	
		Fail	
3	Determine that the access to the hazardous zone which is not protected by an XUSL4M system is guarded by other means, such as gates, fencing, wire, or other approved methods. Verify that additional guarding devices are installed and operating correctly.	Pass	
		Fail	
4	Ensure that the operator does not stand between the XUSL4M system detection zone and the machine hazardous zone. Verify that the restart and override XUSL4M commands are accessible from a position outside and within view of the hazardous machine area only.	Pass	
		Fail	
5	Check that the XUSL4M is powered by a safety extra low voltage (SELV) or a protected extra low voltage (PELV). Refer to Wiring ( <a href="#">see page 93</a> ).	Pass	
		Fail	
6	Check that the external contactors conform the External Device Monitoring (EDM) General Description ( <a href="#">see page 30</a> ) (mirror contacts or force-guided contacts).	Pass	
		Fail	
7	Make sure that there is no reflective surfaces that might affect the proper operation of the XUSL4M. Refer to Reflective Surface Interference ( <a href="#">see page 72</a> ).	Pass	
		Fail	
8	Make sure that they are no interfering light sources that might affect the proper operation of the XUSL4M. Refer to Multiple Systems ( <a href="#">see page 76</a> ).	Pass	
		Fail	
9	When used, make sure that the MUTING/OVERRIDE signal lamp is correctly installed in a location visible by the operator.	Pass	
		Fail	
10	Inspect the electrical connections between the control system of the guarded machine and the XUSL4M system. Verify that they are connected correctly to the machine so that a stop signal from the XUSL4M system results in an immediate halt of the machine cycle.	Pass	
		Fail	

Item		Condition		Comments
11	If the EDM monitoring feature is not used, proceed to step 12. To test the EDM feature: <ul style="list-style-type: none"><li>● Verify that the feature has been correctly wired.</li><li>● Turn on the machine power.</li><li>● Cycle the machine.</li><li>● Disconnect the K1/K2 EDM feedback loop wire to test the EDM monitoring feature. Interrupt the detection zone, and the system should enter (and stay at) the start/restart state (CLR yellow LED lit on the receiver) even if a restart command is operated.</li></ul>		Pass	
			Fail	
12	Record the test results in the machine log. Then perform the Test procedure ( <a href="#">see page 168</a> ).		Results recorded	

**Comments:**

**Technician Signature:**

## Test Procedure

### Procedure

A qualified personnel must perform the test procedure in the given table during initial XUSL4M safety light curtain system installation, according to the regular inspection program of the employer after any maintenance, adjustment, or modification of the XUSL4M safety light curtain system or the guarded machine.

 <b>WARNING</b>
<p><b>UNINTENDED EQUIPMENT OPERATION</b></p> <p>The test frequency (e.g daily testing) must be carried out depending on the risk analysis. This testing ensures that the safety light curtain, safety system, and the machine control system work together to stop the machine. If the test procedures are not followed, it could result in serious injury to personnel. To test the XUSL4M safety light curtains, use the proper-size test rod.</p> <p><b>Failure to follow these instructions can result in death, serious injury, or equipment damage.</b></p>

Make a copy of the checkout procedure form, use the copy as the checkout log, and store it with the machine records. Be careful when you work around hazardous voltages present during this procedure.

Item	Condition	Pass	Fail	Comments
1	Switch off the machine to be guarded and connect power to the XUSL4M system.	Pass	Fail	
2	Visually inspect the machine to ensure that the hazardous zone is accessible only through the XUSL4M detecting zone. If not, additional guarding, including mechanical barriers, may be required. Verify that the additional guarding devices and barriers are installed and operating properly.	Pass	Fail	
3	Check that the mounting distance of the XUSL4M system is greater than or equal to the calculated minimum safe distance from the hazardous zone. For more information, refer to Safe mounting distance ( <a href="#">see page 63</a> ). Ensure that the operator does stand between the XUSL4M detection zone and the hazardous zone.	Pass	Fail	
4	Check for signs of external damage to the XUSL4M system, the machine, and, the electrical cables and wiring. If there is any damage, lock off the machine and report the damage to the supervisor.	Pass	Fail	
5	Interrupt the XUSL4M system detection zone with the applicable test object (test rod). Move the test object inside the perimeter (along the top, sides, and bottom) of the detection zone and, up and down through the center. Verify that while the test rod object is in the perimeter, the red LED on the receiver is always ON. Refer to the Test Rod Procedure ( <a href="#">see page 74</a> ). In manual Start/Restart mode, press and release the <b>Start</b> button before proceeding to step 6.	Pass	Fail	
6	Start the machine and then interrupt the detection zone with the test object which should stop the machine immediately. Do not insert the test object into the hazardous parts of the machine. Interrupt the detection zone with the test object when the machine is at rest. Ensure that the machine does not start with the test object in the detection zone.	Pass	Fail	
7	Verify that the braking system is working properly. If the machine does not stop fast enough, adjust the braking system or increase the distance from the detection zone to the hazardous zone.	Pass	Fail	



Item		Condition		Comments
8	Check the correct functioning of the required muting sequence.		Pass	
			Fail	
9	If the safety devices or the machine fail any of these tests, do not run the machine. Tag or lock out the machine immediately to prevent its use and notify the supervisor.			

**NOTE:** A periodic cleaning of the front face protection surfaces (polycarbonate optical window) of the devices is recommended. Cleaning must be carried out with a soft damp cloth only. In dusty environments, after cleaning the front face, it is advisable to spray it with an anti-static product

 <b>WARNING</b>
<p><b>UNINTENDED EQUIPMENT OPERATION</b></p> <ul style="list-style-type: none"> <li>● Do not use abrasive, corrosive, solvents, or alcohol that may damage the polycarbonate front surfaces.</li> <li>● Do not use wiped or wool cloth to avoid electrostatically loading the polycarbonate front surfaces.</li> </ul> <p><b>Failure to follow these instructions can result in death, serious injury, or equipment damage.</b></p>

Even a very fine scratch on polycarbonate front surfaces can increase the width of the beam of the safety light curtain, thus compromising the effectiveness of detection in the presence of eventual reflective lateral surfaces. It is therefore required to pay particular attention during the cleaning steps of the safety curtain front surface, particularly in environments where abrasive powders are present (for example cement plants, and so on).

**Comments:**





## A

### ANSI

American National Standards Institute. The administrator and coordinator of the U.S. private sector standardization system.

## C

### Category (Cat.)

Describe the safety-related parts of control systems performance in relation to their ability to resist to failures and resulting behavior in case of failure. Five categories are defined depending on design architectures.

### Control-reliable

The device, system, or interface shall be designed, constructed, and installed such that a single component failure within the device, interface, or system shall not prevent normal stopping action from taking place, but shall prevent a successive machine cycle (ANSI B11.191).

## D

### Detection zone

The zone within which a specified test piece is detected by the XUSL4M safety light curtain system.

### Diagnostic coverage (DC)

Efficiency measurement of self-tests conducted on a function. This is determined as the ratio of the rate of dangerous detected failures (per hour) and the rate of dangerous failures per hour.

## E

### EDM/MPCE (External Device Monitoring/Machine Primary Control Element Monitoring)

A means by which the safety light curtain monitors the state of external control devices.

### ESPE

Electro-sensitive protective equipment.

## M

### Mean time to dangerous failures (MTTFd)

Expectation of the mean time to dangerous failure.

## O

### Off state

The state in which the output circuit is interrupted (open) and does not allow current to flow.

### On state

The state in which the output circuit is complete (closed) and allows the flow of current.

### OSHA

Occupational Safety and Health Administration. This is a U.S. government agency.

### Output Safety Switching Device (OSSD)

The component of the safety light curtain connected to the machine control system which, when the safety light curtain detection zone is interrupted, responds by going to Off state. This is also known as a safety output.

## P

### **Performance level (PL)**

Ability of safety-related parts of control systems (SRP/CS) to perform a safety function in order to achieve the required risk reduction.

### **Probability of Dangerous Failure per Hour**

(PFH<sub>D</sub>) Average probability of dangerous failure per hour for high demand mode of operation.

## R

### **Resolution or Minimum Object Sensitivity (MOS)**

The diameter (in millimeters) of the minimum-sized object that actuates the safety light curtain.

### **Response time**

Time taken by the protective device to transmit the signal to stop the main engine.

## S

### **Safety Integrated Level (SIL)**

The failure mode evaluation based on the risk assessment in accordance with EN/IEC 61508. Estimation of the required SIL is performed for each safety-related control function (SRCF) and represent the levels that the control-command must respect according to the known risk factors associated with the installation. Level 3 is the highest and Level 1 the lowest level.

### **Safety Integrated Level Claim Limit (SILCL)**

Maximum SIL that can be claimed for safety function of any subsystem.

## T

### **Test Rod**

An opaque cylindrical object used to verify the detection capability of the XUSL2E/XUSL4E system.